

PHOENIX – ARMATURENWERKE
Germany



Operation instructions for Globe valves with actuators

BA 112/133 AV-ST
Edition 2024-04_02

Globe Valves



Globe Valves for Stationary Tanks /
Angle type 309 based on type 355

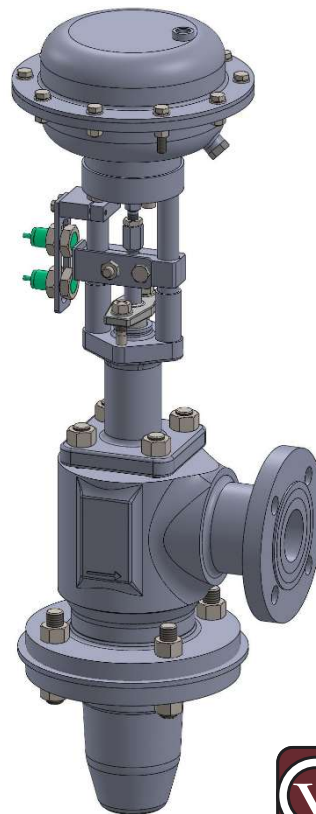

Edition		00		01		02			
Date	Name	08/23	Wo	02/24	Wo	04/24	Wo		
Edition									
Date	Name								



Operation instructions - Globe valves with actuators

Declaration of conformity acc. to Directive 2014/68/EU

and manufacturer's declaration according to Directive 2006/42/EC

The manufacturer	PHOENIX Armaturenwerke GmbH 34471 Volkmarsen, Germany
declares that the valves	Trade Name / Brand PHÖNIX: - Globe valves with stuffing box seal / with bellows seal and secondary stuffing box seal - Globe Valves for Stationary Tanks /Angle type types 350, 352, 353, 355HS, 309 (355), EC.16/17, 390, 393, 430, 919, 925, 935, 941 • with pneumatic / electric / hydraulic • with free spindle for posterior actuator assembling
<ol style="list-style-type: none">1. are pressure bearing equipment within the meaning of the Pressure Equipment Directive 2014/68/EU and in conformity with the requirements of this directive,2. can only be used and operated under observance of the attached operation manual N° BA112-133-AV-ST.	

Related standards:

DIN EN 16668	Requirements and testing for metallic valves as pressure accessories Direction for pressure bearing body components <small>Body- and Bonnet Material with Inspection Certificate 3.1 to EN 10204</small>
DIN EN 19 DIN-EN-12100	Marking of metallic valves General design principles, risk assessment and risk reduction methods

Description of type and technical features:

PHOENIX-type datasheets <350, 352, 353, 355HS, 309(355), EC.16/17, 390, 393, 430, 919, 925, 935, 941>

NOTE: This manufacturer declaration is valid for all variants of types mentioned in the PHOENIX catalogue

Applied procedure for the rating of the conformity:

to Annex III of the Pressure Equipment Directive 2014/68/EU Module „H“

Name of the notified body:

Identification N° of the notified body:

LRQA Deutschland GmbH	0525
------------------------------	-------------

According to the guidelines for the application of the Council's general direction 2014/34/EU of 26.02.2014 for adapting legal regulations valid in the single member countries and dealing with apparatuses and safety systems and their application in areas endangered by explosion, globe valves do not have an integrated potential source of sparks as revealed by the danger of releasing sparks analysis. Due to this, globe valves are not subject to the guideline mentioned above.

Volkmarsen, 29.04.2024

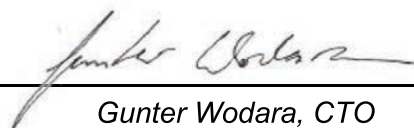
Gunter Wodara, CTO

Operation instructions - Globe valves with actuators

0 Introduction

This instruction shall support the user for installation, operation and maintenance of globe valve types **350, 352, 353, 355HS, 309(355), EC.16/17, 390, 393, 430, 919, 925, 935, 941**.

 Attention	<p>The non-observance of the following attention and warning notes might cause dangers with the consequence that the manufacturer's guarantee becomes void.</p> <p>For questions in this regard contact the manufacturer, addresses see section 8.</p>
---	--

1. Defined use

After their installation in a piping system (either between flanges or by welding) and the connection of the actuator the use of the globe valve **types 350, 352, 353, 355HS, 309(355) EC.16/17, 390, 393, 430, 919, 925, 935, 941** is exclusively defined as to stop or convey the flow of media within the admitted pressure and temperature limits by manual operation. The safety instructions of section 2 <safety instructions> shall be observed. The use of these valves for media with solid matters, especially with wearing particles is not re-commended.

The design document <Pressure-Temperature-Tables TDB3/1 to 3/5> (see section 8.1 <Information>) shows the admitted pressure-temperature-range for these globe valves.

It is assumed that the safety instructions of section 2 <safety instructions> shall be observed.

2. Safety instructions

2.1 General safety instructions



Valves are subject to the same safety impositions which are valid for the piping system where the valves shall be installed as well as for the control system where the actuator is connected to. The present instruction mentions only such kind of safety notes which must additionally be considered for valves.

Additional safety notes are given in the instructions of the actuator components.

2.2 Safety instructions for the user

It is not within the responsibility of the manufacturer and must be safeguarded by the user of the globe valve that:







⇒ the valve is only used as required by the "defined use" as described in section 1

 Danger to life	<p>Valves whose admitted pressure-temperature range (= "Rating") is not sufficient for the operating conditions shall not be used. For materials or pressures or temperatures not indicated in the a.m. <Pressure-Temperature-Tables TDB 3/1 to 3/5> a release note from the manufacturer is mandatory.</p> <p>The disregard of this ordinance can provoke danger to life and cause damages in the piping system.</p>
 Note	<p><i>Globe valves are not suitable for an operation in intermediate position.</i></p> <p>A globe valve shall only be used with its final positions totally open or totally closed.</p> <p>If the valve should be used with in an intermediate position and/or for a throttling/regulating target, valves with a rigid disc shall be installed.</p>
 Danger	<p><i>Protection against wrong use of the globe valve:</i></p> <p>It must be absolutely assured that the selected materials of the wetted parts of the globe valve are suitable for the handled media. The manufacturer is not responsible for damages of the globe valve caused by corrosive agents.</p> <p>The disregard of this ordinance can provoke danger for the user and cause damages in the piping system.</p>

Operation instructions - Globe valves with actuators

- ⇒ An actuator unit which is fitted later on to the valve shall be adapted to this valve. In the closed position the final stop shall be realized in the seat of the valve,
- ⇒ The globe valve and the control system will be installed workmanlike in the piping system, especially such types of valves which are fitted into the piping system by welding. The wall thickness of the valve body shall be calculated in such a way that an additional load F_z within the usual order of magnitude ($F_z = \pi/4 \cdot DN^2 \cdot PS$ or PN) is considered for such a workmanlike mounted piping system.
($PS = \text{max. admitted design pressure at ambient temperature}$),
- ⇒ the valve shall be fitted workmanlike with these systems,
- ⇒ inside this piping system the usual flow rates in continuous operation shall not be exceeded and exceptional operating conditions such as vibrations, water hammers, cavitation and higher percentages of solid matters in the media – especially wearing ones – had been cleared with the manufacturer,
- ⇒ globe valves used at operating temperatures $>+50^\circ\text{C}$ or $<-20^\circ\text{C}$, are protected against contact as it is intended for the pertinent piping system,
- ⇒ Only qualified staff is used for the operation and maintenance of equipment for pressure bearing piping systems.

2.3 Special risks

 Danger to life	Valves with stuffing box seal The operating stem is sealed by a stuffing box. Before a loosening of the nuts on the gland follower the piping system shall be completely depressurized to avoid the leakage of the media throughout the stuffing box.
 Danger to life	Before the disassembling of the valve out of the piping system and/or before the loosening of the bolts and nuts of the bonnet the system shall be completely depressurized to avoid an uncontrollable fugitive emission of the media. It must be assured that the valve is completely open to enable that the pressure can escape on both sides of the valve.
 Danger	<i>Globe valves which are used as final shut-off valve:</i> For normal operation, especially with gaseous, hot and/or dangerous media a blind flange or a cover plate shall be fitted on the free outlet or adequately secured against unauthorized operation acc. to the directives of EN 292 – Part 2.
 Danger	<i>Globe valves which are not slowly operated in the starting up phase at service temperatures of $>250^\circ\text{C}$:</i> Leakages might occur. See also section 6.1 <Starting-up phase>
 Danger	Whenever a globe valve which is used as final valve shall be opened under pressure load this must be performed with extraordinary care and in such a manner to assure that the out-spurring media cannot provoke damages.
 Danger	When a valve shall be disassembled from the piping system there exists the risk that the media can flow out of the piping or the valve. In case of liquids which are harmful for the health or dangerous the piping system shall be completely drained before the valve can be removed from the system. Caution of residues coming out off or remaining in dead holes of the valve or the piping system itself.

Operation instructions - Globe valves with actuators

2.4 Marking of the globe valve

Each globe valve is normally marked as follows:

For	Marking	Note
CE-Mark	CE	Corresponding to PED 2014/68/EU valves shall be marked with the CE-mark only for sizes DN 32 and more
CE-Ident N°	0525	Nominated body to EU Directive = LRQA Deutschland GmbH Register
Brand	PHÖNIX	Manufacturer PHOENIX Armaturenwerke GmbH
Manufacturer-N°	e.g.:98898/02	The first figures before the strike are the factory number, the last figures after the strike = item n° e.g. /02 = item 2 of the order
Date of manufacture	e.g.: 05/02	The first figures before the strike indicate the month of manufacture (05 = May), the figures after the strike = year of manufacture, e.g. (02 = 2002)
Valve type	Type (and numerical value)	e.g. Type 390, see Data-sheet Phoenix
Body material	e.g.: 1.0619.01	N° of material standard to DIN EN 10027, Part 2
Size	DN or NPS (and numerical value)	Numerical value in mm, e.g. DN 200 or NPS 8
Design pressure	PS or PN (and numerical value)	Numerical value in [bar] at 20°C, e.g. PS 40
	ANSI and Class (numerical value)	e.g. ANSI 300
max, pressure for the closing disc	Dp and numerical value	Numerical value in [bar] at operating pressure e.g. dp = 12 (please see also valve info tag plate)
Heat-/ Melt N°	e.g.: 25652 or GHW	Heat-/Melt N° of the foundry

In addition the actuated valves are marked with a valve information plate

3. Transport and Storage

Globe valves shall be carefully treated, transported and stored:

- ⇒ The valve shall be stored with its protecting packing and/or with its protecting caps on the inlet and outlet. Valves with a weight of more than 10 kos shall be stored on pallets (or similar) and be transported in such a state (even on the transport to the installation point).







 Attention	<p><i>To protect the valve against damages:</i> Ropes and belts shall only be fixed on the body/bonnet but never on the actuator!</p>
---	--

- ⇒ Before its installation the valve shall be normally stored in closed area and be protected against detrimental influences such as dirt and humidity.
- ⇒ In particular the handwheel and the end orifices of the globe valves for the connection with the piping system shall not be damaged neither by mechanical nor other influences.
- ⇒ Globe valves will be supplied with disc in closed position and shall be stored in this state.

4. Installation into the piping system



4.1 General

For the installation of valves into a system the same instructions are valid as for the connection of pipes among themselves and similar piping components. When in a plant the piping and other equipment are isolated, this must also be applied to the built-in globe valves. In addition, the following instructions are valid for globe valves. For the transport to the installation place please mind the information given in section 3 of this manual.

 Danger to life	<p>If globe valves are installed in insulated piping systems, or in the area of other isolated equipment, so they must also be isolate. In absence of insulation, globe valves can be damaged. In serious cases, the pressurized parts could be damaged.</p>
 Note	<p>Globe valves in horizontal pipes should be installed - if possible – with vertical oriented stem (deviations up to 90° from the vertical line are admitted). Other installation positions in horizontal pipes shall be agreed with the manufacturer.</p>
 Attention	<p><i>To avoid damages of globe valves with weld ends:</i> During the welding of the valves into the piping system the weld procedure shall be performed in such a way that the applied heat energy is limited, and distortions of the valve body are avoided. Therefore, larger sizes shall be welded in alternating procedures once from one side and then from the other to avoid restraints in the valve's body. During the weld procedure the globe valve shall be brought and kept in the open position until the weld conjunction is cooled down to <100°C.</p>
 Danger to life	<p>In case of a posterior installation of an actuator unit the interface adaptation, the nominal moment, the sense of the rotation and the switch-off in the final positions "OPEN" and "CLOSED" must be adapted to the globe valve. Disregard of this imposition can provoke danger for the user and damages in the piping system.</p>
 Danger	<p><i>Actuators supplied with the valves are designed for the service conditions indicated in the order and are adjusted to the intended functions.</i> The setting is adapted to the two final positions of the valve and shall not be modified without the approval of the manufacturer.</p>
 Danger	<p><i>For valves with electric actuator only:</i> It must be assured that the actuator will deenergized in both final positions by the signal of the torque switch and additionally path dependent in the open position. In case that the deenergizing with the signal of the torque switch is performed in an intermediate position this signal shall be used for a failure indication. The failure must be eliminated as quick as possible, see section 7 <Trouble shooting> <i>Supplementary information: see instructions of the electric actuator.</i></p>
 Note	<p>When change-over valves will be insulated after their installation it must be assured that the gland follower and the actuator are well accessible.</p>

Operation instructions - Globe valves with actuators

As far as actuator units are concerned:

 Danger	<i>Actuators are neither “stepboards nor ladders”!</i> Actuators shall not be charged with heavy loads; this can damage or distract both the actuator and/or the globe valve.
 Danger	<i>Actuators whose weight is higher than that one of the valve:</i> Such actuators must be supported when they cause a bending load onto the valve due to their size and/or installation positions.

4.2 Working steps

- ⇒ Transport the globe valve in its protecting packing to the installation site and unpack the valve just before its immediate fitting into the system to ensure that the valve is protected against each kind of contamination.
- ⇒ Inspect the valve and the actuator on possible transport damages. Damaged valves shall not be installed.
- ⇒ Make sure that only globe valves will be installed whose pressure rating, type and dimensions of connections correspond to the operating conditions. In this regard also see related marking of the globe valve.

 Danger to life	Globe valves whose admitted pressure-/temperature rating is not sufficient for the operating conditions shall not be installed. This admitted range results in the marking and/or in the design document <Pressure-Temperature-Tables TDB3/1 to 3/5> see also section 1 <Defined use>. Disregard of this precautionary measure can provoke danger to life for the user and damages in the piping system.
--	---

- ⇒ The connections of the piping system shall be in strict alignment with the end connections of the globe valve and shall have plane-parallel ends.
- ⇒ Before the installation the valve and the corresponding pipe shall be carefully cleaned from dirt and contaminations, especially hard foreign particles shall be removed.
- ⇒ The flow direction of globe valve is marked by an arrow. For special applications and information regarding “equilibrating disc” see section 8 < Information>

 Danger to life	Globe valves shall not be installed against the marked flow direction. Disregard of this precautionary measure can provoke danger to life for the user and damages in the piping system.
--	--

- ⇒ Introducing the valve (and the flange gasket) into an existing piping system e.g. in case of replacement, the distance between the pipe ends must be dimensioned in such a way that the sealing surfaces of the flanges and the gaskets, too, will not be damaged.

However, the gap shall not be larger than necessary to avoid additional loads onto the piping system during the installation.

For globe valves with weld ends only:

- ⇒ The weld ends of the valve shall be in true alignment and shall have parallel faces and must be of identical type and materials as the pipes – see type plate of the valve. Opposite weld ends must fit to each other as far as diameters and weld joints are concerned.

Operation instructions - Globe valves with actuators

- ⇒ Make sure by workmanlike welding that neither worth mentioning tensions will be produced in this piping section or on the valve nor that the globe valve body might get distorted due to unilateral heat introduction during the weld procedure. Only temperatures of <math><300^{\circ}\text{C}</math>, measured on the body wall, are admitted.
- ⇒ The welding must be performed workmanlike in such a way that the weld seam has all round about a uniform temperature. Globe valves >DN 300 shall be welded in alternation on their opposite sides.
- ⇒ Weld cables shall not be fixed on the valve itself but exclusively on the piping.

 Attention	Disregard of these impositions can provoke distortion of the valve body. A permanent distortion in the seat area of the valve can signify that the valve becomes unserviceable.
---	--

- ⇒ For the connection of the actuator unit with the control system the relevant instructions are valid.
- ⇒ After the installation but before the commissioning a functional test with the signals of the control system shall be performed. According to the control commands the valve must go into the correct position. Follow the control instructions close and open correctly. Perceptible functional failures shall be repaired before the commissioning of the valve. See also section 7 <Trouble shooting>.

 Danger	Wrongly performed control commands might provoke danger for the user and damages in the piping system.
--	---

5. Pressure test of the piping section.

For the pressure test of globe valves the same instructions are valid as imposed for the piping system. In addition the following shall be considered:

- ⇒ Newly installed pipe system shall be carefully cleansed to flush off all foreign particles.
- ⇒ The test pressure "PT" of an **opened valve** shall **not exceed the value 1,5x PN/PS** by virtue of the marking of the valve.
- ⇒ The test pressure "PT" of a **closed valve** shall **not exceed the value 1,1x max. admitted Dp** by virtue of the marking on the valve info plate (*see section 2.4. <Marking of the globe valve with actuator>*).

6. Starting up/commissioning, normal operation and maintenance.

6.1 Starting up/ Commissioning

When a **globe valve is installed in closed position or as final shut-off device**, during the "starting up phase" of a piping section it must be assured at temperatures of >100°C – especially when globe valves of >DN 300 are involved - that the handled medium will be slowly fed-in. Otherwise, the valve's body gets distorted and the valve will leak.

6.2 Normal operation and maintenance

The unit globe valve/actuator shall be operated with the signals of the control system. An actuator which is supplied ex work together with the globe valve is exactly setted and shall not be misadjusted by third parties.

For the manual override (if equipped) normal hand force is sufficient for the operation of the hand-wheel.

Operation instructions - Globe valves with actuators

The use of **extension rods, levers and similar items to increase the operation moment** is not admitted.

Regular maintenance work is not required for globe valves, however, during the inspection of the piping section no leakage shall appear neither on the flanged and/or screwed connections nor on the stuffing box. In case of leakages and repairs please see section 2 – <Safety instructions> and section 7 <Failures>

 Note	<p><i>Globe valves are not suitable for an operation in intermediate position.</i></p> <p>Globe valves shall only be used in their final position, i.e. either completely opened or closed.</p> <p>When an intermediate/throttling position is required the valve shall be equipped with a rigid regulating disc, i.e. no loose disc.</p>
--	--

7. Trouble shooting

During the remedy of failures section 2 <Safety instructions> shall be absolutely considered.

 Danger	<p><i>When a globe valve is removed from systems conveying dangerous media and shall be carried away from the plant:</i></p> <p>Then the globe valve must be professionally decontaminated.</p>
--	---

Kind of failures	Procedures for remedy	Note
Leakage on the flanges to the system or between body and bonnet	Tighten bolts and nuts. <i>When the valve is still leaking:</i> Remove the valve, considering always the notes in section 2.3 <Special risks> and ask for spare gaskets for the bonnet and correlated instructions at PHOENIX:	<p><u>Note 1:</u> <i>Spare parts shall be ordered with all indications of the marking of the valve. Only the original PHOENIX spare parts shall be used for repairs and replacements</i></p>
Leakage on the flanges to the system or between body and bonnet	<p><u>Globe valves without bellows seal:</u></p> Tighten the nuts of the gland follower alternating and clockwise in little steps of max. ¼ turn to ¼ turn until the leakage stops. In the document <A114R> <i>please see section 8</i> the max. admitted torque for the tightening is specified. <i>In case the leakage cannot be eliminated by this procedure:</i> Repair will be necessary. Ask PHOENIX for new packing and corresponding instructions. <i>In case the nuts of the gland follower shall be loosened or re-moved (anticlockwise turning):</i> <div style="text-align: center;">  <u>Danger to life</u> </div> To protect the staff against possible risks the complete system shall be absolutely depressurized. Mind and consider section 2.3 <Special risks>.	<p><u>Note 2:</u> <i>When it is noted after the disassembling of the valve that the body and/or trim is not sufficiently resistant against attacks of the media opt for more suitable materials of design</i></p>

Operation instructions - Globe valves with actuators

Kind of failures	Procedures for remedy	Note
Leakage on the flanges to the system or between body and bonnet	<p><u>Globe valves with bellows seal :</u></p> <p>The bellows is damaged and shall be replaced as soon as possible, especially when used with corrosive/hazardous media: Repair necessary. Remove the valve from the line, consider section 2.3 <Special risks>. Ask PHOENIX for required spares and corresponding instructions.</p> <p><i>As long as replacement is not possible:</i></p> <p>Retighten stuffing box as described above.</p>	<p><u>Note 1:</u></p> <p><i>Spare parts shall be ordered with all indications of the marking of the valve. Only</i></p>
Leakage in the closed position	<p>Remove the valve (Mind and consider notes of section 2.3 <Special risks>) and check the valve.</p> <p><i>In case of damaged seats:</i></p> <p>Repair necessary: Remove the valve, mind the notes of section 2.3 <Special risks>. Ask PHOENIX for corresponding instructions or send the valve back to PHOENIX for repair.</p>	<p><i>the original PHOENIX spare parts shall be used for repairs and replacements</i></p>
Functional failures	<p>Check stem and stem nut.</p> <p><i>When these functional components are ok but not sufficiently lubricated:</i></p> <p>Clean stem from dirt and contaminations and lubricate with grease compatible with the operating temperatures.</p> <p>For normal operating temperatures lithium saponified greases are sufficient. (Standard grease.....).</p> <p><i>When this procedure will not remedy the failure: :</i></p> <p>Repair necessary: Remove the valve and inspect, mind the notes of section 2.3 <Special risks>. Ask PHOENIX for corresponding spares and required instructions.</p>	<p><u>Note 2:</u></p> <p><i>When it is noted after the disassembling of the valve that the body and/or trim is not sufficiently resistant against at-tacks of the media opt for more suitable materials of design</i></p>

In case of failures of the actuators see attached instructions.

8. Information

The mentioned <Data-sheets>, <Design documents> Repair instructions and other information – also in other languages - you can ask for under

Info@phoenix-valvegroup.com oder <http://www.phoenix-valvegroup.com>

Or at the following address:

PHOENIX Armaturenwerke GmbH
Am Stadtbruch 6
34471 Volkmarsen
Germany

Tel.: 05693-988-0
Fax.: 05693-988-140

Operation instructions - Globe valves with actuators

8.1 Pressure – Temperature-Rating, Excerpt TDB 3/1 to 3/5

The requirements of DIN EN 12516 – 1 are principally fulfilled.

- Low alloyed and not alloyed steels

PN	DN-range	Admitted oper. pressure (bar) at oper.temperatures (°C)						
		-60 *	-10	120	200	300	400	450
10	15-500	7,5	10	10	8	6	6	5
16	15-500	12	16	16	15	12	9	6
25	15-500	18,75	25	25	23	18	14	12
40	15-300	30	40	40	38	30	24	20
63	15-150	47,25	63	63	55	41	35	32
100	15-150	75	100	100	85	62	53	51
160	15-150	120	160	160	130	96	84	81

* AD-W10, Load case II

- Stainless steels

PN	DN-range	Admitted oper. pressure (bar) at oper.temperatures (°C)					
		-196 *	-10	120	200	300	400
10	15-500	10	10	10	8	6	6
16	15-500	16	16	16	15	12	11
25	15-500	25	25	25	23	18	16
40	15-300	40	40	40	36	30	25
63	15-150	63	63	63	50	44	40
100	15-150	100	100	100	80	70	64
160	15-150	160	160	160	130	112	103

* Not valid for SS 1.4581

- Low temperature steels

PN	DN-range	Admitted oper. pressure (bar) at oper.temperatures (°C)					
		-60 *	-50	-10	120	200	300
10	15-500	10	10	10	10	8	6
16	15-500	16	16	16	16	15	12
25	15-500	25	25	25	25	23	18
40	15-300	40	40	40	40	36	30
63	15-150	63	63	63	63	55	41
100	15-150	100	100	100	100	85	62
160	15-150	160	160	160	160	130	96

* 1.0488

For steels not mentioned in these tables the user shall contact the manufacturer/supplier of the valve.

8.2 Equilibrating disc

Combinations of nominal pressures – nominal diameters on the left side of the marked step line can be operated with pressure coming from the lower side of the disc also for the differential pressure equal to nominal pressure.

Combinations of nominal pressures – nominal diameters on the right side of the marked step line normally cannot be operated with equal to nominal pressure. Reference values for differential pressures which still allow a normal operation are indicated in the right side below the marked step line.

For higher differential pressures suitable measures shall be considered, e.g. equilibrating disc, reversion of the shut-off device or by-pass arrangements.

Operation instructions - Globe valves with actuators

Table 1– Permissible differential pressure in bar

PN	DN																	
	15	20	25	32	40	50	65	80	100	125	150	200	250	300	350	400	500	
10																		
16																		
25												13	8	5	4,5	3,5	2	
40										25	13	8	5	4,5	3,5	2		
63								64	55	35	25	13						
100								80	55	35	25	13						
160							125	80	55	35	25	13						

8.2.1 Function of the equilibrating disc

(With preference to be used with valve stem in vertical position)

Valves equipped with an equilibrating disc shall be installed in the system in such a way that the flow (and the pressure) comes from atop the disc.

At closed valve (1) the starter disc (a) will be lifted from its seat by turning the handwheel anti-clockwise. This lift provokes immediately an equilibration of the pressure of the media (2) under the main disc (b). As soon as this balance of pressures is reached up to values mentioned in the table 1, the valve can be operated without supplementary tools or devices by normal hand force by further turning the hand-wheel (3).

