

PHOENIX Armaturenwerke GmbH
Germany

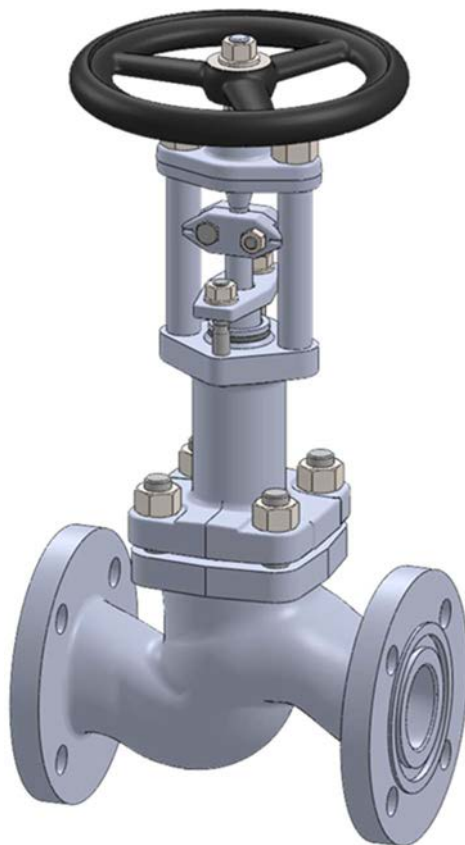

Instruction for Globe Valves
BA 112-AV-E

Edition 2024-04-02



Edition		00		01		02			
Date	Name	08/23	Wo	10/23	Wo	04/24	Wo		
Edition									
Date	Name								

Operation Instruction- Globe Valves

Declaration of conformity acc. to Directive 2014/68/EU

The manufacturer	PHOENIX Armaturenwerke GmbH 34471 Volkmarsen, Germany
declares that the valves	Manufacturer and Brand PHÖNIX: Globe valves with bellows seal and secondary stuffing box seal types 350, 350EC, 355HS, 365, 390, 925, 941 Globe valves with stuffing box seal types 430, 431HS, 919, 935, Brand STRACK: S20, S21, S24, S97, S430, S431HS <ul style="list-style-type: none">• with handwheel and actuator• with square for gear assembling
<ol style="list-style-type: none">1. are pressure bearing equipment within the meaning of the Pressure Equipment Directive 2014/68/EU and in conformity with the requirements of this directive,2. can only be used and operated under observance of the attached operation manual BA 112-AV-E.	

Related standards :

DIN EN 16668	Requirements and testing for metallic valves as pressure accessories Direction for pressure bearing body components Body- and Bonnet Material acc. AD 2000 AD-A4 with Inspection Certificate 3.1 to EN 10204
DIN EN 19	Marking of metallic valves

Description of type and technical features:

PHÖNIX-type datasheets <350, 350EC, 390, 365, 925, 941, 430, 431HS, 919, 935> STRACK-type datasheets < S 20, S 21, S24, S97, S430, S431HS> <i>NOTE: This manufacturer declaration is valid for all variants of types mentioned in the PHOENIX catalogue</i>

Applied procedure for the rating of the conformity:

to Annex III of the Pressure Equipment Directive 2014/68/EU Module „H“

Name of the notified body:

Identification N° of the notified body:

LRQA Deutschland GmbH	0525
------------------------------	-------------

According to the guidelines for the application of the Council's general direction 2014/34/EU of 26.02.2014 for adapting legal regulations valid in the single member countries and dealing with apparatuses and safety systems and their application in areas endangered by explosion, globe valves do not have an integrated potential source of sparks as revealed by the danger of releasing sparks analysis. Due to this, globe valves are not subject to the guideline mentioned above.

Volkmarsen, 29.04.2024

Gunter Wodara, CTO

Operation Instruction- Globe Valves

0 Introduction

This instruction shall support the user for installation, operation and maintenance of globe valve types **350, 350EC, 355HS, 365, 390, 430, 431HS, 919, 925, 935, 941, S20, S21, S24, S430, S431HS, S97.**

	The non observance of the following attention and warning notes might cause dangers with the consequence that the manufacturer's guarantee becomes void.
Attention	For questions in this regard contact the manufacturer, addresses see section 8.

1 Defined use

After their installation in a piping system (either between flanges or by welding) the use of the globe valves **as specified in the section "0"** are exclusively defined as to stop or convey the flow of media within the admitted pressure and temperature limits by manual operation. The safety instructions of section 2 <safety instructions> shall be observed.

The design document <**Pressure-Temperature-Tables TDB3/1 to 3/5**> (see section 8.1 <Information>) shows the admitted pressure-temperature-range for these globe valves.

2. Safety instruction



2.1 General safety instructions

Valves are subject to the same safety impositions, which are valid for the piping system where the valves shall be installed. Therefore, the present instruction mentions only such kind of safety notes which must additionally be considered for valves.

2.2 Safety instructions for the user

It is not within the responsibility of the manufacturer and must be safeguarded by the user of the globe valve that

⇒ the valve is only used as required by the "defined use" as described in section 1,

 Danger to life	Valves whose admitted pressure-temperature range (= "Rating") is not sufficient for the operating conditions shall not be used. For materials or pressures or temperatures not indicated in the a.m. < Pressure-Temperature-Tables TDB 3/1 to 3/5 > a release note from the manufacturer is mandatory. The disregard of this ordinance can provoke danger to life and cause damages in the piping system.
 Note	<i>Globe valves are not suitable for an operation in intermediate position.</i> A globe valve shall only be used with its final positions totally open or totally closed. If the valve should be used with in an intermediate position and/or for a throttling/regulating target, valves with a rigid disc shall be installed.
 Danger	Protection against wrong use of the globe valve: It must be absolutely assured that the selected materials of the wetted parts of the globe valve are suitable for the handled media. The manufacturer is not responsible for damages of the globe valve caused by corrosive agents. The disregard of this ordinance can provoke danger for the user and cause damages in the piping system.

⇒ A gear operator which is fitted to the valve later on shall be adapted to this valve. In the closed position the final stop shall be realised in the seat of the valve,







⇒ The globe valve will be installed workmanlike in the piping system, especially such types of valves which are fitted into the piping system by welding. The wall thickness of the valve body shall be calculated in such a way that an additional load F_z within the usual order of magnitude

Operation Instruction- Globe Valves

($F_z = \pi/4 \cdot DN^2 \cdot PS$) is considered for such a workmanlike mounted piping system.
 (PS = max. admitted design pressure at ambient temperature),

- ⇒ the valve shall be fitted workmanlike with these systems,
- ⇒ inside this piping system the usual flow rates in continuous operation shall not be exceeded and exceptional operating conditions such as vibrations, water hammers, cavitation and higher percentages of solid matters in the media – especially wearing ones – had been cleared with the manufacturer,
- ⇒ globe valves used at operating temperatures $>+50^\circ\text{C}$ or $<-20^\circ\text{C}$, are protected against contact as it is intended for the pertinent piping system,
- ⇒ Only qualified staff is used for the operation and maintenance of pressure bearing piping systems.

2.3 Special risks

 Danger to life	<p>Valves with stuffing box seal</p> <p>The operating stem is sealed by a stuffing box. Before a loosening of the nuts on the gland follower the piping system shall be completely depressurised to avoid the leakage of the media throughout the stuffing box.</p>
 Danger to life	<p>Before the disassembling of the valve out of the piping system and/or before the loosening of the bolts and nuts of the bonnet the system shall be completely depressurised to avoid an uncontrollable fugitive emission of the media. It must be assured that the valve is completely open to enable that the pressure can escape on both sides of the valve.</p>
 Danger	<p><i>Globe valves which are used as final shut-off valve:</i></p> <p>For normal operation, especially with gaseous, hot and/or dangerous media a blind flange or a cover plate shall be fitted on the free outlet or adequately secured against unauthorised operation acc. to the directives of EN 292 – Part 2.</p>
 Danger	<p><i>Globe valves which are not slowly operated in the starting up phase at service temperatures of $>250^\circ\text{C}$:</i></p> <p>Leakages might occur. See also section 6.1. <Starting-up phase></p>
 Danger	<p>Whenever a globe valve which is used as final valve shall be opened under pressure load this must be performed with extraordinary care and in such a manner to assure that the outspurring media cannot provoke damages.</p>
 Danger	<p>When a valve shall be disassembled from the piping system there exists the risk that the media can flow out off the piping or the valve. In case of liquids which are harmful for the health or dangerous the piping system shall be completely drained before the valve can be removed from the system. Caution of residues coming out off or remaining in dead holes of the valve or the piping system itself.</p>

Operation Instruction- Globe Valves

2.4 Marking of the globe valve

Each globe valve is normally marked as follows:

For	Marking	Note
CE-Mark	CE	Corresponding to PED 2014/68/EU valves shall be marked with the CE-mark. only for sizes DN 32 and more
CE-Mark	0525	Nominated body to EU Directive = LRQA Deutschland GmbH Register
Brand	PHÖNIX	Manufacturer PHOENIX Armaturenwerke GmbH
Brand	STRACK	Manufacturer PHOENIX Armaturenwerke GmbH
Manufacturer-N°	e.g.: 98898/02	The first figures before the strike are the factory number, the last figures after the strike = item n° g.g. /02 = item 2 of the order
Date of manufacture	e.g.: 05/02	The first figures before the strike indicate the month of manufacture (05 = May), the figures after the strike = year of manufacture, e.g. (02 = 2002)
Valve type	Type (und Zahlenwert)	e.g., Type 390, see Data-sheet PHOENIX
Body material	e.g.: 1.0619.01	N° of material standard to EN 10027, Part 2
Size	DN or NPS (and numerical value)	Numerical value in mm, e.g., DN 200 or NPS 8
Max. pressure	PS or PN (and numerical value)	Numerical value in [bar] at 20°C, e.g., PS 40
	ANSI and Class (numerical value)	e.g., ANSI 300
Heat-/ Melt N°	e.g.: 25652 or GHW	Heat-/Melt N° of the foundry

Table 1 Marking of the globe valve

3 Transport and Storage

Globe valves shall be carefully treated, transported and stored:

- ⇒ The valve shall be stored with its protecting packing and/or with its protecting caps on the inlet and outlet. Valves with a weight of more than 10 kgs shall be stored on pallets (or similar) and be transported in such a state (even on the transport to the installation point).

 Attention	<p><i>To protect the valve against damages:</i></p> <p>Ropes and belts shall only be fixed on the bonnet but never on the handwheel!</p>
---	--



- ⇒ Before its installation the valve shall be normally stored in closed area and be protected against detrimental influences such as dirt and humidity.
- ⇒ In particular the handwheel and the end orifices of the globe valves for the connection with the piping system shall not be damaged neither by mechanical nor other influences.
- ⇒ Globe valves will be supplied with disc in closed position and shall be stored in this state.

Operation Instruction- Globe Valves

4 Installation into the piping system

4.1. General

For the installation of valves into a system the same instructions are valid as for the connection of pipes among themselves and similar piping components. When in a plant the piping and other equipment are isolated, this must also be applied to the built-in globe valves. In addition the following instructions are valid for globe valves. For the transport to the installation place please mind the information given in section 3 of this manual.

 Danger to life	If globe valves are installed in insulated piping systems, or in the area of other isolated equipment, so they must also be isolate. In absence of insulation, globe valves can be damaged. In serious cases, the pressurized parts could be damaged.
 Attention	<i>To avoid damages of globe valves with weld ends:</i> During the welding of the valves into the piping system the weld procedure shall be performed in such a way that the applied heat energy is limited and distortions of the valve body are avoided. Therefore, larger sizes shall be welded in alternating procedures once from one side and then from the other to avoid restraints in the valve's body. During the weld procedure the globe valve shall be brought and kept in the open position until the weld conjunction is cooled down to <math><100^{\circ}\text{C}</math>.
 Danger to life	In case of a posterior installation of a gear operator the interface adaptation, the nominal moment and the sense of the rotation must be adapted to the globe valve. The globe valve shall be closed by turning the handwheel clockwise. Disregard of this imposition can provoke danger for the user and damages in the piping system.

As far as handwheels are concerned:

 Danger	<i>Handwheels are no "step boards nor ladders"!</i> Handwheel shall not be charged with heavy loads; this can damage or destruct both the handwheel and/or the globe valve.
--	---

4.2 Working steps

- ⇒ Transport the globe valve in its protecting packing to the installation site and unpack the valve just before its immediate fitting into the system to ensure that the valve is protected against each kind of contamination.
- ⇒ Inspect the valve on possible transport damages. Damaged valves shall not be installed.
- ⇒ Make sure that only globe valves will be installed whose pressure rating, type and dimensions of connections correspond to the operating conditions. In this regard also see related marking of the globe valve.

 Danger to life	Globe valves whose admitted pressure-/temperature rating is not sufficient for the operating conditions shall not be installed. This admitted range results in the marking and/or in the design document <Pressure-Temperature-Tables TDB3/1 to 3/5> see also section 1 <Defined use>. Disregard of this precautionary measure can provoke danger to life for the user and damages in the piping system.
--	---

- ⇒ The connections of the piping system shall be in strict alignment with the end connections of the globe valve and have plane-parallel ends.

Operation Instruction- Globe Valves

- ⇒ Before the installation the valve and the corresponding pipe shall be carefully cleaned from dirt and contaminations, especially hard foreign particles shall be removed.
- ⇒ The flow direction of globe valve is marked by an arrow. For special applications and information regarding “equilibrating disc” see section 8 < Information>

 Danger to life	Globe valves shall not be installed against the marked flow direction. Disregard of this precautionary measure can provoke danger to life for the user and damages in the piping system.
--	--

For globe valves with weld ends only:

- ⇒ The weld ends of the valve shall be in true alignment and shall have parallel faces and must be of identical type and materials as the pipes – see type plate of the valve. Opposite weld ends must fit to each other as far as diameters and weld joints are concerned.
- ⇒ Make sure by workmanlike welding that neither worth mentioning tensions will be produced in this piping section or on the valve nor that the globe valve body might get distorted due to unilateral heat introduction during the weld procedure. Only temperatures of <300°C, measured on the body wall, are admitted.
- ⇒ The weldings must be performed workmanlike in such a way that the weld seam has all round about a uniform temperature. Globe valves >DN 300 shall be welded in alternation on their opposite sides.
- ⇒ Weld cables shall not be fixed on the valve itself but exclusively on the pipings.

 Attention	Disregard of these impositions can provoke distortion of the valve body. A permanent distortion in the seat area of the valve can signify that the valve becomes unserviceable.
---	--

5 Pressure test of the piping section.

For the pressure test of globe valves the same instructions are valid as imposed for the piping system. In addition the following shall be considered:

- ⇒ Newly installed pipe system shall be carefully cleansed to flush off all foreign particles.
- ⇒ The test pressure “PT” of an **opened valve** shall **not exceed the value 1,5x PN/PS** by virtue of the marking of the valve.
- ⇒ The test pressure “PT” of a **closed valve** shall **not exceed the value 1,1x PN/PS** by virtue of the marking of the valve.

6 Starting up/ commissioning, normal operation and maintenance.

6.1 Starting up/ Commissioning

When a **globe valve is installed in closed position or as final shut-off device**, during the “starting up phase” of a piping section it must be assured at temperatures of >100°C – especially when globe valves of >DN 300 are involved - that the handled medium will be slowly fed-in. Otherwise, the valve’s body gets distorted and the valve will leak.

6.2 Normal operation and maintenance

Turning the handwheel clockwise provokes the closing of the globe valves and an anticlockwise operation opens the valve. Normal hand force is sufficient for the operation of the handwheel. Only for a tight closure or in the opening phase of the valve increased hand force might be necessary for a short transition time.

Operation Instruction- Globe Valves

The use of **extension rods, levers and similar items to increase the operation moment** is not admitted.

Operation Instruction- Globe Valves



Note

*Globe valves are **not suitable for an operation in intermediate position.***

Globe valves shall only be used in their final position, i.e., either completely opened or closed.

When an intermediate/throttling position is required, the valve shall be equipped with a rigid regulating disc, i.e., no loose disc..

Regular maintenance work is not required for globe valves without live-loaded packing (1),, however, during the inspection of the piping section no leakage shall appear neither on the flanged and/or screwed connections nor on the stuffing box. In case of leakages and repairs please see section 2 – <Safety instructions> and section 7 <Failures>

(1) Springs (A) on live-loaded packing glands per TA-Luft requirements should be frequently inspected. In case of a reduction of the initial load, the packing bolting (B) should be adjusted to establish the specified load (see operation manual sent with valve).

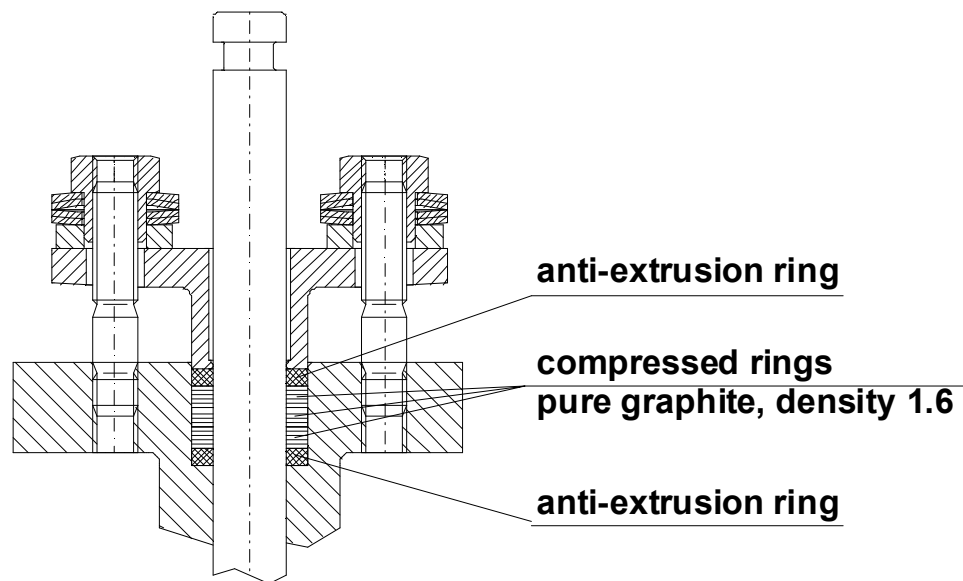

7 Trouble shooting

During the remedy of failures section 2 <Safety instructions> shall be absolutely considered.



Danger

When a globe valve is removed from systems conveying dangerous media and shall be carried away from the plant:

Then the globe valve must be professionally decontaminated.

Operation Instruction- Globe Valves

Kind of failures	Procedures for remedy	Note
Leakage on the flanges to the system or between body and bonnet	<p>Tighten bolts and nuts.</p> <p><i>When the valve is still leaking:</i></p> <p>Remove the valve, considering always the notes in section 2.3 <Special risks> and ask for spare gaskets for the bonnet and correlated instructions at PHOENIX.</p>	<p>Note 1:</p> <p><i>Spare parts shall be ordered with all indications of the marking of the valve. Only the original PHOENIX spare parts shall be used for repairs and replacements</i></p>
Leakage through the packing / stem leakage	<p><u>Globe valves without bellows seal:</u></p> <p>Tighten the nuts of the gland follower alternating and clockwise in little steps of max. ¼ turn to ¼ turn until the leakage stops.</p> <p>In the section 8 the max. admitted torque for the tightening is specified.</p> <p><i>In case the leakage cannot be eliminated by this procedure:</i></p> <p>Repair will be necessary. Ask PHOENIX for new packing and corresponding instructions.</p> <p><i>In case the nuts of the gland follower shall be loosened or re-moved (anticlockwise turning):</i></p> <div style="text-align: center;">  <p><u>Danger to life</u></p> </div> <p>To protect the staff against possible risks the complete system shall be absolutely depressurised.</p> <p>Mind and consider section 2.3 <Special risks>.</p>	<p>Note 2:</p> <p><i>When it is noted after the disassembling of the valve that the body and/or trim is not sufficiently resistant against attacks of the media opt for more suitable materials of design</i></p>

Operation Instruction- Globe Valves

Kind of failures	Procedures for remedy	Note
Leakage through the packing / stem leakage	<p><u>Globe valves with bellows seal:</u> The bellows is damaged and shall be replaced as soon as possible, especially when used with corrosive/hazardous media: Repair necessary. Remove the valve from the line, consider section 2.3 <Special risks>. Ask PHOENIX for required spares and corresponding instructions.</p> <p><i>As long as replacement is not possible :</i> Retighten stuffing box as described above.</p>	<p><u>Note 1:</u> <i>Spare parts shall be ordered with all indications of the marking of the valve. Only the original PHOENIX spare parts shall be used for repairs and replacements</i></p>
Leakage in the closed position	<p>Remove the valve (Mind and consider notes of section 2.3 <Special risks) and check the valve.</p> <p><i>In case of damaged seats:</i> Repair necessary: Remove the valve, mind the notes of section 2.3 <Special risks>. Ask PHOENIX for corresponding instructions or send the valve back to PHOENIX for repair.</p>	<p><u>Note 2:</u> <i>When it is noted after the disassembling of the valve that the body and/or trim is not sufficiently resistant against at-tacks of the media opt for more suitable materials of design</i></p>
Functional failures	<p>Check stem and stem nut.</p> <p><i>When these functional components are ok but not sufficiently lubricated:</i> Clean stem from dirt and contaminations and lubricate with grease compatible with the operating temperatures. For normal operating temperatures lithium saponified greases are sufficient. (standard grease.....).</p> <p><i>When this procedure will not remedy the failure:</i> Repair necessary: Remove the valve and inspect, mind the notes of section 2.3 <Special risks>. Ask PHOENIX for corresponding spares and required instructions.</p>	<p><u>Note 2:</u> <i>When it is noted after the disassembling of the valve that the body and/or trim is not sufficiently resistant against at-tacks of the media opt for more suitable materials of design</i></p>

In case of failures on the actuators see attached instructions.

8 Information

The mentioned <Datasheets>, <Design documents> Repair instructions and other information – also in other languages - you can ask for under

Info@phoenix-Valvegroup.com oder <http://www.phoenix-valvegroup.com>

or at the following address:

PHOENIX Armaturenwerke GmbH
Am Stadtbruch 6
34471 Volkmarsen
Germany

Tel.: 05693-988-0
Fax.: 05693-988-140

Operation Instruction- Globe Valves

8.1 Pressure – Temperature-Rating, Excerpt TDB 3/1 to 3/5

The requirements of DIN EN 12516 – 1 are principally fulfilled.

- Low alloyed and not alloyed steels

PN	DN-range	Admitted oper. pressure (bar) at oper. temperatures (°C)						
		-60*	-10	120	200	300	400	450
10	15-500	7,5	10	10	8	6	6	5
16	15-500	12	16	16	15	12	9	6
25	15-500	18,75	25	25	23	18	14	12
40	15-300	30	40	40	38	30	24	20
63	15-150	47,25	63	63	55	41	35	32
100	15-150	75	100	100	85	62	53	51
160	15-150	120	160	160	130	96	84	81

* AD-W10, Load case II

- Stainless steels

PN	DN-range	Admitted oper. pressure (bar) at oper. temperatures (°C)					
		-196*	-10	120	200	300	400
10	15-500	10	10	10	8	6	6
16	15-500	16	16	16	15	12	11
25	15-500	25	25	25	23	18	16
40	15-300	40	40	40	36	30	25
63	15-150	63	63	63	50	44	40
100	15-150	100	100	100	80	70	64
160	15-150	160	160	160	130	112	103

* Not valid for SS 1.4581

- Low temperature steels

PN	DN-range	Admitted oper. pressure (bar) at oper. temperatures (°C)					
		-60*	-50	-10	120	200	300
10	15-500	10	10	10	10	8	6
16	15-500	16	16	16	16	15	12
25	15-500	25	25	25	25	23	18
40	15-300	40	40	40	40	36	30
63	15-150	63	63	63	63	55	41
100	15-150	100	100	100	100	85	62
160	15-150	160	160	160	160	130	96

* 1.0488

For steels not mentioned in these tables the user shall contact the manufacturer/supplier of the valve.

8.2 Equilibrating disc

Combinations of nominal pressures – nominal diameters on the left side of the marked step line can be operated with pressure coming from the lower side of the disc also for the differential pressure equal to nominal pressure.

Combinations of nominal pressures – nominal diameters on the right side of the marked step line cannot be operated with equal to nominal pressure. Reference values for differential pressures which still allow a normal operation are indicated in the right side below the marked step line.

For higher differential pressures suitable measures shall be considered, e.g., equilibrating disc, reversion of the shut-off device or by-pass arrangements.

Operation Instruction- Globe Valves

Table 1– Permissible differential pressure in bar

PN	DN																		
	10	15	20	25	32	40	50	65	80	100	125	150	200	250	300	350	400	500	
10																			
16																			
25												21	13	8	5	4,5	3,5	2	
40												21	13	8	5	4,5	3,5	2	
63									64	55	35	21	13						
100									80	55	35	21	13						
160								12 5	80	55	35	21	13						

Torques for to close the valve – seat tightness test with air or nitrogen.

DN	Pressure below the seat [bar]	Torque to close the valve [Nm]
15-25	40	
32-50	40	
80	40	110
100	40	150
150	21	>250 </= 300

8.2.1 Function of the equilibrating disc

(With preference to be used with valve stem in vertical position)

Valves equipped with an equilibrating disc shall be installed in the system in such a way that the flow (and the pressure) comes from atop the disc.

At closed valve (1) the starter disc (a) will be lifted from its seat by turning the handwheel anti-clockwise. This lift provokes immediately an equilibration of the pressure of the media (2) under the main disc (b). As soon as this balance of pressures is reached up to values mentioned in the table 1, the valve can be operated without supplementary tools or devices by normal hand force by further turning the hand-wheel (3).

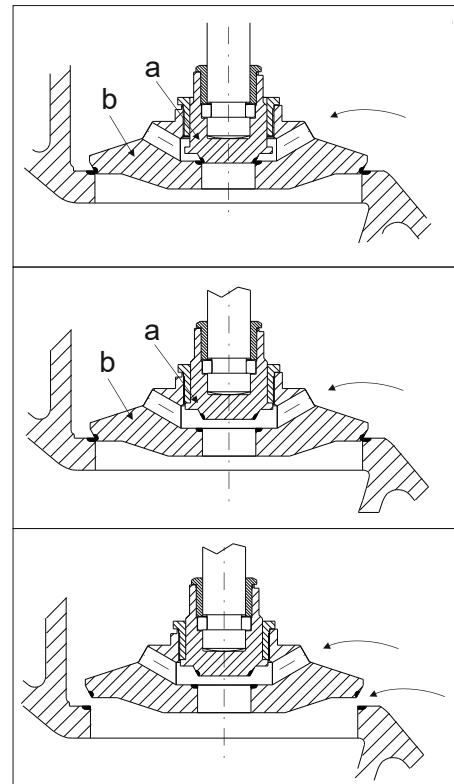

Operation Instruction- Globe Valves

8.2 Torques

Torques [Nm] for bolts nuts for valves only with gland packing

AA 329

Blatt 1/2

DN	Graphitpackung (Kombinationspackung einbezogen)					PTFE-Packungen (unterschiedliche Ausführung)				
	PN 25 ANSI 150	PN 40	PN 63 ANSI 300	PN 100	PN 160 ANSI 900	PN 25 ANSI 150	PN 40	PN 63 ANSI 300	PN 100	PN 160 ANSI 900
10 / 15	10	12	15	20	25	8	10	12	15	25
20	10	12	15	20	25	8	10	12	15	25
25	10	12	15	20	25	8	10	12	15	25
32	10	16	20	25	30	8	16	14	25	30
40	10	16	20	25	30	8	16	14	25	30
50	10	16	20	25	30	8	16	14	25	30
65	10	16	20	25	30	8	16	14	25	30
80	10	30	30	45	50	10	25	25	40	45
100	20	30	30	45	50	16	25	25	40	45
125	20	30	30	45	50	16	25	25	40	45
150	24	40	50	90	95	24	36	40	80	90
200	26	40	60	130	135	26	36	50	125	130
250	30	40	90	180	190	30	36	80	180	185
300	34	50	90			36	39	80		
350	36	50	110			36	39	100		
400	36	50	120			36	40	110		
500	40	50	130			40	40	120		

DN	Graphitpackung (Kombinationspackung einbezogen)					PTFE-Packungen (unterschiedliche Ausführung)				
	PN 250 ANSI 1500	PN 320	PN400 ANSI 2500	PN 500	PN 630	PN 250 ANSI 1500	PN 320	PN400 ANSI 2500	PN 500	PN 630
10 / 15	32	32	32	32	35	25	25	25	25	27
20	32	32	32	32	35	25	25	25	25	27
25	32	32	32	32	35	25	25	25	25	27
32	80	80	140	140	145	135	135	135	135	137
40	80	80	140	140	145	135	135	135	135	137
50	80	80	140	140	145	135	135	135	135	137
65										
80										
100										
125										
150										
200										
250										
300										
350										
400										
500										

Operation Instruction- Globe Valves

Torques [Nm] for bolts and nuts for valves with bellows sealed stem design and safety gland packing

AA-329-1

DN	Graphitpackung (Kombinationspackung einbezogen)						PTFE-Packungen (unterschiedliche Ausführung)				
	PN 25 ANSI 150	PN 40	PN 63 ANSI 300	PN 100	PN 160 ANSI 900	PN 250 ANSI 1500	PN 25 ANSI 150	PN 40	PN 63 ANSI 300	PN 100	PN 160 ANSI 900
10 / 15	4	5	5	6	8	32	4	5	5	6	8
20	4	5	5	6	8	32	4	5	5	6	8
25	4	5	5	6	8	32	4	5	5	6	8
32	4	8	8	9	12	140	4	8	8	9	12
40	4	8	8	9	12	140	4	8	8	9	12
50	4	8	8	9	12	140	4	8	8	9	12
65	4	8	8	9	12		4	8	8	9	12
80	5	12	12	13	15		5	12	12	13	15
100	8	19	19	20	25		8	19	19	20	25
125	8	19	19	22	25		8	19	19	22	25
150	12	30	30	32	34		12	36	36		
200	13	36					13	36			
250	15	36					15	36			
300	18	39					18	39			
350	18	39					18	39			
400	18	40					18	40			
500	20	40					20	40			



**Valve
& Automation**

Total Valve & Control Solutions®

JOHANNESBURG
Tel: 011 397 2833

South Africa:
0861 103 103

DURBAN
Tel: 031 579 2593

E-mail: sales@valve.co.za
www.valve.co.za



SCAN ME