

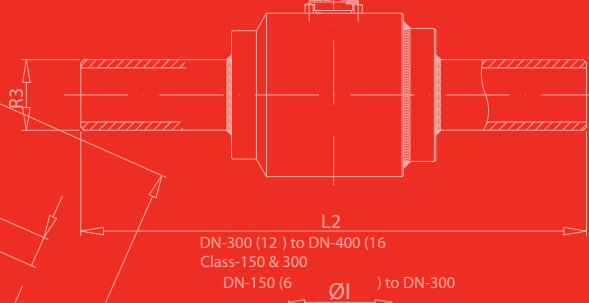

V&A

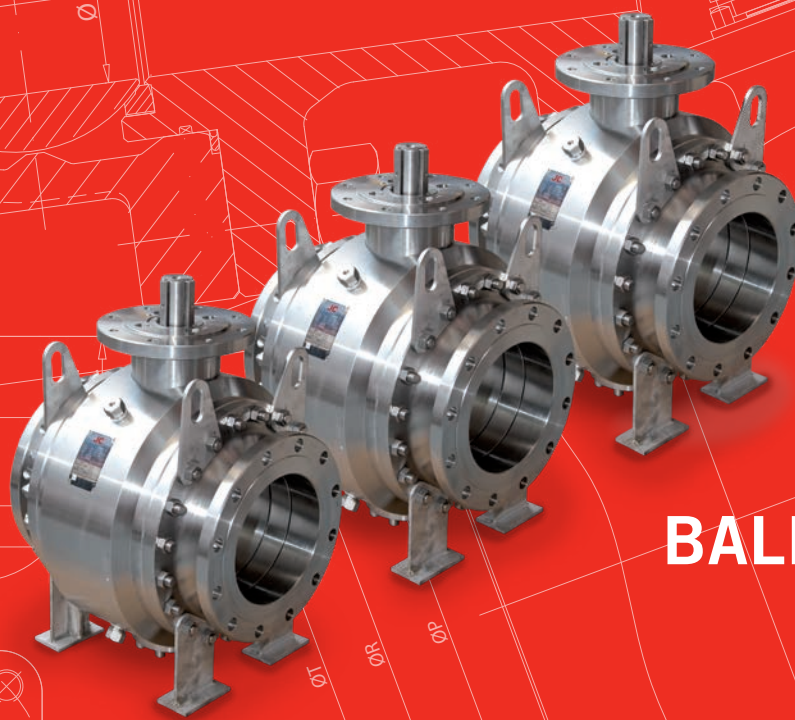

JC
VALVES
The quality option



BALL VALVES

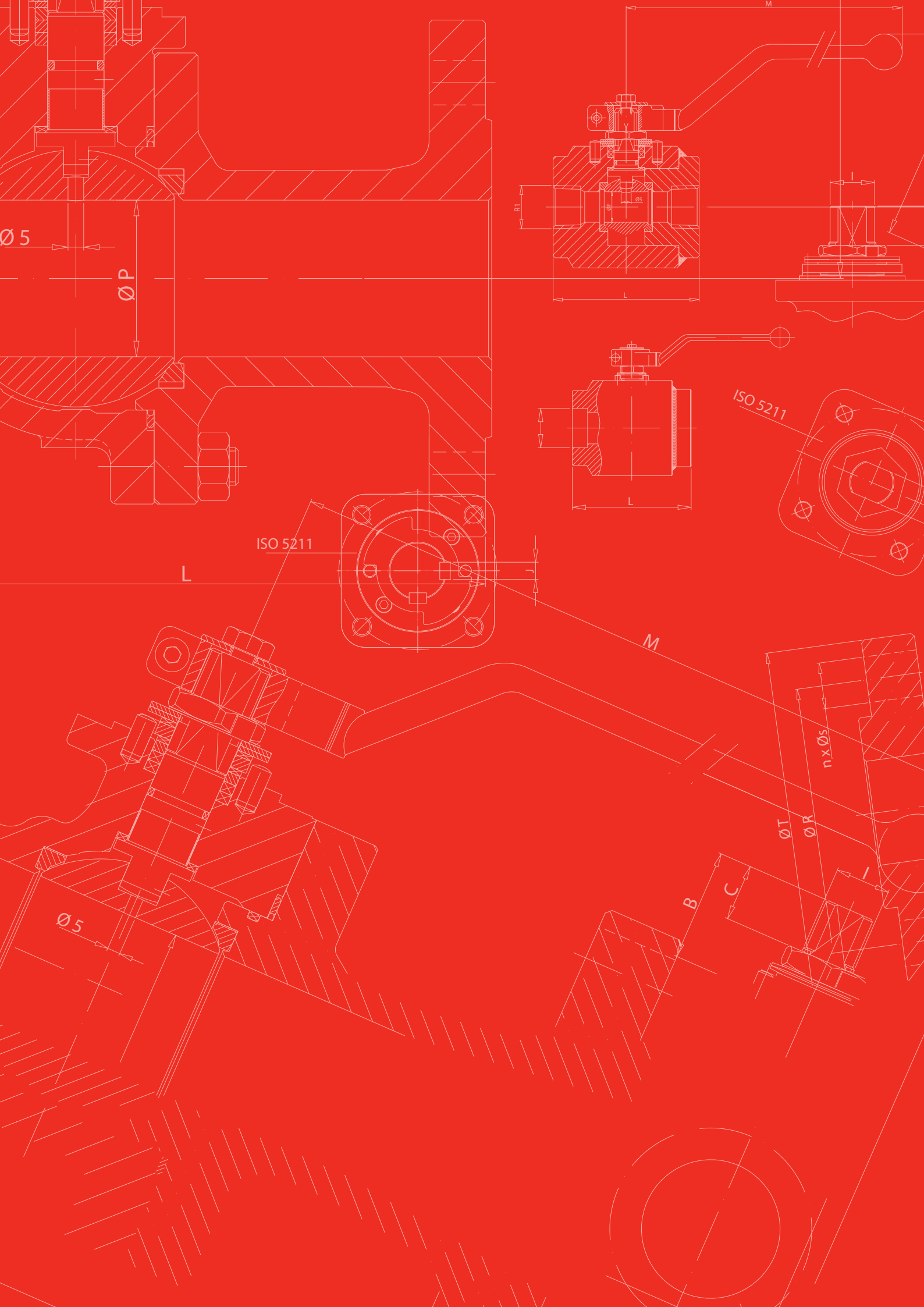



| INDEX |

2

JC VALVES

The company

5

GENERAL HIGHLIGHTS

6

METAL SEATED BALL VALVES

22

TRUNNION MOUNTED BALL VALVES

30

FLOATING ASME BALL VALVES

36

3 PIECE FORGED BALL VALVES

40

MONOBLOCK VALVES

44

SEMI-TRUNNION BALL VALVES

48

FLOATING EN-DIN BALL VALVES

54

FLOATING 3-WAY BALL VALVES

58

SPECIAL CONSTRUCTIONS



The quality option



"We make valves since 1968"

JC Fábrica de Válvulas S.A.U., established in 1968, is a multinational company specialised in the manufacture and sale of high quality industrial valves.

The expertise and know how acquired over the years coupled with the continued investments in the design of valves, has made JC a world renowned company in the field of valve applications.

» Market sectors

JC develops and designs valves for all applications, but the main focus is in Oil & Gas, Chemical, Petrochemical, Pulp & Paper and Energy sectors.



Oil



Chemical



Gas



Pulp & Paper



Petrochemical



Energy



» JC World Wide

JC Valves provides world wide coverage thanks to the strategic locations of its factories and offices:



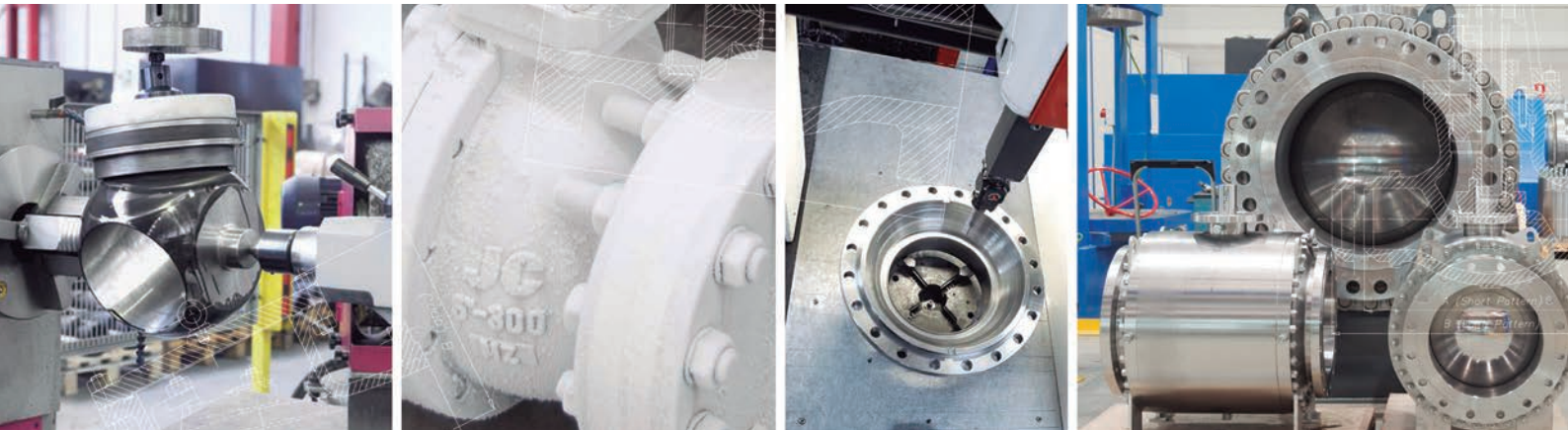

» Global services

JC Fábrica de Válvulas S.A.U. offers its customers a world wide service, from technical advice to choose the right valve up to the design and manufacture of custom built valves to meet special service requirements.

Our R+D department is always ready to find solutions for severe applications and our global distribution network offers quick availability of JC valves and an efficient after sales service.





The quality option

» Quality assurance

JC Valves are designed and produced to meet the major international standards and we take great care and put a lot of emphasis on QUALITY, which provides our customers with a total guarantee and trouble free operation of their process. And in addition, we take great care to make our facilities and our products Environment friendly.

JC Quality Assurance System

- ISO 9001 certified by BV
- PED 2014/68/EU certified by BV (Module H1)

Products Approvals

- API 6D and API 600 certified by the AMERICAN PETROLEUM INSTITUTE
- CE Marking in accordance with PED 2014/68/EU certified by BV
- Fire Safe according to ISO 10497, API 607 and API 6FA
- TR CU 010, TR CU 012, TR CU 032 for Russian market
- SIL (Safety Integrity Level) certified by BV
- ATEX 2014/34/EU
- EN 13774
- TA-LUFT, ISO-EN 15848-1

Environmental Certifications

- ISO 14001 certified by BV



API 6D
6D-0197



API 600
600-0016



PED 2014/68/EU

FUGITIVE EMISSIONS
EN-ISO 15848-1



TP TC 010/2011
TP TC 012/2011
TP TC 032/2013

FIRE SAFE
ISO 10497
API 607
API 6FA



TA-LUFT



GENERAL HIGHLIGHTS

- » Full and Reduced bore
- » Floating and Trunnion mounted ball
- » Soft and Metal seats
- » Castings Quality as per ASME B16.34 Mandatory Appendix I to IV in ASME valves and Severity Levels S3-V3 to DIN 1690 and EN 10203 in EN-DIN valves
- » Polished ball Ra 1 in soft seated valves (in metal seated valves ball is lapped); grinded stem Ra 1.6
- » Full traceability of shell components, upon request, ball and stem as per EN 10204 3.1
- » Antistatic device integral with the stem
- » Viton A, Aflas or Kalrez primary stem seal and secondary graphite packing
- » NACE MR.01.75 wetted parts and bolting as Standard
- » Fire safe as standard construction ISO 10497, API 607 and API 6FA
- » Fugitive emissions EN-ISO 15848-1
- » TA-LUFT VDI 2440
- » SIL (Safety Integrity Level)

| BALL VALVES |

METAL SEATED

½" - 24" | Class 150 - Class 1500
DN 15 - DN 300 | PN 16 - PN 40



JC offers also a large range of metal seated ball valves for different services (slurries, pulp and liquors, high temperature, abrasive or sticking fluids, control).

- » **Bubble tight sealing up to 327 °C and Rate D up to 500 °C**
- » **Low coefficient of friction**
- » **Excellent sliding and running properties**
- » **Hardens the complete surface of ball and seats**

WHY METAL SEATED BALL VALVES?

METAL SEATED BALL VALVES ARE MAINLY USED FOR HEAVY DUTY APPLICATIONS SUCH AS:

- » **High temperatures: above 260 °C** the use of soft seats is not recommended.
- » **Abrasive media: even small particles can damage soft seats.**
- » **High Velocity in opening/closing cycles: this action can perfectly deform the soft ring and destroy the seat.**

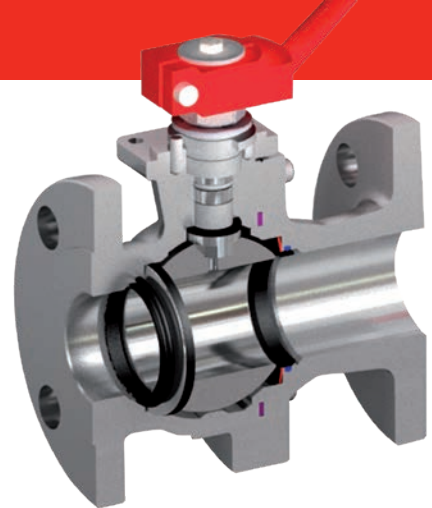

HARDERING TREATMENTS

TCC

Corrosion Resistance: Medium

Abrasion Resistance: High

Is a Tungsten Carbide coating in a metallic matrix bonded to the base material by HVOF methods. This treatment gives a very good resistance to abrasion and impact.



CCC

Corrosion Resistance: High

Abrasion Resistance: High

Is a Chromium Carbide coating in a nickel-chrome base in a metallic matrix bonded mechanically to the base material by HVOF methods. This treatment gives a very good resistance to abrasion and is the best choice for severe corrosion applications.



HT-65

Corrosion Resistance: Medium

Abrasion Resistance: Medium

This is an exclusive treatment developed by JC with two main advantages, first all the ball and seat surface is hardened and second there is no additional overlay on the seat surface. This gives a very good tightness and a lower torque. The surface is hardened to 70 Rockwell C.

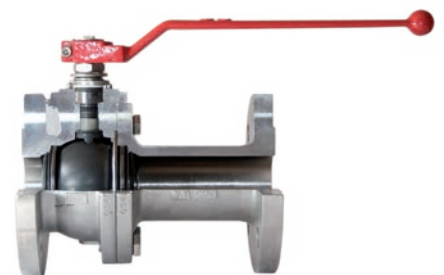

DIFFERENT SEAT DESIGNS

Metallic Seat
with O'ring

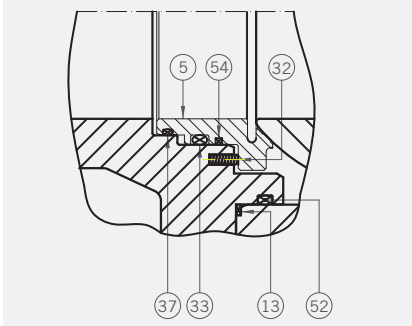

- ⑤ Seat
- ③② Helical spring
- ③③ ③⑦ O'rings
- ①③ ⑤④ Graphite gasket
- ⑤② O'ring

Metallic Seat
with Graphite

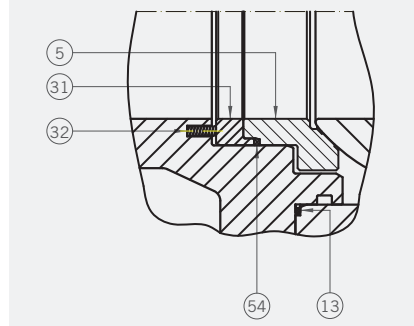

- ⑤ Seat
- ①③ Spiralwound
- ③① Seat carrier
- ③② Helical spring
- ⑤④ Graphite gasket

Metallic Seat
for Floating Valves

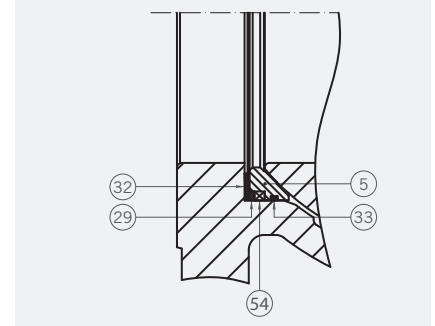

- ⑤ Seat
- ②⑨ Washer
- ③③ O'ring
- ③② Belleville spring
- ⑤④ Graphite gasket

RANGE OF METAL SEATED BALL VALVES

JC can produce the following metal seated ball valves:

Pressure Class	Floating	Monoblock	Trunnion
150	1/2" up to 8"	-	2" up to 24"
300	1/2" up to 4"	-	2" up to 24"
600	1/2" up to 2"	-	2" up to 24"
800	-	1/2" up to 2"	-
900	-	-	2" up to 12"
1500	-	1/2" up to 2"	2" up to 8"

PRODUCTION OF METAL SEATED BALL VALVES

Metal seated ball valves are mainly used for heavy duty applications.

One of the main advantages of using JC metal seated ball valves is the fact that we can transform a soft seated stock valves into a metal seated valve.

THE STEPS TO BE DONE ARE:

- » Re-machining of the body.
- » Lapping of the ball and seats.
- » Hardening treatment to ball and seats.
- » Final adjustment of the ball with its seats.
- » Assembly and test.



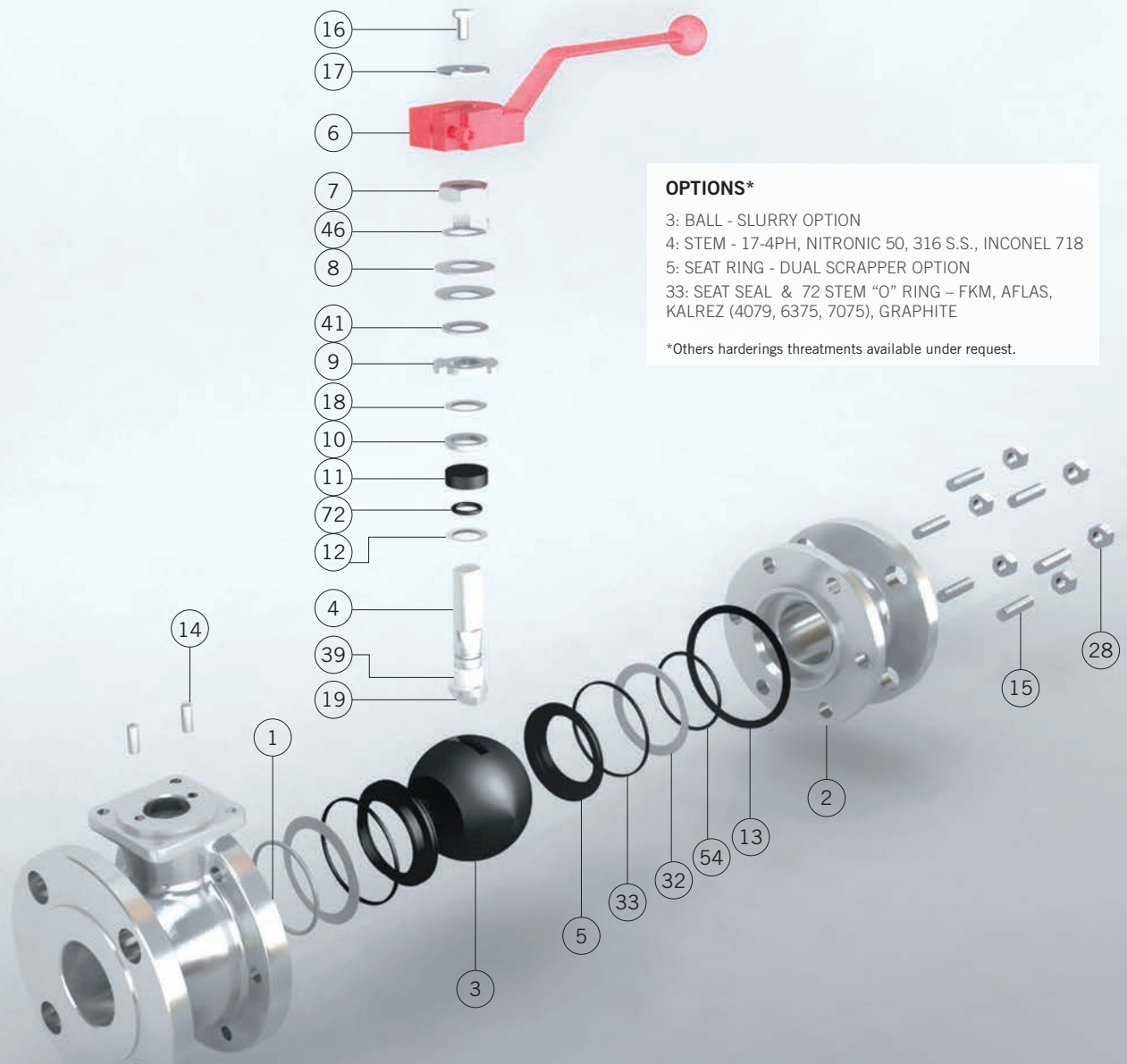

OPTIONS*

3: BALL - SLURRY OPTION
 4: STEM - 17-4PH, NITRONIC 50, 316 S.S., INCONEL 718
 5: SEAT RING - DUAL SCRAPER OPTION
 33: SEAT SEAL & 72 STEM "O" RING – FKM, AFLAS, KALREZ (4079, 6375, 7075), GRAPHITE

*Others hardenings treatments available under request.

Item	Description	EN-DIN		ASME	
		3516 AIM 3540 AIM	3516 IIM 3540 IIM	3515 AIM 3530 AIM	3515 IIM 3530 IIM
1	Body	1.0619	1.4408	A216 Gr.WCB (C≤0,25%)	A351 Gr. CF8M
2	Body connector	1.0619	1.4408	A216 Gr.WCB (C≤0,25%)	A351 Gr. CF8M
3	Ball	A182 F316 or A351Gr. CF8M (Treatments CT-70, CC-60 or HT-65)		A182 F316 or A351Gr. CF8M (Treatments CT-70, CC-60 or HT-65)	
4	Stem	See options		See options	
5	Seat ring	A182 F316 or A351Gr. CF8M (Treatments CT-70, CC-60 or HT-65)		A182 F316 or A351Gr. CF8M (Treatments CT-70, CC-60 or HT-65)	
6	Wrench	Nodular Iron		Nodular Iron	
7	Gland nut	Zinc plated carbon steel	AISI 303	Zinc plated carbon steel	AISI 303
8	Disk spring	Carbon steel	ENP Carbon Steel	Carbon steel	ENP Carbon Steel
9	Stop plate	Carbon steel	AISI 304	Carbon steel	AISI 304
10	Gland	AISI 303	AISI 316	AISI 303	AISI 316
11	Gland packing	Graphite		Graphite	
12	Stem thrust seal	316 S.S. + HT-65		316 S.S. + HT-65	
13	Body connector seal	AISI 316L +Graphite		AISI 316L + Graphite	
14	Stop pin	Carbon St.	Stainless St.	Carbon St.	Stainless St.
15	Stud (DN 32 to DN 100)	A4-70		A193Gr. B7M Zinc dichromate	A193 Gr. B8M
16	Bolt	DIN 933 A4-70		DIN 933 A4-70	
17	Washer	Zinc plated carbon steel	AISI 304	Zinc plated carbon steel	AISI 304
18	Thrust washer	316 S.S. + HT65		316 S.S. + HT65	
19	Antistatic device	Stainless St.		Stainless St.	
28	Nut (DN 32 to DN 100)	A4-70		A194 Gr. 2HM Zinc dichromate	A194 Gr. 8M
32	Seat disk spring	Inconel 718		Inconel 718	
33	Seat Ring	See options		See options	
39	Stem bushing	25% G.F. PTFE		25% G.F. PTFE	
41	Spacer (DN 40 to DN200)	Carbon steel	AISI 304	Carbon steel	AISI 304
46	Locking washer	AISI 304		AISI 304	
54	Seat Seal	Graphite		Graphite	
72	Stem "O" Ring	See options		See options	

EN-DIN 3516 / 3540

PN 16 / 40

Full Bore

PN 16. From DN 65 to DN 200

PN 40. From DN 15 to DN 150

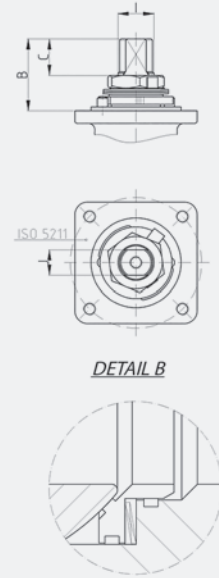
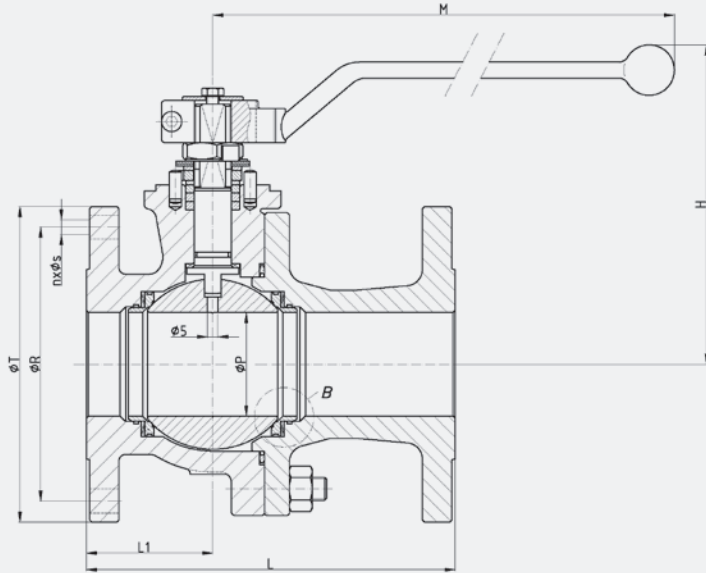

(*) Dimensions of diameters of drills ISO 5211 refer to table from page 60.

Pressure - Temperature

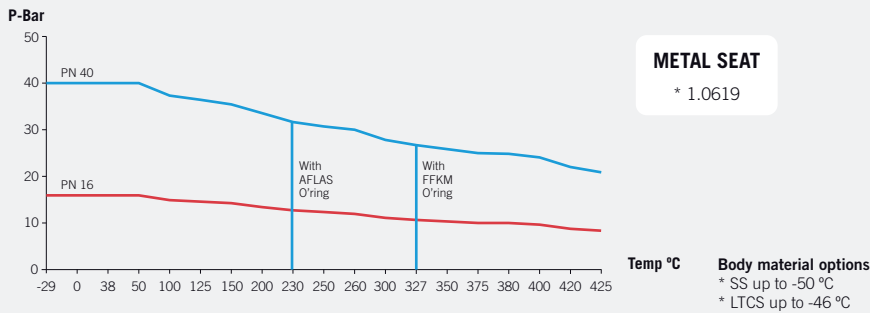

Fig. 3516 (PN 16)

DN	ØP	L	L1	ØR	n x ØS	ØT	H	M	ISO 5211	B	C	I	J	WEIGHT ₃₅₁₆	TORQUE	Kv
65	65	170	75,5	145	4x18	185	168,9	348	F07	44	18,6	M22x1,5	16	16	95	550
80	80	180	82	160	8x18	200	206,9	445	F10	44,5	18,6	M25x1,5	18	22	234	1.000
100	100	190	90,5	180	8x18	220	231,7	495	F10	56,5	27,8	M28x1,5	20	32	330	1.650
125	125	325	120	210	8x18	250	265	698	F12	56	24,75	M35x2	25	52,5	595	3.000
150	151	350	135	240	8x22	285	298	698	F12	68	37,1	M40x2	29	76	820	4.200
(1) 200	203	400	200	295	12x22	340	353,1	868	F14	72	36,5	M45x2	32	111	1.200	9.000

Fig. 3540 (PN 40)

DN	ØP	L	L1	ØR	n x ØS	ØT	H	M	ISO 5211	B	C	I	J	WEIGHT ₃₅₄₀	TORQUE	Kv
15	15	115	53	65	4x14	95	111	164	F05	11,2	5	M12x1,5	9	2,8	21	20
20	20	120	52	75	4x14	105	118	164	F05	14,7	8,5	M12x1,5	9	3,6	27	20
25	25	125	48,5	85	4x14	115	130	164	F05	22,7	9,5	M12x1,5	9	5	29	75
(3) 32	32	130	54	100	4x18	140	131	210	F05	32	13	M16x1,5	12	7	50	130
(3) 40	40	140	55	110	4x18	150	148	213	F07	41,5	18,3	M18x1,5	13	9	65	170
(3) 50	50	150	61	125	4x18	165	155	213	F07	41,5	18,3	M18x1,5	13	12	86	270
(3) 65	65	170	75,5	145	8x18	185	169	348	F07	44	18,6	M22x1,5	16	17	95	550
(2) 80	80	180	74,5	160	8x18	200	207	445	F10	44,5	18,6	M25x1,5	18	23	234	1.000
(2) 100	100	190	91	190	8x22	235	232	495	F10	56,5	27,8	M28x1,5	20	35	330	1.650
(2) 125	125	325	120	220	8x26	270	265	698	F12	56	24,8	M35x2	25	57	595	3.000
(2) 150	151	350	135	250	8x26	300	298	698	F12	68	37,1	M40x2	29	83,5	820	4.200

Dimensions in mm, weight in kg and Torque in Nm.
Weights and dimensions can be changed without notice.
(1) Limited to 10 bar. (2) Limited to 16 bar. (3) Limited to 21 bar.

ASME 3515 / 3530

Class 150 / 300

Full Bore

Class 150. From ½" to 8"

Class 300. From ½" to 6"

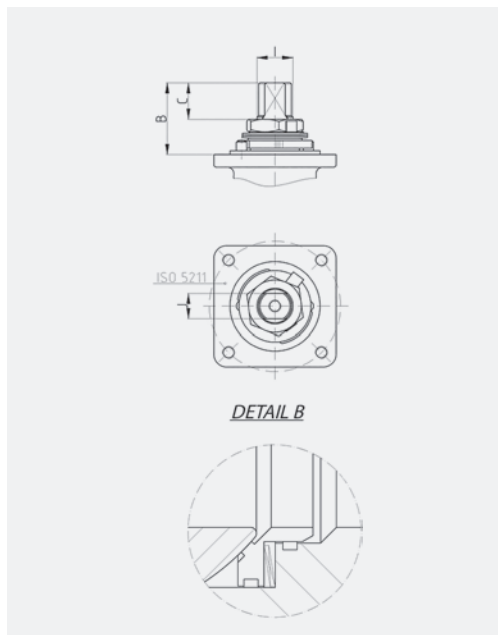
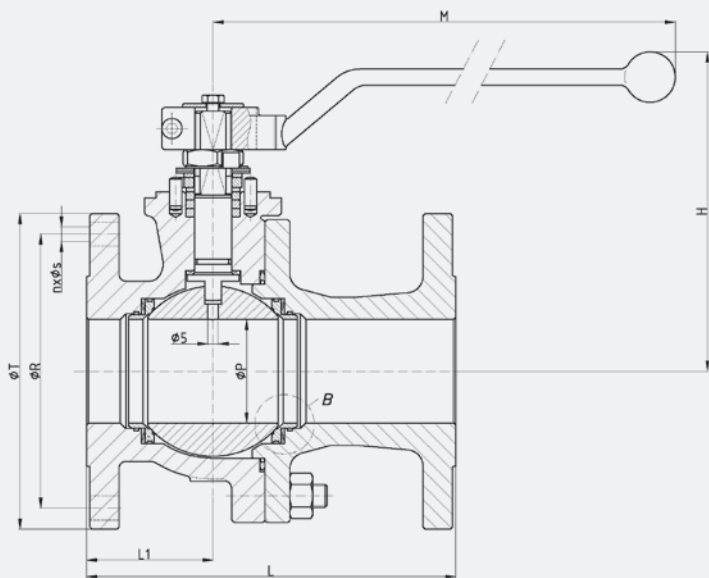

(*) Dimensions of diameters of drills ISO 5211 refer to table from page 60.

Pressure - Temperature

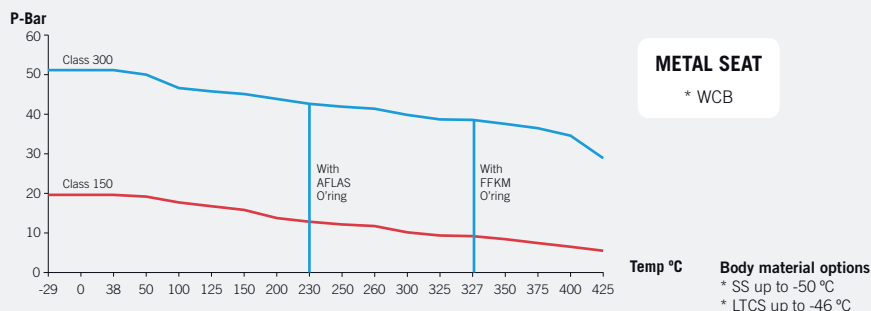

Fig. 3515 (Class 150)

DN	øP	L	L1	øR	n x øS	øT	H	M	ISO 5211	B	C	I	J	WEIGHT	TORQUE	Kv
15 (½")	15	108	47	60,3	4x15,9	90	111	164	F05	11,2	5	M12x1,5	9	2	20	20
20 (¾")	20	117	50	69,9	4x15,9	100	118	164	F05	14,7	8,5	M12x1,5	9	3	26	40
25 (1")	25	127	52	79,4	4x15,9	110	130	164	F05	22,7	9,5	M12x1,5	9	3,5	27	75
40 (1½")	40	165	65	98,4	4x15,9	125	148	213	F07	41,5	18,3	M18x1,5	13	8	70	170
50 (2")	50	178	61	120,7	4x19,1	150	155	213	F07	41,5	18,3	M18x1,5	13	11	88	270
(3) 65 (2½")	65	190	75	139,7	4x19,1	180	169	348	F07	44	18,6	M22x1,5	16	16	110	550
(2) 80 (3")	80	203	78,5	152,4	4x19,1	190	207	445	F10	44,5	18,6	M25x1,5	18	23	234	1.000
(2) 100 (4")	100	229	90	190,5	8x19,1	230	232	495	F10	56,5	27,8	M28x1,5	20	38	330	1.650
(2) 150 (6")	151	394	174	241,3	8x22,2	280	298	698	F12	68	37,1	M40x2	29	88	820	4.200
(1) 200 (8")	203	457	200	298,5	8x22,2	345	353	868	F14	72	36,5	M45x2	32	155	1.200	9.000

Fig. 3530 (Class 300)

DN	øP	L	L1	øR	n x øS	øT	H	M	ISO 5211	B	C	I	J	WEIGHT	TORQUE	Kv
15 (½")	15	140	60	66,7	4x15,9	95	111	164	F05	11,2	5	M12x1,5	9	3	22	20
20 (¾")	20	152	65	82,6	4x19,1	115	118	164	F05	14,7	8,5	M12x1,5	9	4	29	40
25 (1")	25	165	70	88,9	4x19,1	125	130	164	F05	22,7	9,5	M12x1,5	9	5	35	75
(3) 40 (1½")	40	190	80	114,3	4x22,2	155	148	213	F07	41,5	18,3	M18x1,5	13	11	70	170
(3) 50 (2")	50	216	83	127	8x19,1	165	155	213	F07	41,5	18,3	M18x1,5	13	14	88	270
(2) 80 (3")	80	282	118	168,3	8x22,2	210	207	445	F10	44,5	18,6	M25x1,5	18	32	234	1.000
(2) 100 (4")	100	305	133	200	8x22,2	255	232	495	F10	56,5	27,8	M28x1,5	20	52	330	1.650

Dimensions in mm, weight in kg and Torque in Nm.
Weights and dimensions can be changed without notice.
(1) Limited to 10 bar. (2) Limited to 16 bar. (3) Limited to 21 bar.

| BALL VALVES |

METAL SEATED UDV

1/2" - 2" | Class 800 - Class 1500

The Ultimate Drain Valve (UDV) it is a high temperature special design. The valve has got a monobloc welded body and it is reduced bore. This valve is designed to support high temperatures at high pressures.

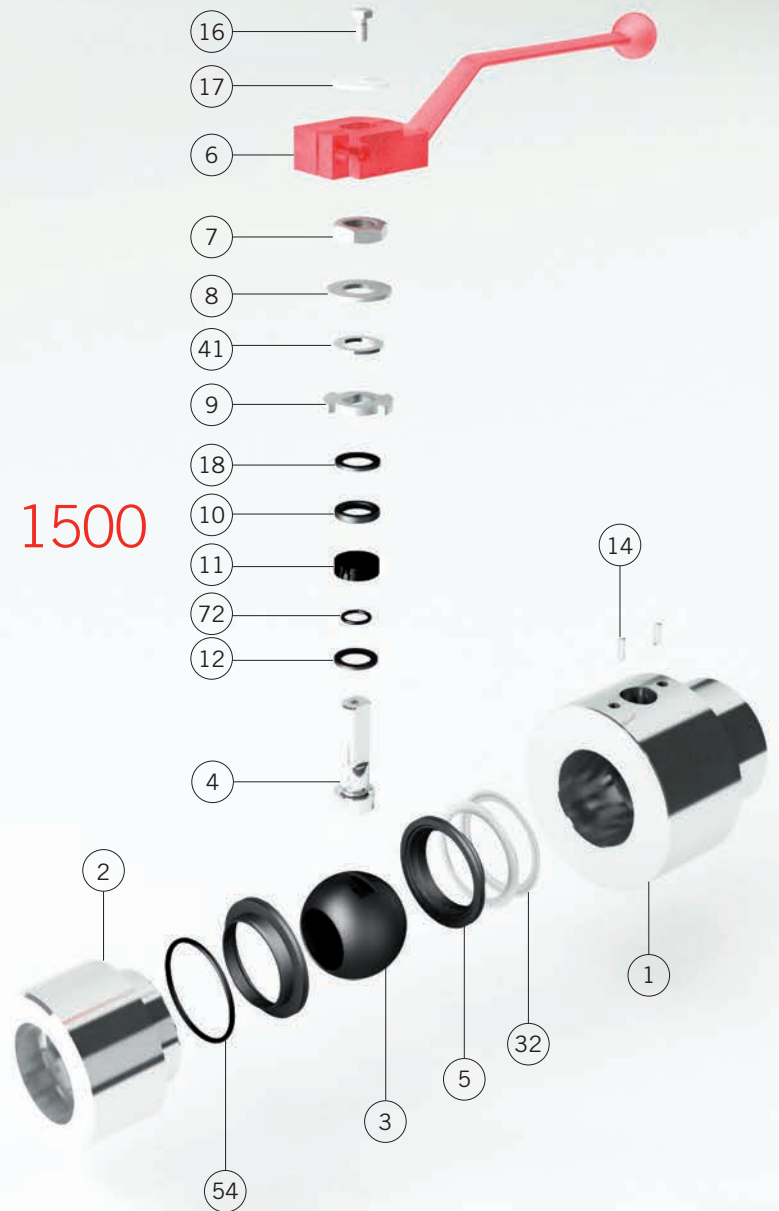

Materials

METAL SEATED UDV

Item	Description	C.S. BODY	S.S. BODY
1	Body	A 105	A 479 Type 316
2	Body connector	A 105	A 479 Type 316
3	Ball	AISI 316 + HT-65 (*)	
4	Stem	17-4 PH + HT-65 (*)	
5	Metallic seat	AISI 316 + HT-65	
6	Wrench	GGG-40	
7	Gland nut	Zinc plated carbon st.	AISI 303
8	Disk spring	Carbon St.	E.N.P. Carbon St.
9	Stop plate	Carbon St.	AISI 304
10	Gland	AISI 316 + HT-65	
11	Gland packing	Graphite	
12	Stem thrust seal	AISI 316 + HT-65	
14	Stop pin	Carbon St.	Stainless St.
16	Bolt	DIN 933 5.6 Zinc plated	DIN 933 A2
17	Washer	Carbon St.	Stainless St.
18	Thrust washer	AISI 316 + HT-65	
32	Disk spring	Inconel 718	
41	Spacer	Carbon St.	Stainless St.
54	Seat gasket	Graphite	
72	O'ring	AFlas	

(*) Other materials under request.

UDV CLASS 800 & 1500 AIM & IIM TYPE

Class 800 / 1500

Reduced Bore

Class 800. From 1/2" to 2"

Class 1500. From 1/2" to 2"

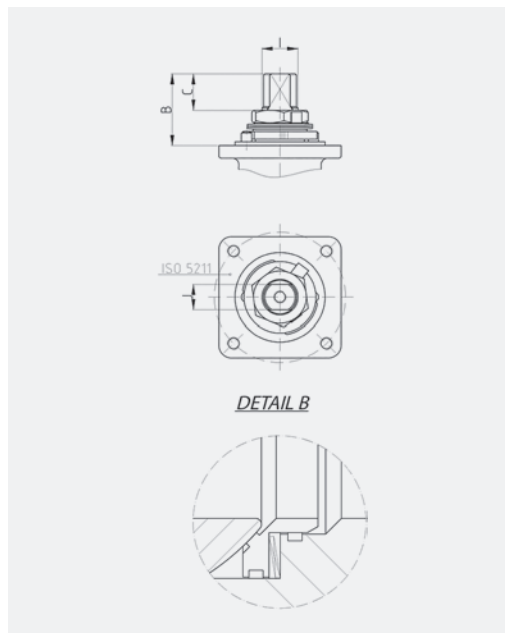
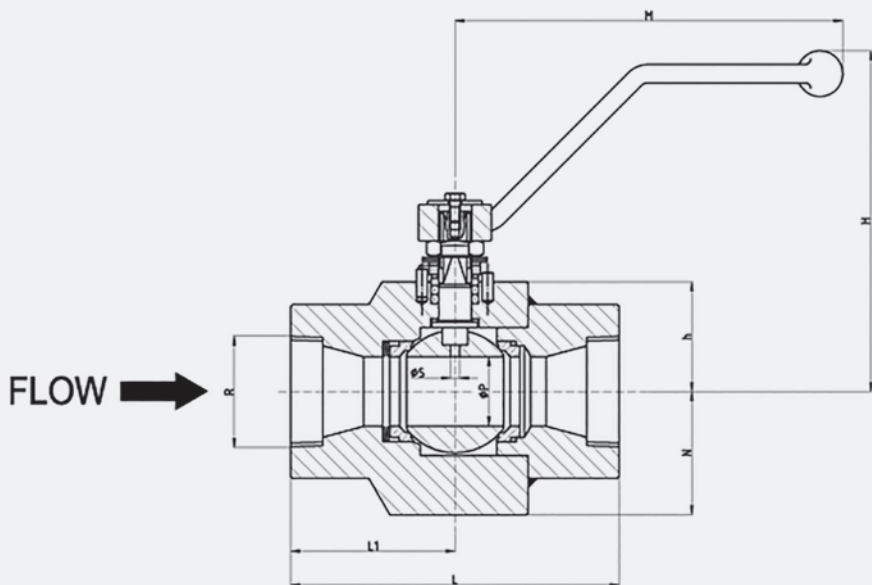

(*) Diameter of drills ISO 5211 = n x F.

Pressure - Temperature

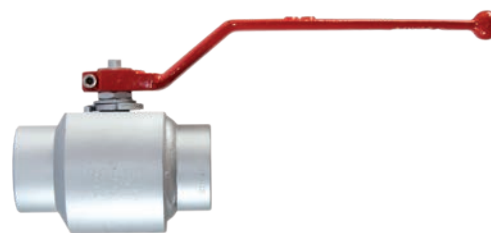
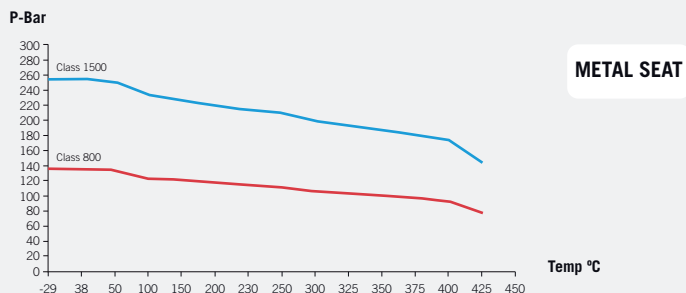

Fig. UDV (Class 800)

DN	ØP	L	L1	R	N	h	H	M	ISO 5211	B	C	I	J	WEIGHT	TORQUE	Kv
1/2"	15	90	45	NPT	37,5	32	103	164	F04	18,7	6,5	M12x1,5	9	3,5	30	11
3/4"	15	110	55	NPT	37,5	32	103	164	F04	18,7	6,5	M12x1,5	9	4,5	30	11
1"	20	120	60	NPT	42,5	35,5	106	164	F05	20	8	M12x1,5	9	5	37	14
1 1/2"	28	150	75	NPT	60	50	112	210	F05	31,5	14,8	M16x1,5	12	6	102	30
2"	36	180	90	NPT	67,5	60	129	213	F07	38,5	18,3	M18x1,5	13	10	173	72

Fig. UDV (Class 1500)

DN	ØP	L	L1	R	N	h	H	M	ISO 5211	B	C	I	J	WEIGHT	TORQUE	Kv
1/2"	15	90	45	NPT	37,5	32	103	164	F04	18,7	6,5	M12x1,5	9	3,5	39	11
3/4"	15	110	55	NPT	37,5	32	103	164	F04	18,7	6,5	M12x1,5	9	4,5	39	11
1"	20	120	60	NPT	42,5	35,5	106	164	F05	20	8	M12x1,5	9	5	54	14
1 1/2"	28	150	75	NPT	60	50	112	210	F05	31,5	14,8	M16x1,5	12	6	161	30
2"	36	180	90	NPT	67,5	60	129	213	F07	38,5	18,3	M18x1,5	13	10	287	72

Dimensions in mm, weight in kg and Torque in Nm. Weights and dimensions can be changed without notice.

| BALL VALVES |

METAL SEATED CAST TRUNNION

2" - 24" | Class 150 - Class 600

Materials METAL TO METAL TRUNNION

Item	Description	AIM	IIM
1	Body	A 216 Gr. WCB (C ≤ 0.25%)	A 351 Gr. CF8M
2	Body connector	A 216 Gr. WCB (C ≤ 0.25%)	A 351 Gr. CF8M
3	Ball	A182 F316 or A351Gr. CF8M (Treatments CT-70, CC-60 or HT-65)	
4	Stem	17-4 PH or Nitronic 50	
5	Seat ring	Tp.316 + HT70	
7	Gland nut	Zinc Plated Carbon Steel	AISI-303
8	Disk spring / Spring	Carbon St. *	E.N.P. Carbon St. *
9	Stop plate	Carbon St.	AISI-304
10	Gland ring	AISI-303 + HT-65	AISI-316 + HT-65
10.1	Gland	AISI-303	AISI-316
11	Gland packing	Graphite	
12	Stem thrust seal	AISI-316 + HT-65	
13	Body connector seal	AISI-316L + Graphite	
14	Stop pin	Carbon St.	Stainless St.
15	Stud	A 193 Gr. B7M Zinc dichromate	A 193 Gr. B8M **
18	Thrust washer	50% S.S. PTFE	
19	Antistatic device	Stainless St.	
21 / 21a	Ball trunnion	A 351 Gr. CF8M	
22 / 22a	Trunnion bearing	AISI-316 + PTFE	
26	Bolt	DIN 912 8.8 Zinc Plated	DIN 912 A2
28	Nut	A 194 Gr. 2HM Zinc dichromate	A 194 Gr. 8M **
32	Spring	Inconel - 750	
33	O' Ring	FKM -- Note 1 --	
35	Spring carrier	A 351 Gr. CF8M	
39	Stem bushing	25% G.F. PTFE	
39.1	Stem bushing	AISI-316 + PTFE -- Note 2 & Note 3 --	
41	Spacer	Carbon St.	Stainless St.
43	Key	AISI-316	
46	Locking washer	AISI-304	
47	Key	Carbon St.	
50	Drain plug	A 105	AISI-316
50.1	Vent plug	A 105	AISI-316
52	O' Ring	FKM -- Note 1 & Note 2 --	
54	Seat carrier seal	Graphite	
58	Spring protection	Carbon St.	Stainless St.
72	O' Ring	FKM -- Note 1 --	
75	Stem bushing	AISI-316 + PTFE -- Note 2 & Note 3 --	
89	Identification plate	Stainless St.	
471	Retainer	Carbon St.	Stainless St.

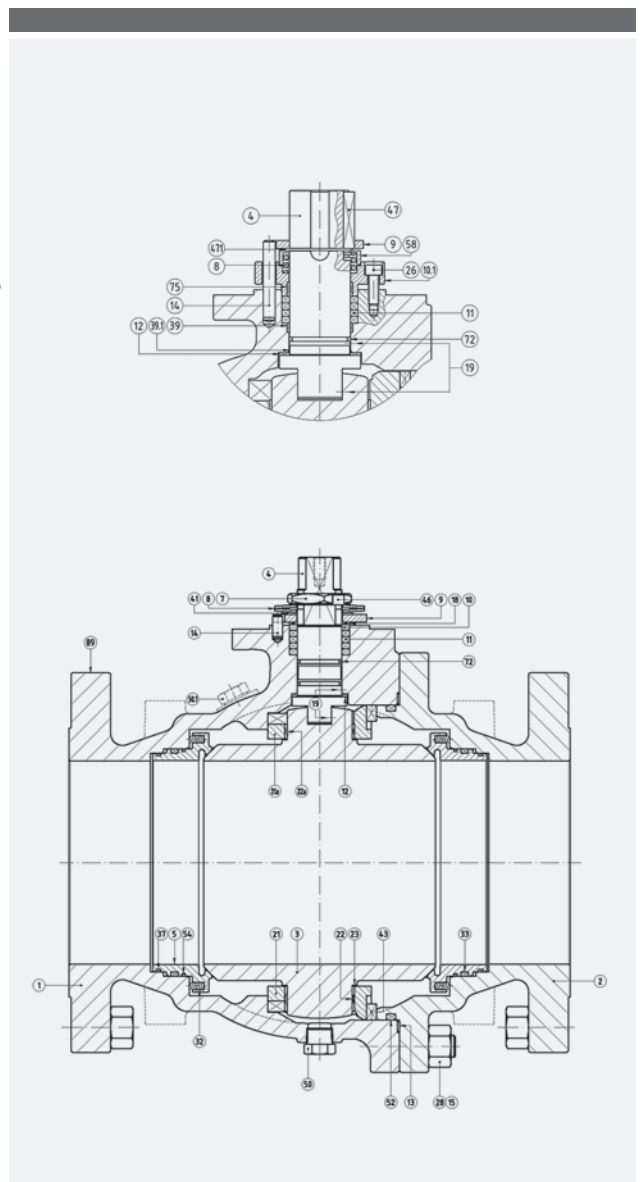

(*) On request Inconel X-750.

(**) On request B7M / 2HM Zinc Plated & Bichromated.

Note 1: Depending on design conditions AFLAS, KALREZ or KALREZ Spectrum.

Note 2: Only DN-350 & 400 and all Fig.2560.

Note 3: Over 350°C Steel Inconel + HT-625

CAST TRUNNION METAL 2515 / 2530 / 2560
Class 150 / 300 / 600
Full Bore
Class 150. From 2" to 16"
Class 300. From 2" to 16"
Class 600. From 2" to 12"

 DN 50 (2") to DN-250 (10") Class-150 & 300
 DN-50 (2") to DN-100 (4") Class-600

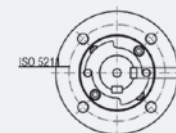
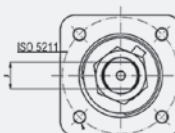
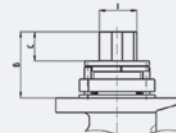
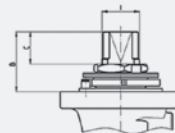
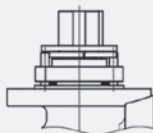
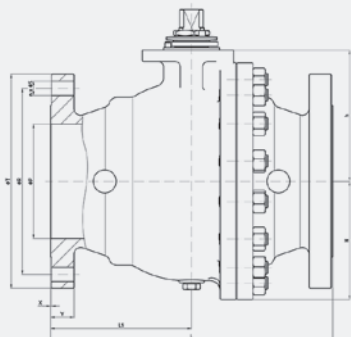
 DN 300 (12") to DN-400 (16") Class-150 & 300
 DN-150 (6") to DN-300 (12") Class-500

(*) Dimensions of diameters of drills ISO 5211 refer to table from page 60.

Pressure - Temperature

P-Bar

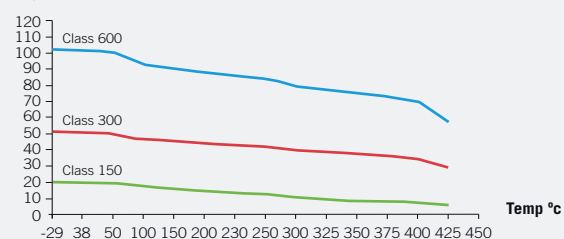
Fig. 2515 (Class 150)

DN	ØP	L	L1	ØR	n x ØS	ØT	h	N	ISO 5211	B	C	I	J	K	WEIGHT	TORQUE
50 (2")	50	178	78.5	120,7	4x19	150	84	80	F07	42	17	M22x1.5	16	-	13	80
80 (3")	80	203	87	152,4	4x19	190	126	-	F10	55	27	M28x1.5	20	-	22	220
100 (4")	100	229	101	190,5	8x19	230	152	120	F12	56	27	M35x2	25	-	39	340
150 (6")	151	394	197	241,3	8x22,2	280	212	168	F14	70	36	M45x2	32	-	98	720
200 (8")	203	457	230	298,5	8x22,2	345	233	208	F14	70	37	M45x2	32	-	124	1.300
250 (10")	254	533	267	362	12x25,4	405	256	243	F14	70	37	M45x2	32	-	175	1.883
300 (12")	305	610	305	431,8	12x25,4	485	297	287,5	F14	106	58	Ø50	14	53,5	295	2.620
350 (14")	337	686	343	476,3	12x28,5	535	333	323	F16	103	49	Ø60	18	64,2	580	2.446
400 (16")	388	762	381	539,8	16x28,5	595	412	358	F25	159	103	Ø90	25	95,3	750	3.160

Fig. 2530 (Class 300)

DN	ØP	L	L1	ØR	n x ØS	ØT	h	N	ISO 5211	B	C	I	J	K	WEIGHT	TORQUE
50 (2")	50	216	84	127	8x19	165	84	-	F07	42	17	M22x1.5	16	-	16	190
80 (3")	80	283	115	168,3	8x22,2	210	126	-	F10	55	27	M28x1.5	20	-	33	360
100 (4")	100	305	133	200	8x22,2	255	152	-	F12	56	27	M35x2	25	-	43	640
150 (6")	151	403	202	269,9	12x22,2	320	212	173	F14	70	36	M45x2	32	-	113	1.290
200 (8")	203	502	252	330,2	12x25,4	380	233	210	F14	70	37	M45x2	32	-	157	2.162
250 (10")	254	568	284	387,4	16x28,5	445	257	253	F14	70	37	M45x2	32	-	263	4.100
300 (12")	305	648	315	450,8	16x31,8	520	310	300	F16	103	49	Ø60	18	64,2	480	5.670
350 (14")	337	762	381	514,4	20x31,8	585	333	331	F16	103	49	Ø60	18	64,2	655	6.030
400 (16")	388	838	419	571,5	20x34,9	650	412	365	F25	159	103	Ø90	25	95,3	890	7.200

Fig. 2560 (Class 600)

DN	ØP	L	L1	ØR	n x ØS	ØT	h	N	ISO 5211	B	C	I	J	K	WEIGHT	TORQUE
50 (2")	50	292	96	127	8x19	165	84	-	F07	42	17	M22x1.5	16	-	20	270
80 (3")	80	356	140	168,3	8x22,2	210	126	113	F10	55	27	M28x1.5	20	-	41	560
100 (4")	100	432	160	215,9	8x25,2	275	152	-	F12	56	27	M35x2	25	-	77	1.240
150 (6")	151	559	246	292,1	12x28,5	355	212	188	F14	97	49	Ø45	14	48,5	192	2.500
200 (8")	203	660	315	349,2	12x31,8	420	237	235	F14	113	64	Ø50	14	53,5	329	6.060
250 (10")	254	787	340	431,8	16x34,9	510	275	273	F16	103	49	Ø60	18	64,2	460	8.300
300 (12")	305	838	404	489	20x34,9	560	345	335	F16	127	73	Ø65	18	69,2	570	9.400

 Dimensions in mm, weight in kg and Torque in Nm.
 Weights and dimensions can be changed without notice.

| BALL VALVES |

METAL SEATED 3-PIECE FORGED TRUNNION MOUNTED

2" - 24" | Class 150 - Class 1500

A trunnion ball valve has additional mechanical anchoring of the ball at the top and the bottom, suitable for larger and higher pressure valves.

The JC trunnion mounted ball valves are suitable to stand the harsh service conditions often presented in the hydrocarbon industry and in the gas storage and transportation field. In general, they are recommended for tight shut-off in high pressure and double block and bleed applications.



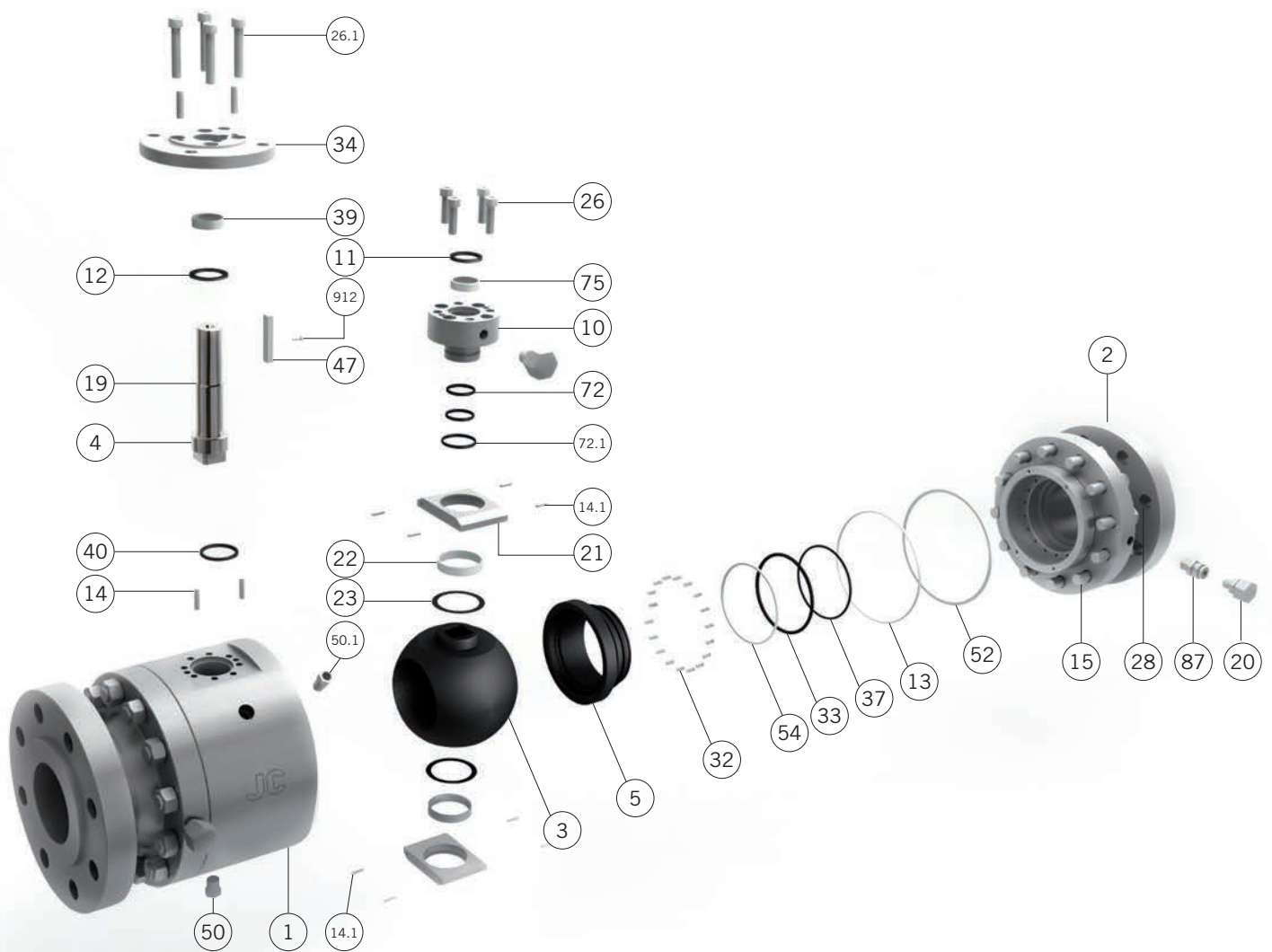

Materials

SERIES 6000(M) & 7000(M)

Item	Description	AIM	LIM	IIM
1	Body	A 105N	A 350 Gr. LF2 Class. 1	A182 F316
2	Body Connector	A 105N	A 350 Gr. LF2 Class. 1	A182 F316
3	Ball		A182 F316 or A351Gr. CF8M (Treatments CT-70, CC-60 or HT-65)	
4	Stem		17-4 PH or Nitronic 50	
5	Seat		A 479 Tp.316 / A182 F316 (Treatments CT-70, CC-60 or HT-65)	
10	Gland	A 105N	A 350 Gr. LF2 Class-1	A 479 Tp.316
11	Gland Packing		Graphite	
12	Stem Thrust Seal		AISI 316 + HT-65	
13	Body Connector Seal		Graphite	
14 / 14.1	Pin	Carbon St.	Carbon Steel	Stainless Steel
15	Stud	A 193 Gr. B7M Zinc dichromate	A 320 Gr. L7M	A 193 Gr. B8M
19	Antistatic Device		Stainless St.	
20	Sealant Injector	Carbon Steel	Carbon Steel	Stainless Steel
21	Ball Trunnion		A 479 Tp.316	
22*	Trunnion Bearing		AISI 316 with inside in PTFE	
23*	Bearing		PTFE	
26 / 26.1	Bolt	A 193 Gr. B7M Zinc dichromate	A 320 Gr. L7M	A 193 Gr. B8M
28	Nut	A 194 Gr. 2HM Zinc dichromate	A 194 Gr. 7M	A 194 Gr. 8M
32	Spring		Inconel - 750	
33*	"O" Ring		AFLAS	
34	Mounting Flange	A 105N	A 350 Gr. LF2 Class-1	A 479 Tp.316
37*	"O" Ring		AFLAS	
39*	Stem Bushing		AISI 316 with inside in PTFE	
40	Gasket		Graphite	
47	Key	Carbon Steel	Carbon Steel	Stainless St.
50	Drain Plug	A 105	A 350 Gr. LF2 Class-1	AISI 316
50.1	Relieve Plug	A 105	A 350 Gr. LF2 Class-1	AISI 316
52*	"O" Ring		AFLAS	
54	Seat Carrier Seal		Graphite	
72* / 72.1	"O" Ring		AFLAS	
75*	Stem Bushing		AISI 316 with inside in PTFE	
87	Check Valve		Stainless St.	
912	Bolt		DIN 912 A2	

(*) In case of extreme high temperature it could be changed to another material.

METAL SEATED FORGED BALL VALVES 6015 / 6030 / 6060 / 6090 / 6050

Full Bore

Class 150.
From 2" to 24" (1)

Class 300.
From 2" to 24" (1)

Class 600.
From 2" to 24" (1)

Class 900.
From 2" to 12" (1)

Class 1500.
From 2" to 8" (1)

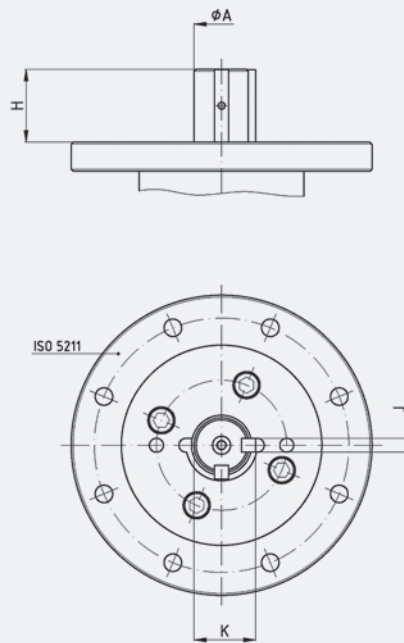
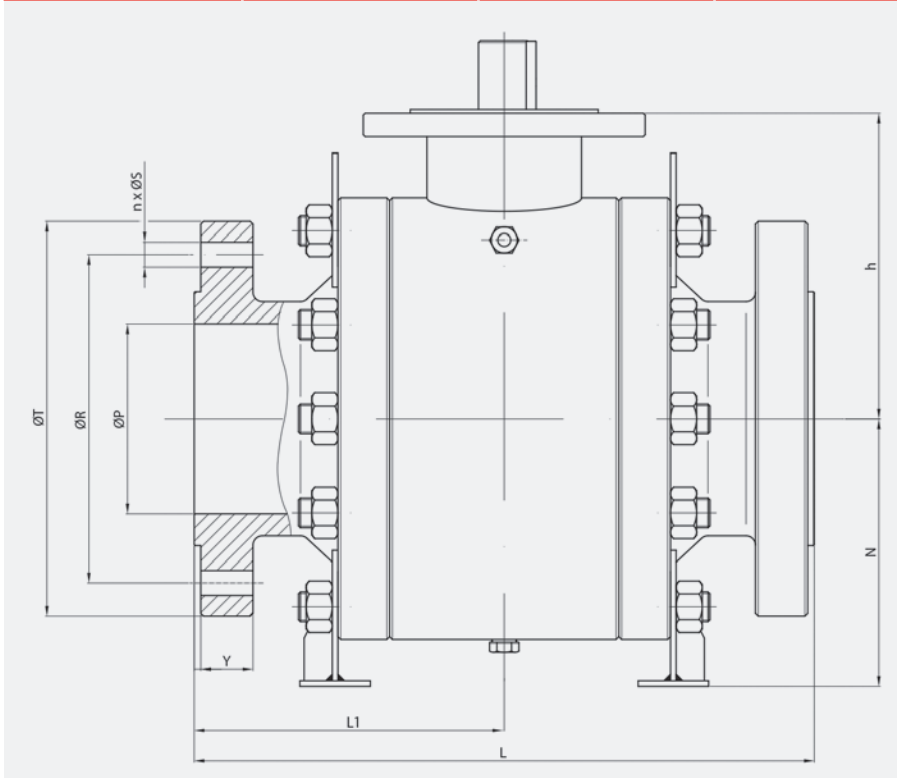

(*) Dimensions of diameters of drills ISO 5211 refer to table from page 60.

Pressure - Temperature

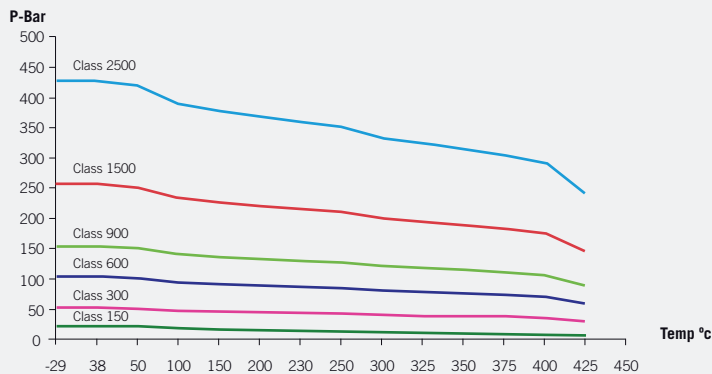

Fig. 6015 (Class 150)

DN	øP	L	L1	øR	n x øS	øT	Y	h	N	ISO 5211	H	øA	J	K	WEIGHT	TORQUE	Kv
2"	49	178	89	120,7	4x19,1	150	14,3	131,5	100	F10	30	19,9	8	22,5	24	92	366
3"	76	203	101,5	152,4	4x19,1	190	17,5	163	134	F12	31	26	10	30	47	197	938
4"	100	229	108,3	190,5	8x19,1	230	22,3	181,5	167	F12	47,5	29,9	10	34	86	332	1.465
6"	152	394	197	241,3	8x22,2	280	23,9	278	277	F16	61,5	39,9	14	48,9	191	582	3.297
8"	203	457	228,5	298,5	8x22,2	345	27	334,5	325	F25	67,5	49,9	14	58,4	357	907	5.861
10"	254	533	266,5	362	12x25,4	405	28,6	371	319	F25	75	59,9	2 x 16	67	529	1.569	9.454
12"	305	610	305	431,8	12x25,4	485	30,2	432,5	399	F25	94,5	69,9	2 x 18	78	794	1.945	13.631
14"	337	686	343	476,3	12x28,6	535	33,4	464,5	439	F30	109,5	79,9	2 x 22	87,9	1.120	3.303	16.641
16"	387	762	381	539,8	16x28,6	595	35	499,5	462	F30	121,5	84,9	2 x 22	94,9	1.473	4.451	23.554
18"	436	864	432	577,9	16x31,8	635	38,1	551,5	584	F30	138	99,9	2 x 28	111,9	1.860	6.006	29.672
20"	488	914	457	635	20x31,8	700	41,3	586,5	543	F30	138	99,9	2 x 28	111,9	2.589	7.506	36.633
24"	589	1.067	533,5	749,3	20x34,9	815	46,1	684	674	F35	153,5	120	32	134	4.302	14.503	52.751

Dimensions in mm, weight in kg and Torque in Nm.
Weights and dimensions can be changed without notice.
(1) Bigger sizes available under customers request.

Fig. 6030 (Class 300)

DN	øP	L	L1	øR	n x øS	øT	Y	h	N	ISO 5211	H	øA	J	K	WEIGHT	TORQUE	Kv
2"	49	216	108	127	8x19,1	165	20,7	131,5	100	F10	30	19,9	8	22,5	28	125	366
3"	76	283	141,5	168,3	8x22,2	210	27	163	134	F12	31	26	10	30	61	282	938
4"	100	305	152,5	200	8x22,2	255	30,2	181,5	167	F12	47,5	29,9	10	34	100	460	1.465
6"	152	403	201,5	269,9	12x22,2	320	35	278	277	F16	61,5	39,9	14	48,9	217	927	3.297
8"	203	502	251	330,2	12x25,4	380	39,7	334,5	293	F25	67,5	49,9	14	58,4	387	1.540	5.861
10"	254	568	284	387,4	16x28,6	445	46,1	371	335	F25	75	59,9	2 x 16	67	610	1.887	9.454
12"	305	648	324	450,8	16x31,8	520	49,3	432,5	386	F25	94,5	69,9	2 x 18	78	882	2.488	13.631
14"	337	762	381	514,4	20x31,8	585	52,4	464,5	430	F30	109,5	79,9	2 x 22	87,9	1.296	4.398	16.641
16"	387	838	419	571,5	20x34,9	650	55,6	499,5	472	F30	121,5	84,9	2 x 22	94,9	1.687	5.890	23.554
18"	436	914	457	628,6	24x34,9	710	58,8	551,5	596	F30	138	99,9	2 x 28	111,9	2.057	8.577	29.672
20"	488	991	495,5	685,8	24x34,9	775	62	586,5	610	F30	138	99,9	2 x 28	111,9	2.872	11.389	36.633
24"	589	1.143	571,5	812,8	24x41,3	915	68,3	684	674	F35	153,5	120	32	134	5.525	20.170	52.751

Fig. 6060 (Class 600)

DN	øP	L	L1	øR	n x øS	øT	Y	h	N	ISO 5211	H	øA	J	K	WEIGHT	TORQUE	Kv
2"	49	292	146	127	8x19,1	165	25,4	131,5	100	F10	30	19,9	8	22,5	33	198	366
3"	76	356	178	168,3	8x22,2	210	31,8	163	139	F12	31	26	10	30	75	413	938
4"	100	432	216	215,9	8x25,4	275	38,1	181,5	164	F12	47,5	29,9	10	34	136	613	1.465
6"	152	559	279,5	292,1	12x28,6	355	47,7	278	278	F16	61,5	44,9	14	51,4	300	1.366	3.297
8"	203	660	330	349,2	12x31,8	420	55,6	334,5	296	F25	67,5	54,9	14	61,4	561	3.431	5.861
10"	254	787	393,5	431,8	16x34,9	510	63,5	371	365	F25	75	59,9	2 x 16	67	828	4.360	9.454
12"	305	838	419	489	20x34,9	560	66,7	432,5	419	F25	94	69,9	2 x 18	78	1.238	5.743	13.631
14"	337	889	444,5	527	20x38,1	605	69,9	464,5	450	F30	109,5	79,9	2 x 22	87,9	1.532	6.773	16.641
16"	387	991	495,5	603,2	20x41,3	685	76,2	499,5	505	F30	121,5	84,9	2 x 22	94,9	2.137	8.510	23.554
18"	436	1.092	546	654	20x44,5	745	82,6	551,5	568	F30	138	99,9	2 x 28	111,9	2.595	13.837	29.672
20"	488	1.194	597	723,9	24x44,5	815	88,9	586,5	581	F35	138	99,9	2 x 28	111,9	3.454	19.049	36.633
24"	589	1.397	698,5	838,2	24x50,8	940	101,6	684	758	F35	153,5	120	32	134	6.250	27.994	52.751

Fig. 6090 (Class 900)

DN	øP	L	L1	øR	n x øS	øT	Y	h	N	ISO 5211	H	øA	J	K	WEIGHT	TORQUE	Kv
2"	49	368	184	165,1	8x25,4	215	38,1	161	124	F14	46	29	8	32,5	52	315	366
3"	74	381	190,5	190,5	8x25,4	240	38,1	204	153	F16	50	39,9	10	44,5	80	547	938
4"	102	457	228,5	235	8x31,8	290	44,5	236,7	211	F25	55,5	39,9	10	44,5	170	857	1.465
6"	152	610	305	317,5	12x31,8	380	55,6	277	287	F25	62,5	44,9	14	51,4	390	1.874	3.297
8"	203	737	368,5	393,7	12x38,1	470	63,5	345	299	F25	86,5	65	2 x 16	74,5	640	4.294	5.861
10"	254	838	419	469,9	16x38,1	545	69,9	402	377	F25	90	75	2 x 20	81	1.070	5.446	9.454
12"	303	965	482,5	533,4	20x38,1	610	79,4	432	420	F25	99	85	22	95	1.610	6.768	13.631

Fig. 6050 (Class 1500)

DN	øP	L	L1	øR	n x øS	øT	Y	h	N	ISO 5211	H	øA	J	K	WEIGHT	TORQUE	Kv
2"	49	368	184	165,1	8x25,4	215	38,1	161	124	F14	46	29	8	32,5	55	448	336
3"	74	470	235	203,2	8x31,8	265	47,7	214,5	163	F25	54,5	39,9	10	44,5	105	1.048	938
4"	102	546	273	241,3	8x34,9	310	54	236,7	213	F25	55,5	39,9	10	44,5	205	1.619	1.465
6"	146	705	352,5	317,5	12x38,1	395	82,6	324	321	F25	95	60	18	64	525	3.980	3.297
8"	194	832	416	393,7	12x44,5	485	92,1	410,5	323	F25	118,5	75	18	82,9	890	6.200	5.861

Dimensions in mm, weight in kg and Torque in Nm.
Weights and dimensions can be changed without notice.
(1) Bigger sizes available under customers request.

METAL SEATED FORGED BALL VALVES 7015 / 7030 / 7060 / 7090 / 7050

Reduced Bore

Class 150.
From 2" to 24" (1)

Class 300.
From 2" to 24" (1)

Class 600.
From 2" to 24" (1)

Class 900.
From 2" to 12" (1)

Class 1500.
From 2" to 8" (1)

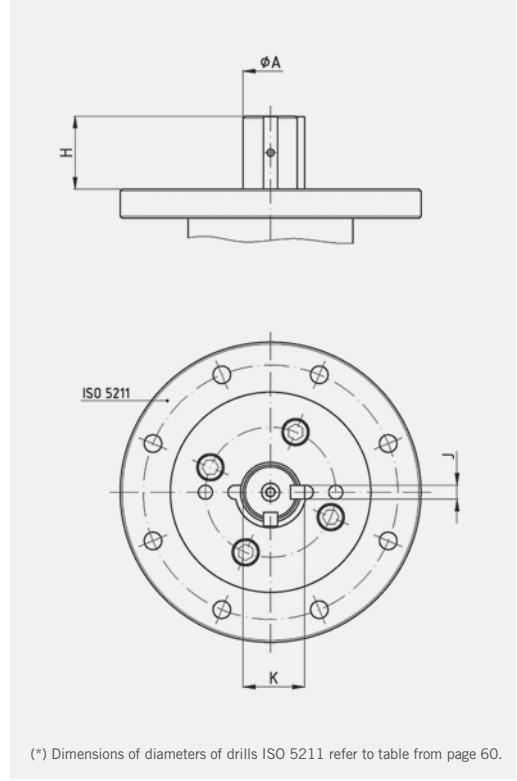
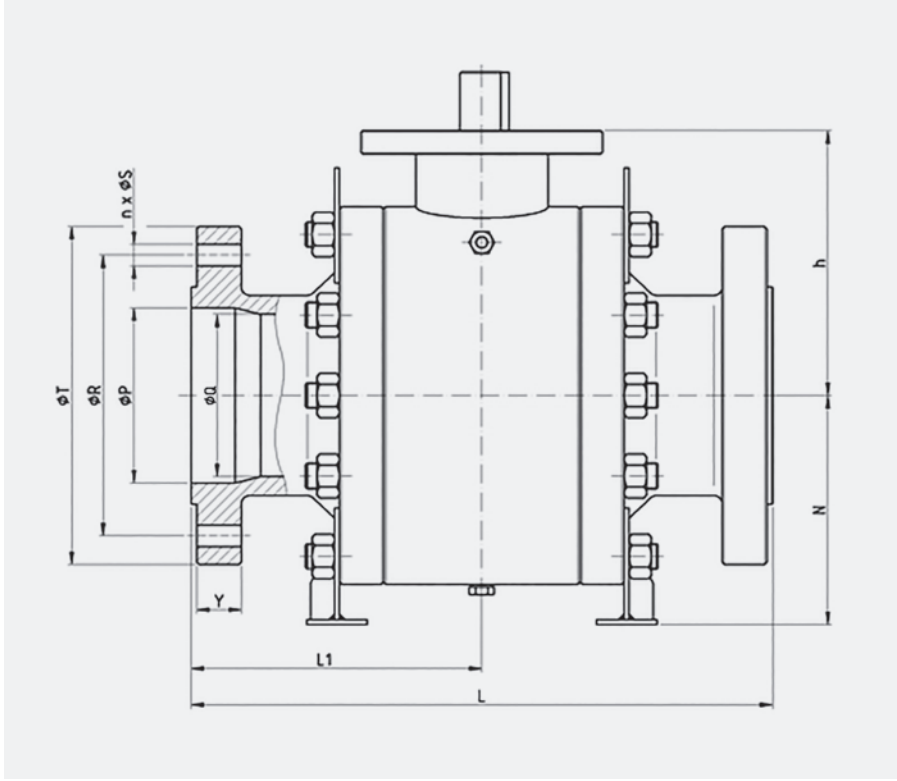

(*) Dimensions of diameters of drills ISO 5211 refer to table from page 60.

Pressure - Temperature

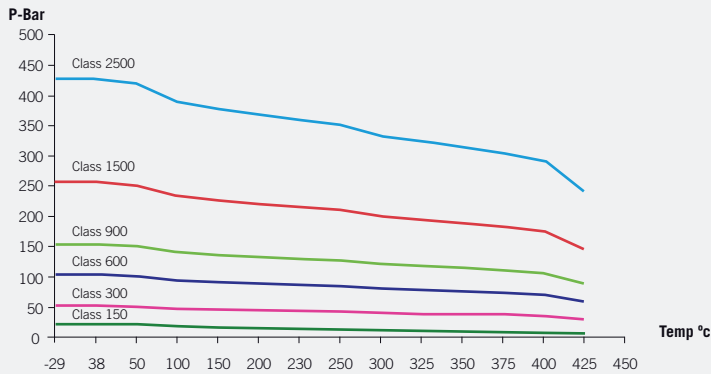

Fig. 7015 (Class 150)

DN	øP	øQ	L	L1	øR	n x øS	øT	Y	h	N	ISO 5211	H	øA	J	K	WEIGHT	TORQUE	Kv
3" x 2"	76	49	203	101,5	152,4	4x19,1	190	17,5	131,5	100	F10	30	19,9	8	22,5	66	92	190
4" x 3"	100	76	229	108,3	190,5	8x19,1	230	22,3	163	134	F12	31	26	10	30	75	197	567
6" x 4"	152	100	394	197	241,3	8x22,2	280	23,9	181,5	167	F12	47,5	29,9	10	34	115	332	815
8" x 6"	203	152	457	228,5	298,5	8x22,2	345	27	278	277	F16	61,5	39,9	14	48,9	205	582	2.021
10" x 8"	254	203	533	266,5	362	12x25,4	405	28,6	334,5	325	F25	67,5	49,9	14	58,4	375	907	4.205
12" x 10"	305	254	610	305	431,8	12x25,4	485	30,2	371	319	F25	75	59,9	2 x 16	67	565	1.569	7.348
14" x 12"	337	305	686	343	476,3	12x28,6	535	33,4	432,5	399	F25	94,5	69,9	2 x 18	78	825	1.945	10.120
16" x 14"	387	337	762	381	539,8	16x28,6	595	35	464,5	439	F30	109,5	79,9	2 x 22	87,9	1.250	3.303	12.000
18" x 16"	436	387	864	432	577,9	16x31,8	635	38,1	499,5	462	F30	121,5	84,9	2 x 22	94,9	1.820	4.451	17.269
20" x 18"	488	436	914	457	635	20x31,8	700	41,3	551,5	584	F30	138	99,9	2 x 28	111,9	2.450	6.006	18.647
24" x 20"	589	488	1.067	533,5	749,3	20x34,9	815	46,1	586,5	543	F30	138	99,9	2 x 28	111,9	2.790	7.506	27.010
30" x 24"	735	589	1.295	647,5	857	28x34,9	985	73	684	674	F35	153,5	120	32	134	5.530	14.503	32.150

Dimensions in mm, weight in kg and Torque in Nm.
Weights and dimensions can be changed without notice.
(1) Bigger sizes available under customers request.

Fig. 7030 (Class 300)

DN	øP	øS	L	L1	øR	n x øS	øT	Y	h	N	ISO 5211	H	øA	J	K	WEIGHT	TORQUE	Kv
3" x 2"	76	49	283	141,5	168,3	8x22,2	210	27	131,5	100	F10	30	19,9	8	22,5	65	125	190
4" x 3"	100	76	305	152,5	200	8x22,2	255	30,2	163	134	F12	31	26	10	30	85	282	567
6" x 4"	152	100	403	201,5	269,9	12x22,2	320	35	181,5	167	F12	47,5	29,9	10	34	135	460	815
8" x 6"	203	152	502	251	330,2	12x25,4	380	39,7	278	277	F16	61,5	39,9	14	48,9	225	927	2.021
10" x 8"	254	203	568	284	387,4	16x28,6	445	46,1	334,5	293	F25	67,5	49,9	14	58,4	385	1.540	4.205
12" x 10"	305	254	648	324	450,8	16x31,8	520	49,3	371	335	F25	75	59,9	2 x 16	67	650	1.887	7.348
14" x 12"	337	305	762	381	514,4	20x31,8	585	52,4	432,5	386	F25	94,5	69,9	2 x 18	78	995	2.488	10.120
16" x 14"	387	337	838	419	571,5	20x34,9	650	55,6	464,5	430	F30	109,5	79,9	2 x 22	87,9	1.460	4.398	12.000
18" x 16"	436	387	914	457	628,6	24x34,9	710	58,8	499,5	472	F30	121,5	84,9	2 x 22	94,9	1.925	5.890	17.269
20" x 18"	488	436	991	495,5	685,8	24x34,9	775	62	551,5	596	F30	138	99,9	2 x 28	111,9	2.450	8.577	18.647
24" x 20"	589	488	1.143	571,5	812,8	24x41,3	915	68,3	586,5	610	F30	138	99,9	2 x 28	111,9	3.250	11.389	27.010
30" x 24"	735	589	1.397	698,5	857	28x48	1.092	90	684	674	F35	153,5	120	32	134	5.900	20.170	32.150

Fig. 7060 (Class 600)

DN	øP	øS	L	L1	øR	n x øS	øT	Y	h	N	ISO 5211	H	øA	J	K	WEIGHT	TORQUE	Kv
3" x 2"	76	49	356	178	168,3	8x22,2	210	31,8	131,5	100	F10	30	19,9	8	22,5	72	198	190
4" x 3"	100	76	432	216	215,9	8x25,4	275	38,1	163	139	F12	31	26	10	30	93	413	567
6" x 4"	152	100	559	279,5	292,1	12x28,6	355	47,7	181,5	164	F12	47,5	29,9	10	34	169	613	815
8" x 6"	203	152	660	330	349,2	12x31,8	420	55,6	278	278	F16	61,5	44,9	14	51,4	301	1.366	2.021
10" x 8"	254	203	787	393,5	431,8	16x34,9	510	63,5	334,5	296	F25	67,5	54,9	14	61,4	555	3.431	4.205
12" x 10"	305	254	838	419	489	20x34,9	560	66,7	371	365	F25	75	59,9	2 x 16	67	829	4.360	7.348
14" x 12"	337	305	889	444,5	527	20x38,1	605	69,9	432,5	419	F25	94	69,9	2 x 18	78	1.426	5.743	10.120
16" x 14"	387	337	991	495,5	603,2	20x41,3	685	76,2	464,5	450	F30	109,5	79,9	2 x 22	87,9	1.751	6.773	12.000
18" x 16"	436	387	1.092	546	654	20x44,5	745	82,6	499,5	505	F30	121,5	84,9	2 x 22	94,9	2.625	8.510	17.269
20" x 18"	488	436	1.194	597	723,9	24x44,5	815	88,9	551,5	568	F30	138	99,9	2 x 28	111,9	3.111	13.837	18.647
24" x 20"	589	488	1.397	698,5	838,2	24x50,8	940	101,6	586,5	581	F35	138	99,9	2 x 28	111,9	4.250	19.049	27.010
30" x 24"	735	589	1.651	825,5	857	28x54	1.130	108	684	758	F35	153,5	120	32	134	7.125	27.994	32.150

Fig. 7090 (Class 900)

DN	øP	øS	L	L1	øR	n x øS	øT	Y	h	N	ISO 5211	H	øA	J	K	WEIGHT	TORQUE	Kv
3" x 2"	76	49	381	190,5	190,5	8x25,4	240	38,1	161	124	F14	46	29	8	32,5	62	315	190
4" x 3"	100	76	457	228,5	235	8x31,8	290	44,5	204	153	F16	50	39,9	10	44,5	105	547	567
6" x 4"	152	100	610	305	317,5	12x31,8	380	55,6	236,7	211	F25	55,5	39,9	10	44,5	201	857	815
8" x 6"	203	152	737	368,5	393,7	12x38,1	470	63,5	277	287	F25	62,5	44,9	14	51,4	436	1.874	2.021
10" x 8"	254	203	838	419	469,9	16x38,1	545	69,9	345	299	F25	86,5	65	2 x 16	74,5	735	4.294	4.205
12" x 10"	305	254	965	482,5	533,4	20x38,1	610	79,4	402	377	F25	90	75	2 x 20	81	1.200	5.446	7.348
14" x 12"	337	305	1.029	514,5	558,8	20x41,3	640	85,8	432	420	F25	99	85	22	95	1.795	6.768	10.120

Fig. 7050 (Class 1500)

DN	øP	øS	L	L1	øR	n x øS	øT	Y	h	N	ISO 5211	H	øA	J	K	WEIGHT	TORQUE	Kv
3" x 2"	74	49	470	235	203,2	8x31,8	265	47,7	161	124	F14	46	29	8	32,5	80	448	190
4" x 3"	102	74	546	273	241,3	8x34,9	310	54	214,5	163	F25	54,5	39,9	10	44,5	156	1.048	567
6" x 4"	146	102	705	352,5	317,5	12x38,1	395	82,6	236,7	213	F25	55,5	39,9	10	44,5	325	1.619	815
8" x 6"	194	146	832	416	393,7	12x44,5	485	92,1	324	321	F25	95	60	18	64	603	3.980	2.021
10" x 8"	241	194	991	495,5	482,6	12x50,8	585	108	410,5	323	F25	118,5	75	18	82,9	950	6.200	4.205

Dimensions in mm, weight in kg and Torque in Nm.
Weights and dimensions can be changed without notice.
(1) Bigger sizes available under customers request.

| BALL VALVES |

3-PIECE FORGED TRUNNION MOUNTED

2" - 42" | Class 150 - Class 2500

A trunnion ball valve has additional mechanical anchoring of the ball at the top and the bottom, suitable for larger and higher pressure valves.

The JC trunnion mounted ball valves are suitable to stand the harsh service conditions often presented in the hydrocarbon industry and in the gas storage and transportation field. In general, they are recommended for tight shut-off in high pressure and double block and bleed applications.

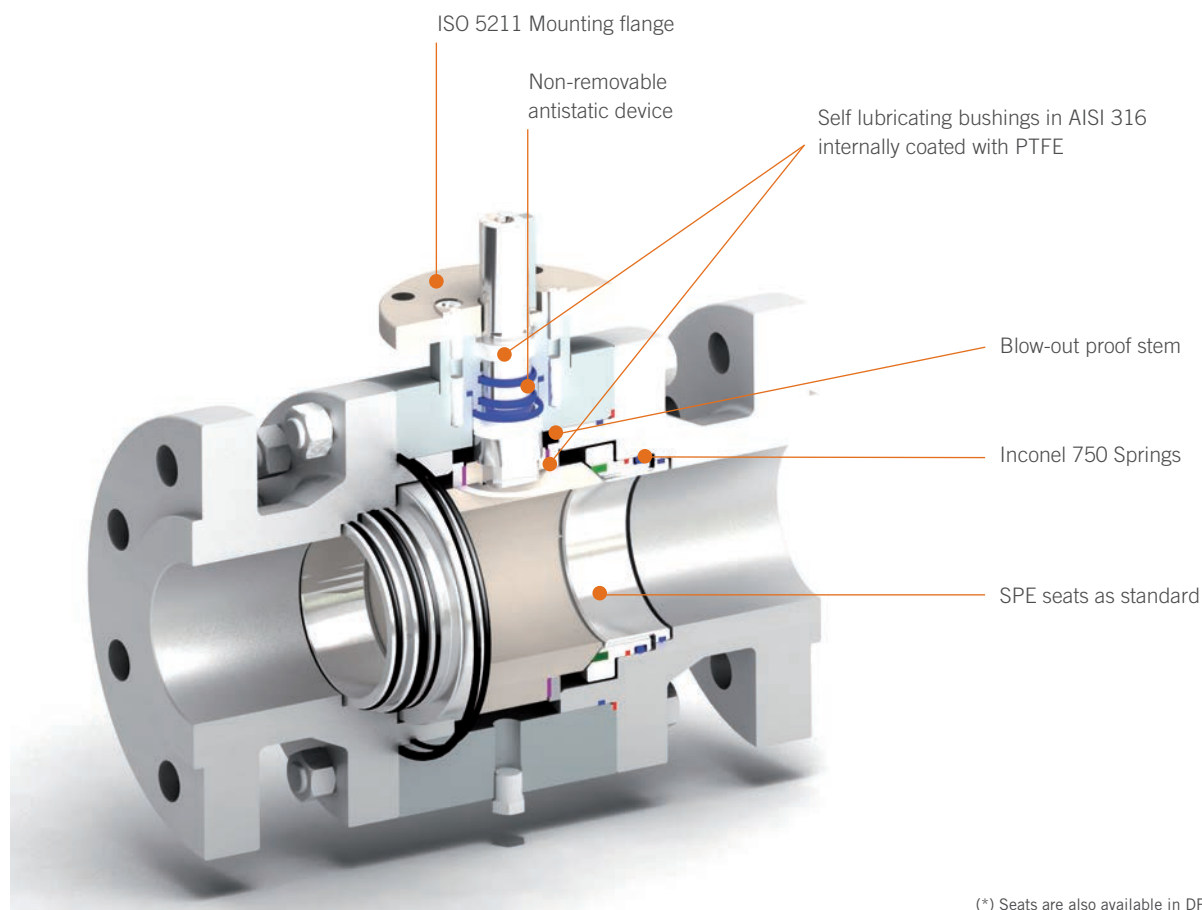

(*) Seats are also available in DPE (Double Piston Effect) and PMSS (Primary Metal, Secondary Soft).

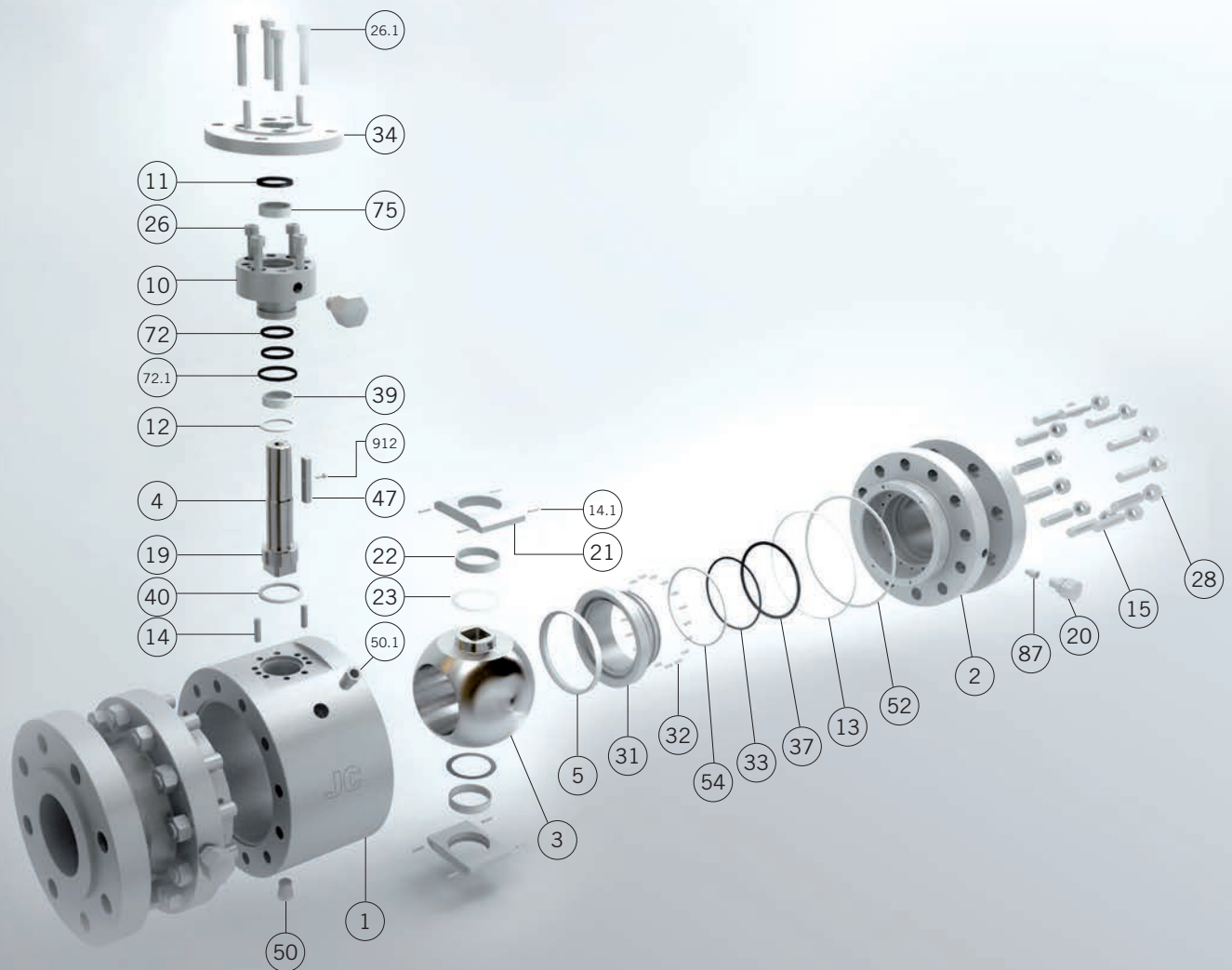

Materials

SERIES 6000 & 7000

Item	Description	AIT	LIT	IIT
1	Body	A 105N	A 350 Gr. LF2 Class. 1	A182 F316
2	Body Connector	A 105N	A 350 Gr. LF2 Class. 1	A182 F316
3	Ball		A 182 F316 or A351 Gr. CF8M / A105+ENP	
4	Stem		A 479 Tp.316	
5	Seat Ring		RPTFE, PEEK, DEVLON	
10	Gland	A 105N	A 350 Gr. LF2 Class-1	A 479 Tp.316
11	Gland Packing		Graphite	
12	Stem Thrust Seal		25% G.F. + PTFE	
13	Body Connector Seal		Graphite	
14 / 14.1	Pin	Carbon St.	Carbon Steel	Stainless Steel
15	Stud	A 193 Gr. B7M Zinc dichromate	A 320 Gr. L7M	A 193 Gr. B8M
19	Antistatic Device		Stainless St.	
20	Sealant Injector	Carbon Steel	Carbon Steel	Stainless Steel
21	Ball Trunnion		A 479 Tp.316	
22	Trunnion Bearing		AISI 316 with inside in PTFE	
23	Bearing		PTFE	
26 / 26.1	Bolt	A 193 Gr. B7M Zinc dichromate	A 320 Gr. L7M	A 193 Gr. B8M
28	Nut	A 194 Gr. 2HM Zinc dichromate	A 194 Gr. 7M	A 194 Gr. 8M
31	Seat Carrier		A 479 Tp.316 / A182 F316	
32	Spring		Inconel - 750	
33	"O" Ring		FKM	
34	Mounting Flange	A 105N	A 350 Gr. LF2 Class-1	A 479 Tp.316
37	"O" Ring		FKM	
39	Stem Bushing		AISI 316 with inside in PTFE	
40	Gasket		Graphite	
47	Key	Carbon Steel	Carbon Steel	Stainless St.
50	Drain Plug	A 105	A 350 Gr. LF2 Class-1	AISI 316
50.1	Relief Plug	A 105	A 350 Gr. LF2 Class-1	AISI 316
52	"O" Ring		FKM	
54	Seat Carrier Seal		Graphite	
72 / 72.1	"O" Ring		FKM	
75	Stem Bushing		AISI 316 with inside in PTFE	
87	Check Valve		Stainless St.	
912	Bolt		DIN 912 A2	

FORGED BALL VALVES 6015 / 6030 / 6060 / 6090 / 6050 / 6042

Full Bore

Class 150.
From 2" to 42"

Class 300.
From 2" to 42"

Class 600.
From 2" to 24"

Class 900.
From 2" to 24"

Class 1500.
From 2" to 12"

Class 2500.
From 2" to 8"

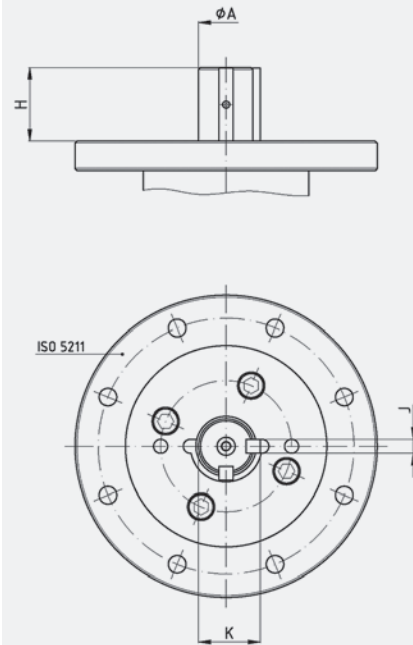
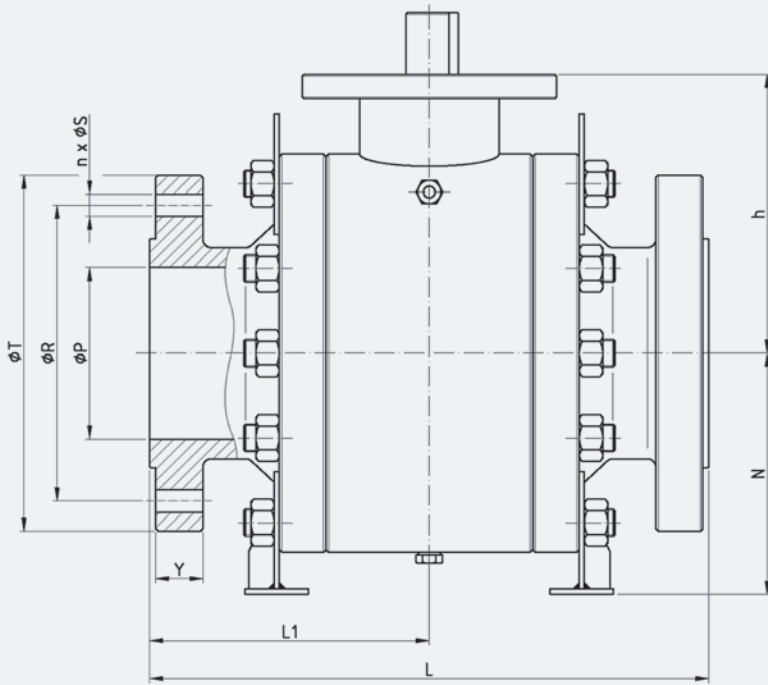

(*) Dimensions of diameters of drills ISO 5211 refer to table on page 60.

Pressure - Temperature

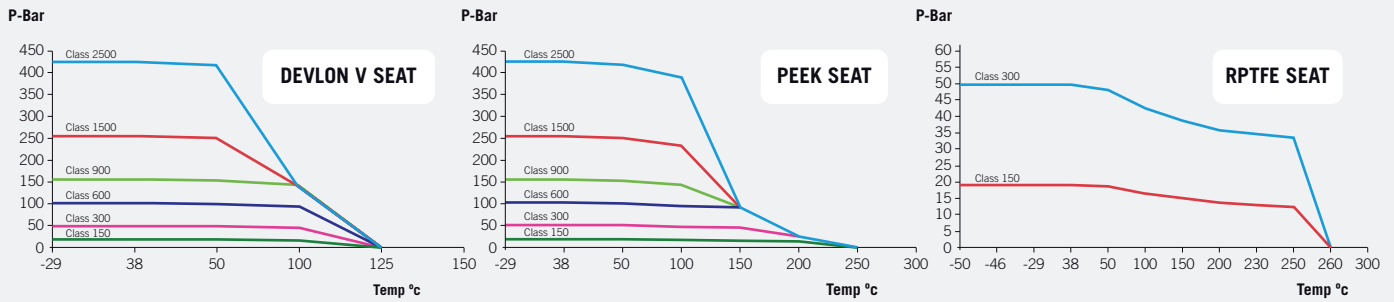

Fig. 6015 (Class 150)

DN	ØP	L	L1	ØR	n x ØS	ØT	Y	h	N	ISO 5211	H	ØA	J	K	WEIGHT	TORQUE	Kv
2"	49	178	89	120,7	4x19,1	150	14,3	131,5	100	F10	30	19,9	8	22,5	24	62	366
3"	76	203	101,5	152,4	4x19,1	190	17,5	163	134	F12	31	26	10	30	47	130	938
4"	100	229	108,3	190,5	8x19,1	230	22,3	181,5	167	F12	47,5	29,9	10	34	86	219	1.465
6"	152	394	197	241,3	8x22,2	280	23,9	278	277	F16	61,5	39,9	14	48,9	191	351	3.297
8"	203	457	228,5	298,5	8x22,2	345	27	334,5	325	F25	67,5	49,9	14	58,4	357	648	5.861
10"	254	533	266,5	362	12x25,4	405	28,6	371	319	F25	75	59,9	2 x 16	67	529	805	9.454
12"	305	610	305	431,8	12x25,4	485	30,2	432,5	399	F25	94,5	69,9	2 x 18	78	794	997	13.631
14"	337	686	343	476,3	12x28,6	535	33,4	464,5	439	F30	109,5	79,9	2 x 22	87,9	1.120	2.258	16.641
16"	387	762	381	539,8	16x28,6	595	35	499,5	462	F30	121,5	84,9	2 x 22	94,9	1.473	3.120	23.554
18"	436	864	432	577,9	16x31,8	635	38,1	551,5	584	F30	138	99,9	2 x 28	111,9	1.860	4.107	29.672
20"	488	914	457	635	20x31,8	700	41,3	586,5	543	F30	138	99,9	2 x 28	111,9	2.589	5.133	36.633
24"	589	1.067	533,5	749,3	20x34,9	815	46,1	684	674	F35	153,5	120	32	134	4.302	10.536	52.751

Dimensions in mm, weight in kg and Torque in Nm.
Weights and dimensions can be changed without notice.

Torque value given:
6015/6030 till 12" seats in RPTFE, from 14" seats in Devlon.
6060/6090/6050/6042 seats in Devlon.

Fig. 6030 (Class 300)

DN	øP	L	L1	øR	n x øS	øT	Y	h	N	ISO 5211	H	øA	J	K	WEIGHT	TORQUE	Kv
2"	49	216	108	127	8x19,1	165	20,7	131,5	100	F10	30	19,9	8	22,5	28	71	366
3"	76	283	141,5	168,3	8x22,2	210	27	163	134	F12	31	26	10	30	61	154	938
4"	100	305	152,5	200	8x22,2	255	30,2	181,5	167	F12	47,5	29,9	10	34	100	265	1.465
6"	152	403	201,5	269,9	12x22,2	320	35	278	277	F16	61,5	39,9	14	48,9	217	504	3.297
8"	203	502	251	330,2	12x25,4	380	39,7	334,5	293	F25	67,5	49,9	14	58,4	387	1.100	5.861
10"	254	568	284	387,4	16x28,6	445	46,1	371	335	F25	75	59,9	2 x 16	67	610	1.334	9.454
12"	305	648	324	450,8	16x31,8	520	49,3	432,5	386	F25	94,5	69,9	2 x 18	78	882	1.741	13.631
14"	337	762	381	514,4	20x31,8	585	52,4	464,5	430	F30	109,5	79,9	2 x 22	87,9	1.296	3.383	16.641
16"	387	838	419	571,5	20x34,9	650	55,6	499,5	472	F30	121,5	84,9	2 x 22	94,9	1.687	4.531	23.554
18"	436	914	457	628,6	24x34,9	710	58,8	551,5	596	F30	138	99,9	2 x 28	111,9	2.057	6.598	29.672
20"	488	991	495,5	685,8	24x34,9	775	62	586,5	610	F30	138	99,9	2 x 28	111,9	2.872	8.761	36.633
24"	589	1.143	571,5	812,8	24x41,3	915	68,3	684	674	F35	153,5	120	32	134	5.525	15.516	52.751

Fig. 6060 (Class 600)

DN	øP	L	L1	øR	n x øS	øT	Y	h	N	ISO 5211	H	øA	J	K	WEIGHT	TORQUE	Kv
2"	49	292	146	127	8x19,1	165	25,4	131,5	100	F10	30	19,9	8	22,5	33	151	366
3"	76	356	178	168,3	8x22,2	210	31,8	163	139	F12	31	26	10	30	75	318	938
4"	100	432	216	215,9	8x25,4	275	38,1	181,5	164	F12	47,5	29,9	10	34	136	469	1.465
6"	152	559	279,5	292,1	12x28,6	355	47,7	278	278	F16	61,5	44,9	14	51,4	300	1.044	3.297
8"	203	660	330	349,2	12x31,8	420	55,6	334,5	296	F25	67,5	54,9	14	61,4	561	2.629	5.861
10"	254	787	393,5	431,8	16x34,9	510	63,5	371	365	F25	75	59,9	2 x 16	67	828	3.366	9.454
12"	305	838	419	489	20x34,9	560	66,7	432,5	419	F25	94	69,9	2 x 18	78	1.238	4.403	13.631
14"	337	889	444,5	527	20x38,1	605	69,9	464,5	450	F30	109,5	79,9	2 x 22	87,9	1.532	5.210	16.641
16"	387	991	495,5	603,2	20x41,3	685	76,2	499,5	505	F30	121,5	84,9	2 x 22	94,9	2.137	6.513	23.554
18"	436	1.092	546	654	20x44,5	745	82,6	551,5	568	F30	138	99,9	2 x 28	111,9	2.595	10.644	29.672
20"	488	1.194	597	723,9	24x44,5	815	88,9	586,5	581	F35	138	99,9	2 x 28	111,9	3.454	14.653	36.633
24"	589	1.397	698,5	838,2	24x50,8	940	101,6	684	758	F35	153,5	120	32	134	6.250	21.533	52.751

Fig. 6090 (Class 900)

DN	øP	L	L1	øR	n x øS	øT	Y	h	N	ISO 5211	H	øA	J	K	WEIGHT	TORQUE	Kv
2"	49	368	184	165,1	8x25,4	215	38,1	161	124	F14	46	29	8	32,5	52	239	366
3"	74	381	190,5	190,5	8x25,4	240	38,1	204	153	F16	50	39,9	10	44,5	80	421	938
4"	102	457	228,5	235	8x31,8	290	44,5	236,7	211	F25	55,5	39,9	10	44,5	170	659	1.465
6"	152	610	305	317,5	12x31,8	380	55,6	277	287	F25	62,5	44,9	14	51,4	390	1.433	3.297
8"	203	737	368,5	393,7	12x38,1	470	63,5	345	299	F25	86,5	65	2 x 16	74,5	640	3.263	5.861
10"	254	838	419	469,9	16x38,1	545	69,9	402	377	F25	90	75	2 x 20	81	1.070	4.139	9.454
12"	303	965	482,5	533,4	20x38,1	610	79,4	432	420	F25	99	85	22	95	1.610	5.218	13.631
14"	337	1.029	514,5	558,8	20x41,3	640	85,8	460,5	460	F30	124,5	84,9	2 x 22	94,9	1.760	7.033	16.641
16"	375	1.130	565	616	20x44,5	705	88,9	418	580	F30	125	88	24	100	2.240	8.773	23.554
18"	423	1.219	609,5	685,8	20x50,8	785	101,6	582	621	F35	150,7	115	2 x 32	122	3.000	14.682	29.672
20"	471	1.321	660,5	749,3	20x54	855	108	575	635	F40	150	119,9	32	126,9	4.360	20.534	36.633
24"	571	1.549	774,5	901,7	20x66,7	1.040	139,7	596	760	F35	130	148	32	164	7.050	33.685	52.751

Fig. 6050 (Class 1500)

DN	øP	L ⁽²⁾	L1	øR	n x øS	øT	Y	h	N	ISO 5211	H	øA	J	K	WEIGHT	TORQUE	Kv
2"	49	368	184	165,1	8x25,4	215	38,1	161	124	F14	46	29	8	32,5	55	331	336
3"	74	470	235	203,2	8x31,8	265	47,7	214,5	163	F25	54,5	39,9	10	44,5	105	806	938
4"	102	546	273	241,3	8x34,9	310	54	236,7	213	F25	55,5	39,9	10	44,5	205	1.245	1.465
6"	146	705	352,5	317,5	12x38,1	395	82,6	324	321	F25	95	60	18	64	525	3.062	3.297
8"	194	832	416	393,7	12x44,5	485	92,1	410,5	323	F25	118,5	75	18	82,9	890	4.769	5.861
10"	241	991	495,5	482,6	12x50,8	585	108	402	415	F25	132,5	85	22	95	1.560	5.996	9.454
12"	289	1.146	573	571,5	16x54	675	123,9	399	565	F25	140	85	24	100	2.335	7.060	13.631

Fig. 6042 (Class 2500)

DN	øP	L ⁽²⁾	L1	øR	n x øS	øT	Y	h	N	ISO 5211	H	øA	J	K	WEIGHT	TORQUE	Kv
2"	45	451	225,5	171,4	8x28,6	235	50,9	162	132	F16	72	35	10	38	110	431	336
3"	64	578	289	228,6	8x34,9	305	66,7	182	151	F16	72	38	10	43	215	1.248	938
4"	89	673	336,5	273	8x41,3	355	76,2	275	221	F25	94,5	45	12	50	385	1.909	1.465
6"	133	914	457	368,3	8x54	485	108	303,1	332	F25	104,9	60	16	64	840	4.860	3.297
8"	181	1.022	511	438,2	12x54	550	127	356	495	F25	105,5	78	20	88	1.435	7.570	5.861

Dimensions in mm, weight in kg and Torque in Nm.
Weights and dimensions can be changed without notice.

Torque value given:
6015/6030 till 12" seats in RPTFE, from 14" seats in Devlon.
6060/6090/6050/6042 seats in Devlon.

FORGED BALL VALVES 7015 / 7030 / 7060 / 7090 / 7050 / 7042

Reduced Bore

Class 150.
From 3" to 42"

Class 300.
From 3" to 42"

Class 600.
From 3" to 30"

Class 900.
From 3" to 30"

Class 1500.
From 3" to 14"

Class 2500.
From 3" to 10"

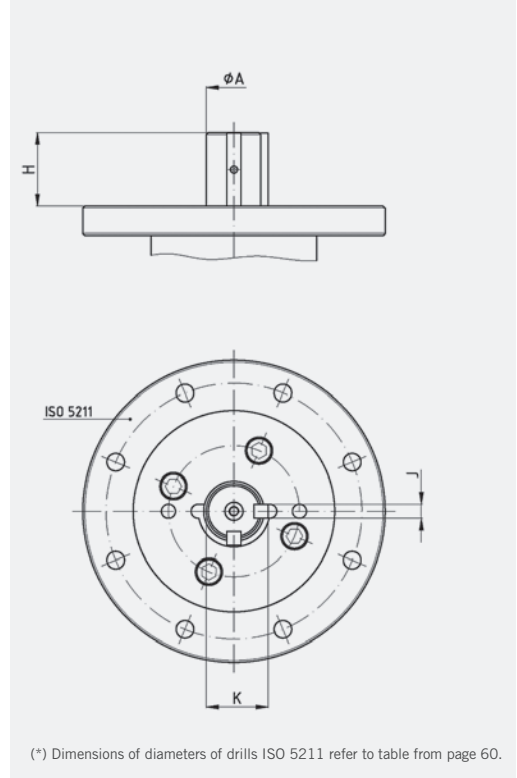
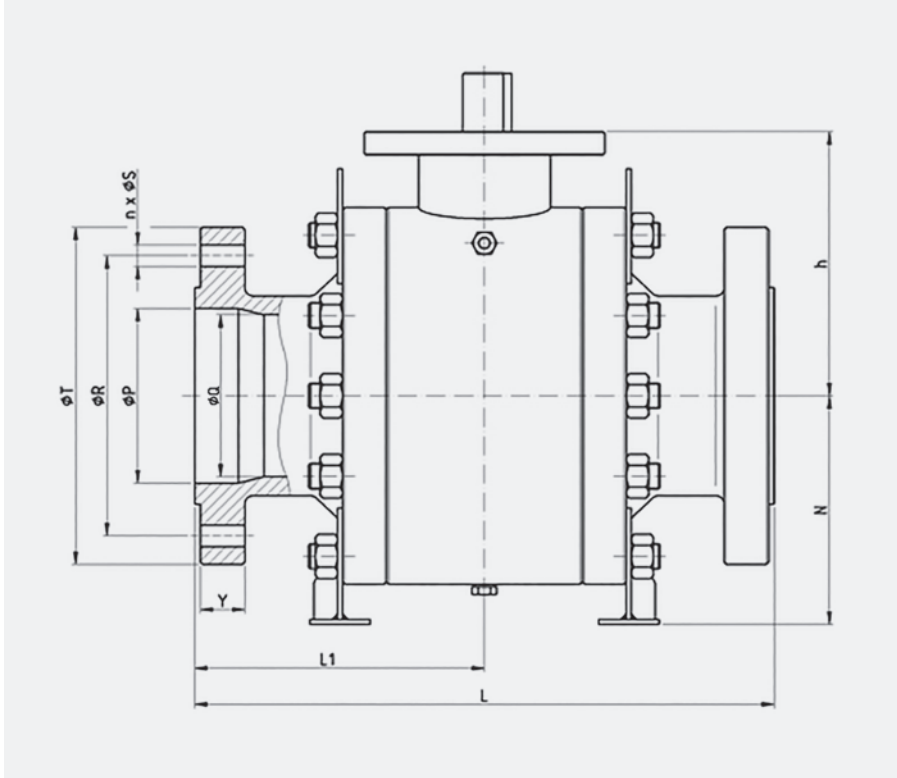

(*) Dimensions of diameters of drills ISO 5211 refer to table from page 60.

Pressure - Temperature

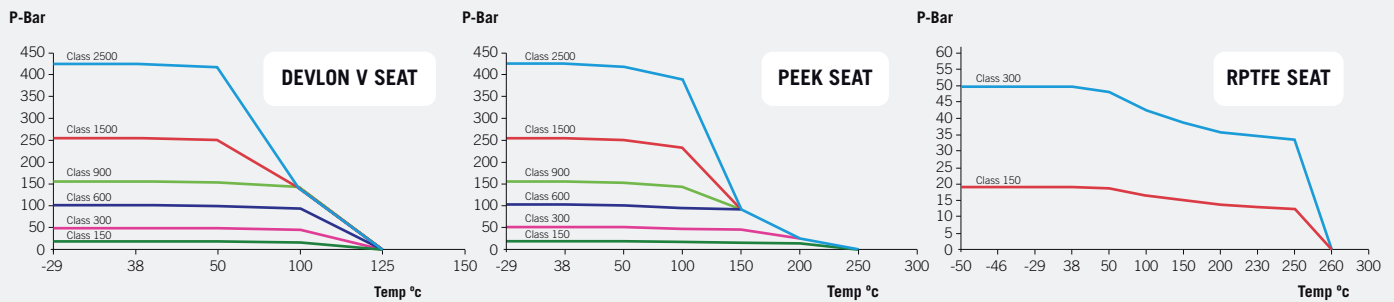

Fig. 7015 (Class 150)

DN	øP	øQ	L	L1	øR	n x øS	øT	Y	h	N	ISO 5211	H	øA	J	K	WEIGHT	TORQUE	Kv
3" x 2"	76	49	203	101,5	152,4	4x19,1	190	17,5	131,5	100	F10	30	19,9	8	22,5	66	62	190
4" x 3"	100	76	229	108,3	190,5	8x19,1	230	22,3	163	134	F12	31	26	10	30	75	130	567
6" x 4"	152	100	394	197	241,3	8x22,2	280	23,9	181,5	167	F12	47,5	29,9	10	34	115	219	815
8" x 6"	203	152	457	228,5	298,5	8x22,2	345	27	278	277	F16	61,5	39,9	14	48,9	205	351	2.021
10" x 8"	254	203	533	266,5	362	12x25,4	405	28,6	334,5	325	F25	67,5	49,9	14	58,4	375	648	4.205
12" x 10"	305	254	610	305	431,8	12x25,4	485	30,2	371	319	F25	75	59,9	2 x 16	67	565	805	7.348
14" x 12"	337	305	686	343	476,3	12x28,6	535	33,4	432,5	399	F25	94,5	69,9	2 x 18	78	825	997	10.120
16" x 14"	387	337	762	381	539,8	16x28,6	595	35	464,5	439	F30	109,5	79,9	2 x 22	87,9	1.250	2.258	12.000
18" x 16"	436	387	864	432	577,9	16x31,8	635	38,1	499,5	462	F30	121,5	84,9	2 x 22	94,9	1.820	3.120	17.269
20" x 18"	488	436	914	457	635	20x31,8	700	41,3	551,5	584	F30	138	99,9	2 x 28	111,9	2.450	4.107	18.647
24" x 20"	589	488	1.067	533,5	749,3	20x34,9	815	46,1	586,5	543	F30	138	99,9	2 x 28	111,9	2.790	5.133	27.010
30" x 24"	735	589	1.295	647,5	857	28x34,9	985	73	684	674	F35	153,5	120	32	134	5.530	10.536	32.150

Dimensions in mm, weight in kg and Torque in Nm.
Weights and dimensions can be changed without notice.

Torque value given:
7015/7030 till 12" seats in RPTFE, from 14" seats in Devlon.
7060/7090/7050/7042 seats in Devlon.

Fig. 7030 (Class 300)

DN	øP	øS	L	L1	øR	n x øS	øT	Y	h	N	ISO 5211	H	øA	J	K	WEIGHT	TORQUE	Kv
3" x 2"	76	49	283	141,5	168,3	8x22,2	210	27	131,5	100	F10	30	19,9	8	22,5	65	71	190
4" x 3"	100	76	305	152,5	200	8x22,2	255	30,2	163	134	F12	31	26	10	30	85	154	567
6" x 4"	152	100	403	201,5	269,9	12x22,2	320	35	181,5	167	F12	47,5	29,9	10	34	135	265	815
8" x 6"	203	152	502	251	330,2	12x25,4	380	39,7	278	277	F16	61,5	39,9	14	48,9	225	504	2.021
10" x 8"	254	203	568	284	387,4	16x28,6	445	46,1	334,5	293	F25	67,5	49,9	14	58,4	385	1.100	4.205
12" x 10"	305	254	648	324	450,8	16x31,8	520	49,3	371	335	F25	75	59,9	2 x 16	67	650	1.334	7.348
14" x 12"	337	305	762	381	514,4	20x31,8	585	52,4	432,5	386	F25	94,5	69,9	2 x 18	78	995	1.741	10.120
16" x 14"	387	337	838	419	571,5	20x34,9	650	55,6	464,5	430	F30	109,5	79,9	2 x 22	87,9	1.460	3.383	12.000
18" x 16"	436	387	914	457	628,6	24x34,9	710	58,8	499,5	472	F30	121,5	84,9	2 x 22	94,9	1.925	4.531	17.269
20" x 18"	488	436	991	495,5	685,8	24x34,9	775	62	551,5	596	F30	138	99,9	2 x 28	111,9	2.450	6.598	18.647
24" x 20"	589	488	1.143	571,5	812,8	24x41,3	915	68,3	586,5	610	F30	138	99,9	2 x 28	111,9	3.250	8.761	27.010
30" x 24"	735	589	1.397	698,5	857	28x48	1.092	90	684	674	F35	153,5	120	32	134	5.900	15.516	32.150

Fig. 7060 (Class 600)

DN	øP	øS	L	L1	øR	n x øS	øT	Y	h	N	ISO 5211	H	øA	J	K	WEIGHT	TORQUE	Kv
3" x 2"	76	49	356	178	168,3	8x22,2	210	31,8	131,5	100	F10	30	19,9	8	22,5	72	151	190
4" x 3"	100	76	432	216	215,9	8x25,4	275	38,1	163	139	F12	31	26	10	30	93	318	567
6" x 4"	152	100	559	279,5	292,1	12x28,6	355	47,7	181,5	164	F12	47,5	29,9	10	34	169	469	815
8" x 6"	203	152	660	330	349,2	12x31,8	420	55,6	278	278	F16	61,5	44,9	14	51,4	301	1.044	2.021
10" x 8"	254	203	787	393,5	431,8	16x34,9	510	63,5	334,5	296	F25	67,5	54,9	14	61,4	555	2.629	4.205
12" x 10"	305	254	838	419	489	20x34,9	560	66,7	371	365	F25	75	59,9	2 x 16	67	829	3.366	7.348
14" x 12"	337	305	889	444,5	527	20x38,1	605	69,9	432,5	419	F25	94	69,9	2 x 18	78	1.426	4.403	10.120
16" x 14"	387	337	991	495,5	603,2	20x41,3	685	76,2	464,5	450	F30	109,5	79,9	2 x 22	87,9	1.751	5.210	12.000
18" x 16"	436	387	1.092	546	654	20x44,5	745	82,6	499,5	505	F30	121,5	84,9	2 x 22	94,9	2.625	6.513	17.269
20" x 18"	488	436	1.194	597	723,9	24x44,5	815	88,9	551,5	568	F30	138	99,9	2 x 28	111,9	3.111	10.644	18.647
24" x 20"	589	488	1.397	698,5	838,2	24x50,8	940	101,6	586,5	581	F35	138	99,9	2 x 28	111,9	4.250	14.653	27.010
30" x 24"	735	589	1.651	825,5	857	28x54	1.130	108	684	758	F35	153,5	120	32	134	7.125	21.533	32.150

Fig. 7090 (Class 900)

DN	øP	øS	L	L1	øR	n x øS	øT	Y	h	N	ISO 5211	H	øA	J	K	WEIGHT	TORQUE	Kv
3" x 2"	76	49	381	190,5	190,5	8x25,4	240	38,1	161	124	F14	46	29	8	32,5	62	239	190
4" x 3"	100	76	457	228,5	235	8x31,8	290	44,5	204	153	F16	50	39,9	10	44,5	105	421	567
6" x 4"	152	100	610	305	317,5	12x31,8	380	55,6	236,7	211	F25	55,5	39,9	10	44,5	201	659	815
8" x 6"	203	152	737	368,5	393,7	12x38,1	470	63,5	277	287	F25	62,5	44,9	14	51,4	436	1.433	2.021
10" x 8"	254	203	838	419	469,9	16x38,1	545	69,9	345	299	F25	86,5	65	2 x 16	74,5	735	3.263	4.205
12" x 10"	305	254	965	482,5	533,4	20x38,1	610	79,4	402	377	F25	90	75	2 x 20	81	1.200	4.139	7.348
14" x 12"	337	305	1.029	514,5	558,8	20x41,3	640	85,8	432	420	F25	99	85	22	95	1.795	5.218	10.120
16" x 14"	387	337	1.130	565	616	20x44,5	705	88,9	460,5	460	F30	124,5	84,9	2 x 22	94,9	2.105	7.033	12.000
18" x 16"	436	387	1.219	609,5	685,8	20x50,8	785	101,6	418	580	F30	125	88	24	100	2.720	8.773	17.269
20" x 18"	488	436	1.321	660,5	749,3	20x54	855	108	582	621	F35	150,7	115	2 x 32	122	4.050	14.682	18.647
24" x 20"	589	488	1.549	774,5	901,7	20x66,7	1.040	139,7	575	635	F40	150	119,9	32	126,9	4.650	20.534	27.010
30" x 24"	712	589	1.803	901,5	857	20x72	1.232	142	596	760	F35	130	148	32	164	7.950	33.685	32.150

Fig. 7050 (Class 1500)

DN	øP	øS	L	L1	øR	n x øS	øT	Y	h	N	ISO 5211	H	øA	J	K	WEIGHT	TORQUE	Kv
3" x 2"	74	49	470	235	203,2	8x31,8	265	47,7	161	124	F14	46	29	8	32,5	80	331	190
4" x 3"	102	74	546	273	241,3	8x34,9	310	54	214,5	163	F25	54,5	39,9	10	44,5	156	806	567
6" x 4"	146	102	705	352,5	317,5	12x38,1	395	82,6	236,7	213	F25	55,5	39,9	10	44,5	325	1.245	815
8" x 6"	194	146	832	416	393,7	12x44,5	485	92,1	324	321	F25	95	60	18	64	603	3.062	2.021
10" x 8"	241	194	991	495,5	482,6	12x50,8	585	108	410,5	323	F25	118,5	75	18	82,9	950	4.769	4.205
12" x 10"	289	241	1.146	573	571,5	16x54	675	123,9	402	415	F25	132,5	85	22	95	1.825	5.996	7.348
14" x 12"	318	289	1.276	638	635	16x60	750	133,4	399	565	F25	140	85	24	100	2.750	7.060	10.120

Fig. 7042 (Class 2500)

DN	øP	øS	L	L1	øR	n x øS	øT	Y	h	N	ISO 5211	H	øA	J	K	WEIGHT	TORQUE	Kv
3" x 2"	64	45	578	289	228,6	8x34,9	305	66,7	162	132	F16	72	35	10	38	140	431	190
4" x 3"	89	64	673	336,5	273	8x41,3	355	76,2	182	151	F16	72	38	10	43	250	1.248	567
6" x 4"	133	89	914	457	368,3	8x54	485	108	275	221	F25	94,5	45	12	50	520	1.909	815
8" x 6"	181	133	1.022	511	438,2	12x54	550	127	303,1	332	F25	104,9	60	16	64	1.000	4.860	2.021
10" x 8"	226	181	1.292	646	539,8	12x66	675	165	356	495	F25	105,5	78	20	88	1.850	7.570	4.205

Dimensions in mm, weight in kg and Torque in Nm.
Weights and dimensions can be changed without notice.

Torque value given:
7015/7030 till 12" seats in RPTFE, from 14" seats in Devlon.
7060/7090/7050/7042 seats in Devlon.

| BALL VALVES |

2-PIECE CAST TRUNNION MOUNTED CAST TRUNNION

2" - 16" | Class 150 - Class 600

Materials CAST TRUNNION

Item	Description	AIT	IIT
1	Body	A 216 Gr. WCB (C ≤ 0.25%)	A 351 Gr. CF8M
2	Body connector	A 216 Gr. WCB (C ≤ 0.25%)	A 351 Gr. CF8M
3	Ball	A 351 Gr. CF8M	
4	Stem	A 479 Tp.316	
5	Seat ring	RPTFE, PTFE, DEVLON	
7	Gland nut	Zinc Plated Carbon Steel	AISI-303
8	Disk spring / Spring	Carbon St. *	E. N.P. Carbon St. *
9	Stop plate	Carbon St.	AISI-304
10	Gland ring	AISI-303	AISI-316
10.1	Gland	AISI-303	AISI-316
11	Gland packing	Graphite	
12	Stem thrust seal	25% G.F. PTFE	
13	Body connector seal	AISI-316L + Graphite	
14	Stop pin	Carbon St.	Stainless St.
15	Stud	A 193 Gr. B7M Zinc dichromate	A 193 Gr. B8M **
18	Thrust washer	25% G.F. PTFE	
19	Antistatic device	Stainless St.	
21 / 21a	Ball trunnion	A 351 Gr. CF8M	
22 / 22a	Trunnion bearing	AISI-316 + PTFE	
23	Bearing	PTFE	
26	Bolt	DIN 912 8.8 Zinc Plated	DIN 912 A2
28	Nut	A 194 Gr. 2HM Zinc dichromate	A 194 Gr. 8M **
31	Seat Carrier	A 351 Gr. CF8M	
32	Spring	Inconel - 750	
33	O' Ring	FKM -- Note 1 --	
35	Spring carrier	A 351 Gr. CF8M	
37	O' Ring	FKM -- Note 1 --	
39	Stem bushing	25% G.F. PTFE	
39.1	Stem bushing	AISI-316 + PTFE -- Note 2 --	
41	Spacer	Carbon St.	Stainless St.
43	Key	AISI-316	
46	Locking washer	AISI-304	
47	Key	Carbon St.	
50	Drain plug	A 105	AISI-316
50.1	Vent plug	A 105	AISI-316
52	O' Ring	FKM -- Note 2 --	
54	Seat carrier seal	Graphite	
58	Spring protection	Carbon St.	Stainless St.
72	O' Ring	FKM -- Note 1 --	
75	Stem bushing	AISI-316 + PTFE -- Note 2 --	
89	Identification plate	Stainless St.	
471	Retainer	Carbon St.	Stainless St.

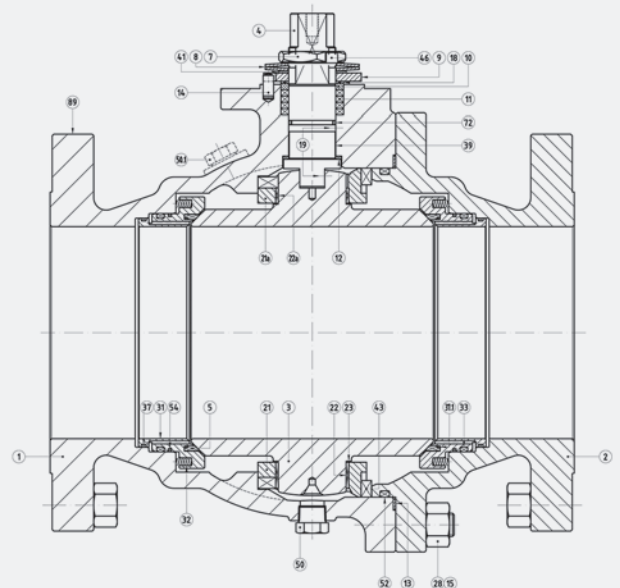
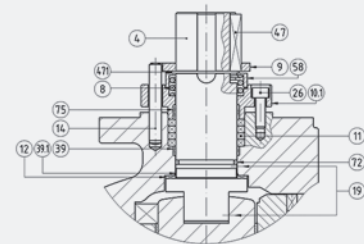

(*) On request Inconel X-750.

(**) On request B7M / 2HM Zinc Plated & Bichromated.

Note 1: Depending on design conditions AFLAS, KALREZ or KALREZ Spectrum.

Note 2: Only DN-350 & 400 and all Fig.2560.

CAST BALL VALVES 2515 / 2530 / 2560
Class 150 / 300 / 600
Full Bore
Class 150. From 2" to 16"
Class 300. From 2" to 16"
Class 600. From 2" to 12"

 DN 50 (2") to DN-250 (10") Class-150 & 300
 DN-50 (2") to DN-100 (4") Class-600

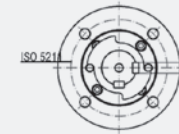
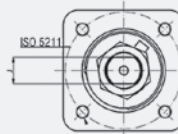
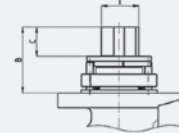
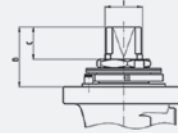
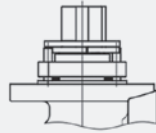
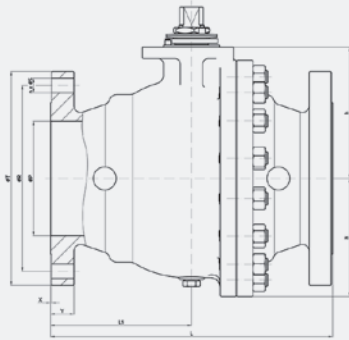
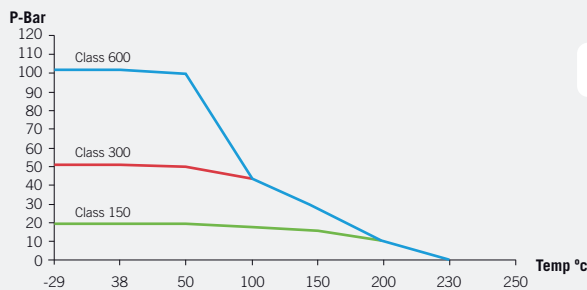
 DN 300 (12") to DN-400 (16") Class-150 & 300
 DN-150 (6") to DN-300 (12") Class-500

Pressure - Temperature

(*) Dimensions of diameters of drills ISO 5211 refer to table from page 60.

Fig. 2515 (Class 150)

DN	øP	L	L1	øR	n x øS	øT	h	N	ISO 5211	B	C	I	J	K	WEIGHT	TORQUE	Kv
50 (2")	50	178	78.5	120,7	4x19	150	84	80	F07	42	17	M22x1,5	16	-	13	70	366
80 (3")	80	203	87	152,4	4x19	190	126	-	F10	55	27	M28x1,5	20	-	22	130	938
100 (4")	100	229	101	190,5	8x19	230	152	120	F12	56	27	M35x2	25	-	39	190	1.465
150 (6")	151	394	197	241,3	8x22,2	280	212	168	F14	70	36	M45x2	32	-	98	460	3.297
200 (8")	203	457	230	298,5	8x22,2	345	233	208	F14	70	37	M45x2	32	-	124	610	5.861
250 (10")	254	533	267	362	12x25,4	405	256	243	F14	70	37	M45x2	32	-	175	660	9.454
300 (12")	305	610	305	431,8	12x25,4	485	297	287,5	F14	106	58	Ø50	14	53,5	295	1.317	13.631
350 (14")	337	686	343	476,3	12x28,5	535	333	323	F16	103	49	Ø60	18	64,2	580	2.605	16.641
400 (16")	388	762	381	539,8	16x28,5	595	412	358	F25	159	103	Ø90	25	95,3	750	2.948	23.554

Fig. 2530 (Class 300)

DN	øP	L	L1	øR	n x øS	øT	h	N	ISO 5211	B	C	I	J	K	WEIGHT	TORQUE	Kv
50 (2")	50	216	84	127	8x19	165	84	-	F07	42	17	M22x1,5	16	-	16	80	366
80 (3")	80	283	115	168,3	8x22,2	210	126	-	F10	55	27	M28x1,5	20	-	33	140	938
100 (4")	100	305	133	200	8x22,2	255	152	-	F12	56	27	M35x2	25	-	43	240	1.465
150 (6")	151	403	202	269,9	12x22,2	320	212	173	F14	70	36	M45x2	32	-	113	598	3.297
200 (8")	203	502	252	330,2	12x25,4	380	233	210	F14	70	37	M45x2	32	-	157	1.400	5.861
250 (10")	254	568	284	387,4	16x28,5	445	257	253	F14	70	37	M45x2	32	-	263	1.604	9.454
300 (12")	305	648	315	450,8	16x31,8	520	310	300	F16	103	49	Ø60	18	64,2	480	2.310	13.631
350 (14")	337	762	381	514,4	20x34,9	585	333	331	F16	103	49	Ø60	18	64,2	655	3.642	16.641
400 (16")	388	838	419	571,5	20x34,9	650	412	365	F25	159	103	Ø90	25	95,3	890	3.900	23.554

Fig. 2560 (Class 600)

DN	øP	L	L1	øR	n x øS	øT	h	N	ISO 5211	B	C	I	J	K	WEIGHT	TORQUE	Kv
50 (2")	50	292	96	127	8x19,1	165	84	-	F07	42	17	M22x1,5	16	-	20	90	366
80 (3")	80	356	140	168,3	8x22,2	210	126	113	F10	55	27	M28x1,5	20	-	41	170	938
100 (4")	100	432	160	215,9	8x25,2	275	152	-	F12	56	27	M35x2	25	-	77	392	1.465
150 (6")	151	559	246	292,1	12x28,5	355	212	188	F14	97	49	Ø45	14	48,5	192	1.007	3.297
200 (8")	203	660	315	349,2	12x31,8	420	237	235	F14	113	64	Ø50	14	53,5	329	2.057	5.861
250 (10")	254	787	340	431,8	16x34,9	510	275	273	F16	103	49	Ø60	18	64,2	460	3.013	9.454
300 (12")	305	838	404	489	20x34,9	560	345	335	F16	127	73	Ø65	18	69,2	570	5.500	13.631

 Dimensions in mm, weight in kg and Torque in Nm.
 Weights and dimensions can be changed without notice.

| BALL VALVES |

FLOATING ASME

1/2" - 12" | Class 150 - Class 1500

A floating ball valve is a valve with seats supported ball, that is pushed by upstream pressure towards the downstream seat to ensure sealing. The DN of the floating ball valves range is limited by the capability of the seats material to support the pressure, temperature and weight of the ball.

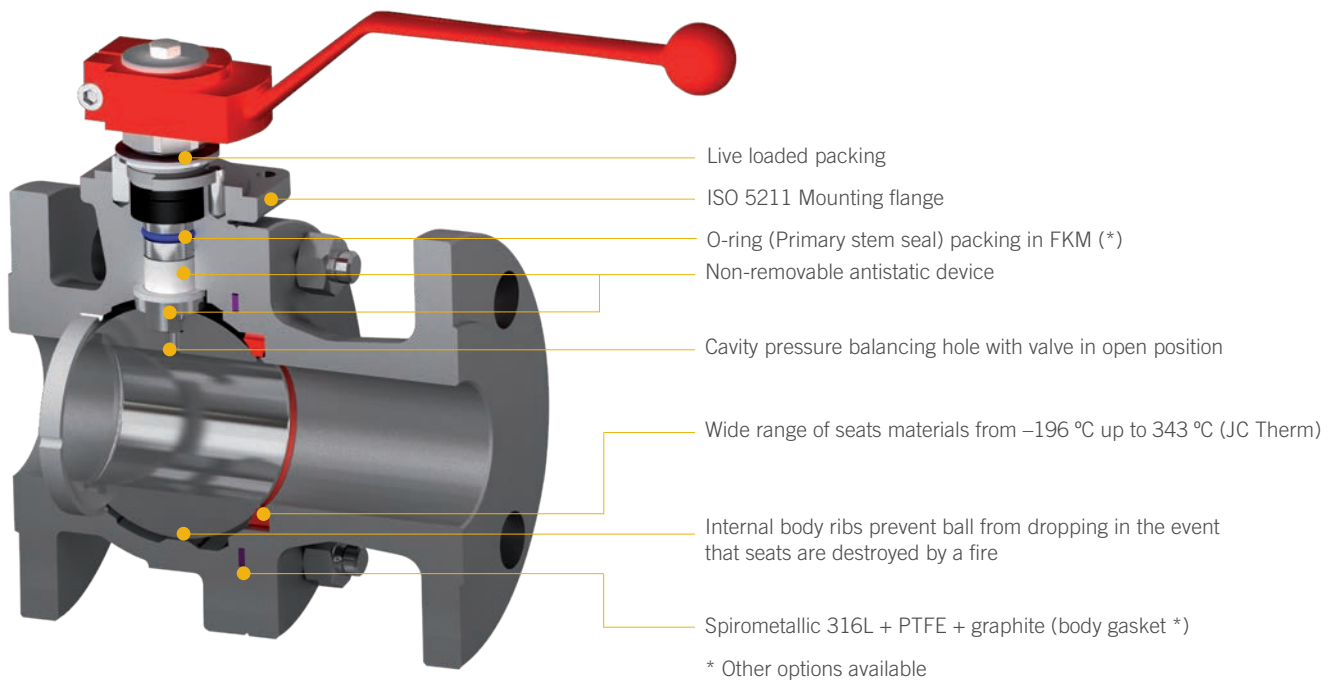

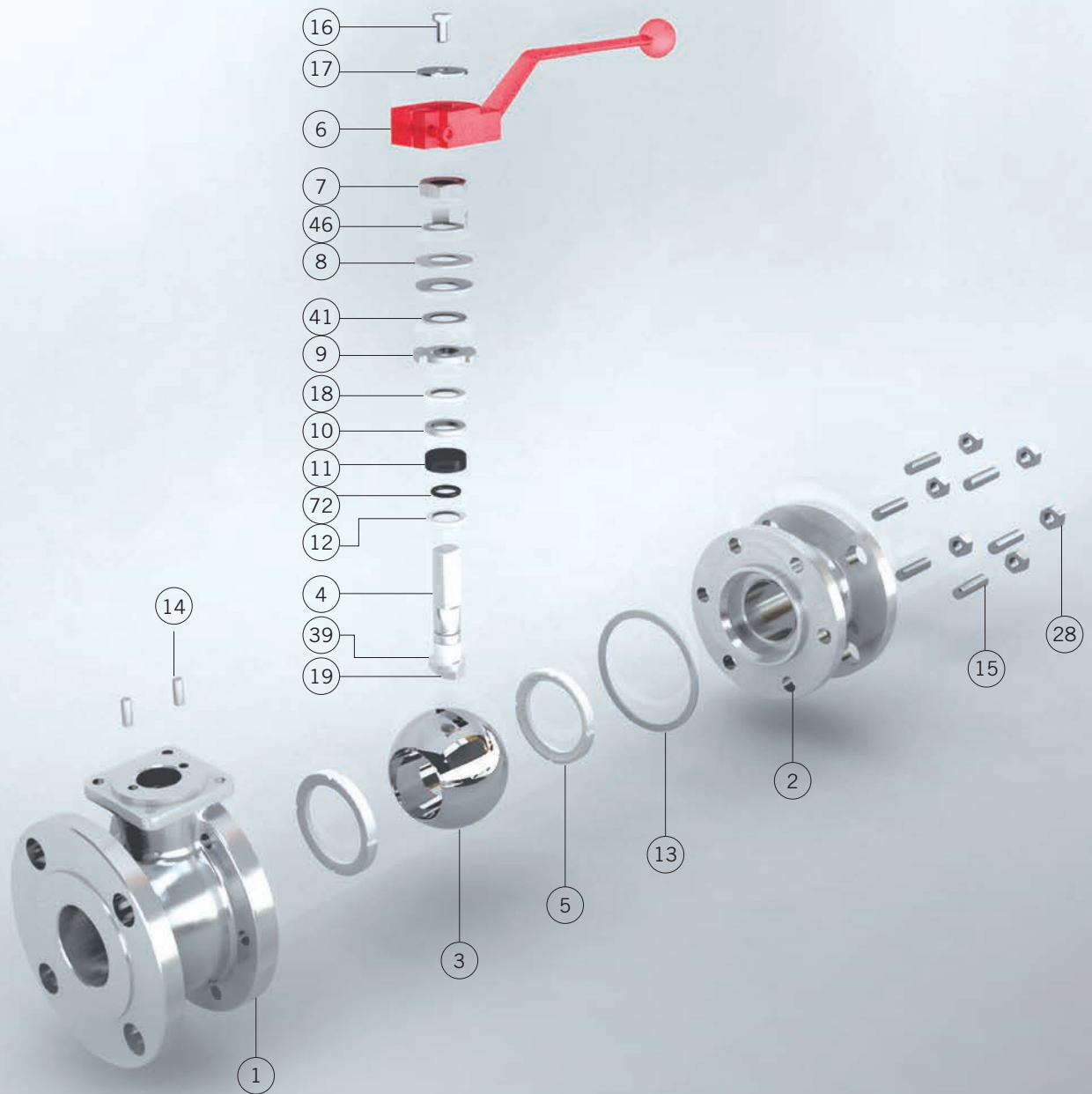

Materials ASME

Item	Description	AIT	LIT	IIT
1	Body	A 216 Gr. WCB (C ≤ 0,25%)	A 352 Gr. LCC	A 351 Gr. CF8M
2	Body connector	A 216 Gr. WCB (C ≤ 0,25%)	A 352 Gr. LCC	A 351 Gr. CF8M
3	Ball		A 351 Gr. CF8M (DN 15 : 50 A 479 Tp.316)	
4	Stem		A 479 Tp.316	
5	Seat ring		PTFE, PEEK, NYLON, DEVLON	
6	Wrench		Nodular Iron	
7	Gland nut	Zinc plated carbon steel	AISI 303	AISI 303
8	Disk spring	Carbon St.	A 666 Tp.301	A 666 Tp.301
9	Stop plate	Carbon St.	AISI 304	AISI 304
10	Gland	AISI 303	AISI 316	AISI 316
11	Gland packing		Graphite	
12	Stem thrust seal		25% G.F. PTFE	
13	Body connector seal		AISI 316L + PTFE + Graphite	
14	Stop pin	Carbon St.	Stainless St.	Stainless St.
15	Stud	A 193 Gr. B7M Zinc dichromate	A 193 Gr. L7M + Zinc dichromate	A 193 Gr. B8M
16	Bolt	DIN 933 5.6 Zinc plated	DIN 933 A2	DIN 933 A2
17	Washer	Zinc plated carbon steel	AISI 304	AISI 304
18	Thrust washer		25% G.F. PTFE	
19	Antistatic device		Stainless St.	
28	Nut	A 194 Gr. 2HM Zinc dichromate	A 194 Gr. 7M + Zinc dichromate	A 194 Gr. 8M
39	Stem bushing (DN 25 to 200)		25% G.F. PTFE	
41	Spacer (DN 40 to 200)	Carbon St.	AISI 304	AISI 304
46	Washer	AISI-304	AISI 304	AISI 304
72	"O" Ring		FKM	
89	Identification plate		Stainless St.	

ASME 515 / 530

Class 150 / 300

Full Bore

Class 150. From 1/2" to 8"

Class 300. From 1/2" to 6"

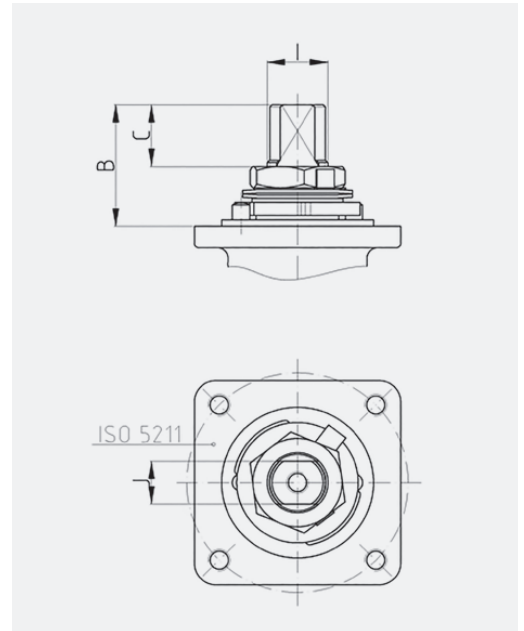
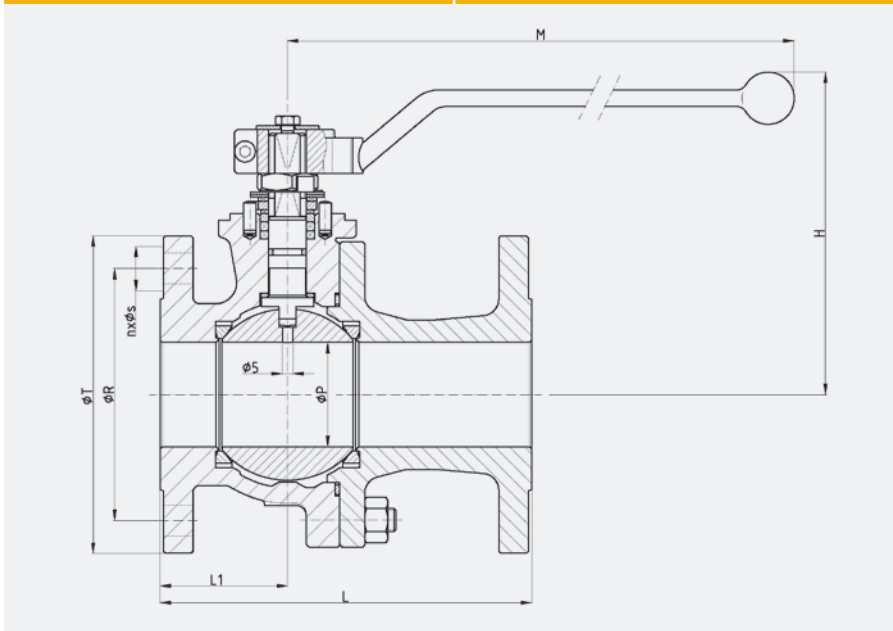

Pressure - Temperature

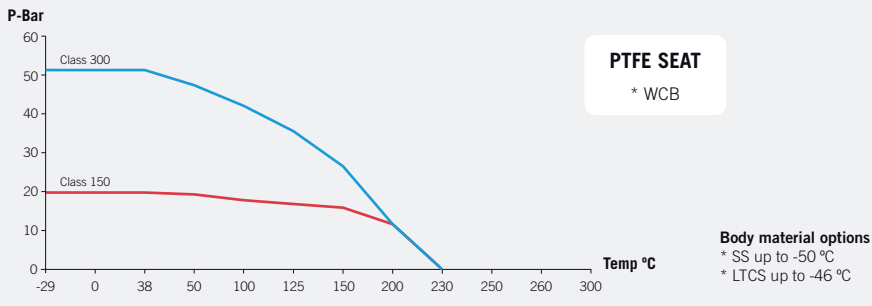

(*) Dimensions of diameters of drills ISO 5211 refer to table from page 60.



Fig. 515 (Class 150)

DN	ØP	L	L1	ØR	n x ØS	ØT	H	M	ISO 5211	B	C	I	J	WEIGHT	TORQUE	Kv
15 (1/2")	15	108	47	60,3	4x15,9	90	111	164	F05	11,2	5	M12x1,5	9	2	9	20
20 (3/4")	20	117	50	69,9	4x15,9	100	118	164	F05	14,7	8,5	M12x1,5	9	3	13	40
25 (1")	25	127	52	79,4	4x15,9	110	130	164	F05	22,7	9,5	M12x1,5	9	3,5	17	75
40 (1 1/2")	40	165	65	98,4	4x15,9	125	148	213	F07	41,5	18,3	M18x1,5	13	8	30	170
50 (2")	50	178	61	120,7	4x19,1	150	155	213	F07	41,5	18,3	M18x1,5	13	11	43	270
65 (2 1/2")	65	190	75	139,7	4x19,1	180	169	348	F07	44	18,6	M22x1,5	16	16	66	550
80 (3")	80	203	78,5	152,4	4x19,1	190	207	445	F10	44,5	18,6	M25x1,5	18	23	102	1.000
100 (4")	100	229	90	190,5	8x19,1	230	232	495	F10	56,5	27,8	M28x1,5	20	38	150	1.650
150 (6")	151	394	174	241,3	8x22,2	280	298	698	F12	68	37,1	M40x2	29	88	326	4.200
200 (8")	203	457	200	298,5	8x22,2	345	353	868	F14	72	36,5	M45x2	32	155	729	9.000

Fig. 530 (Class 300)

DN	ØP	L	L1	ØR	n x ØS	ØT	H	M	ISO 5211	B	C	I	J	WEIGHT	TORQUE	Kv
15 (1/2")	15	140	60	66,7	4x15,9	95	111	164	F05	11,2	5	M12x1,5	9	3	12	20
20 (3/4")	20	152	65	82,6	4x19,1	115	118	164	F05	14,7	8,5	M12x1,5	9	4	16	40
25 (1")	25	165	70	88,9	4x19,1	125	130	164	F05	22,7	9,5	M12x1,5	9	5	20	75
40 (1 1/2")	40	190	80	114,3	4x22,2	155	148	213	F07	41,5	18,3	M18x1,5	13	11	37	170
50 (2")	50	216	83	127	8x19,1	165	155	213	F07	41,5	18,3	M18x1,5	13	14	55	270
80 (3")	80	282	118	168,3	8x22,2	210	207	445	F10	44,5	18,6	M25x1,5	18	32	128	1.000
100 (4")	100	305	133	200	8x22,2	255	232	495	F10	56,5	27,8	M28x1,5	20	52	238	1.650
150 (6")	151	403	160	269,9	12x22,2	320	298	698	F12	68	37,1	M40x2	29	94	492	4.200

Dimensions in mm, weight in kg and Torque in Nm. Weights and dimensions can be changed without notice.

ASME 715 / 730

Class 150 / 300

Reduced Bore

Class 150. From ½" to 12"

Class 300. From ½" to 8"

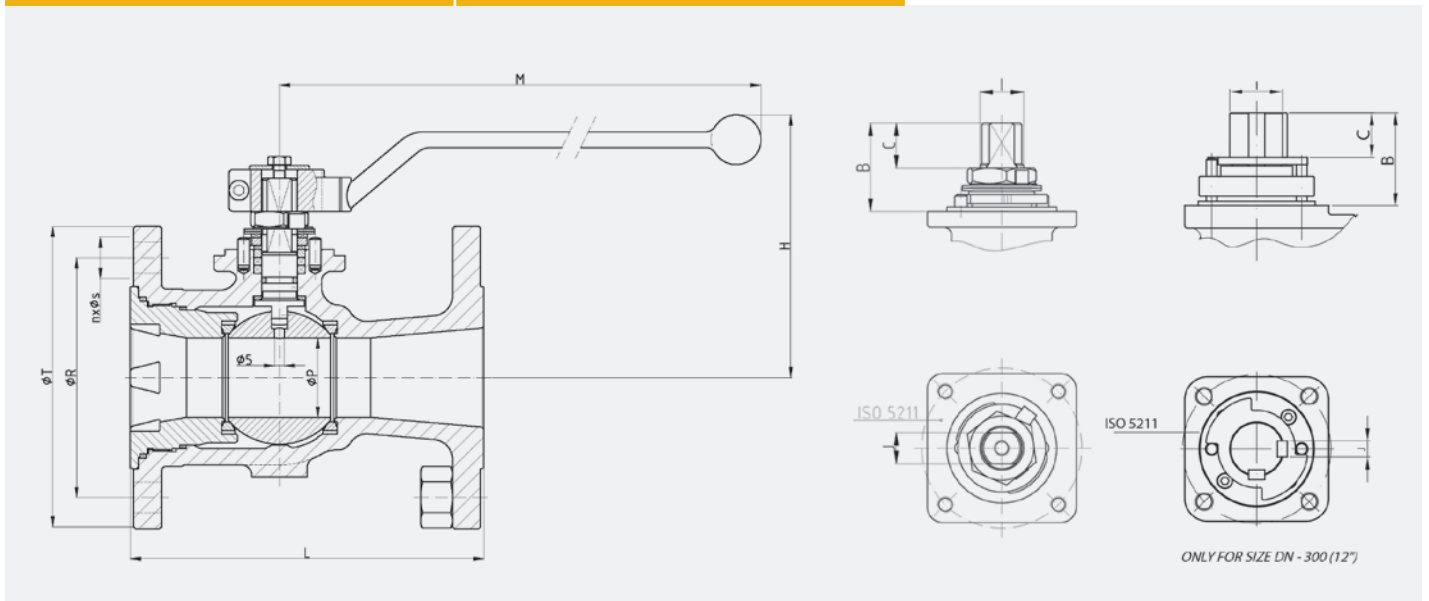

Pressure - Temperature

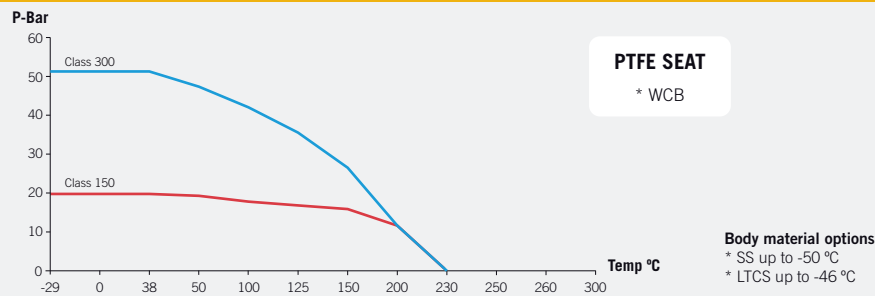

(*) Dimensions of diameters of drills ISO 5211 refer to table from page 60.



Fig. 715 (Class 150)

DN	ØP	L	L1	ØR	n x ØS	ØT	H	M	ISO 5211	B	C	I	J	WEIGHT	TORQUE	Kv
15 (½")	9,5	108	54	60,3	4x15,9	90	81	164	F05	22	7,9	M10x1,5	7	1,6	8	7
20 (¾")	15	117	50	69,9	4x15,9	100	99	164	F05	22,7	8,5	M12x1,5	9	2,1	9	10
25 (1")	20	127	65	79,4	4x15,9	110	102	164	F05	22,7	8,5	M12x1,5	9	2,7	11	26
40 (1 ½")	32	165	72	98,4	4x15,9	125	117	210	F05	34,5	14	M16x1,5	12	5,1	17	107
50 (2")	40	178	75	120,7	4x19,1	150	133	213	F07	42	18,8	M18x1,5	13	7,9	28	140
80 (3")	58	203	88	152,4	4x19,1	190	148	348	F07	44	18,6	M22x1,5	16	14,3	58	300
100 (4")	80	229	104	190,5	8x19,1	230	189	445	F10	44,5	18,6	M25x1,5	18	25,9	90	600
150 (6")	111	267	125	241,3	8x22,2	280	228	495	F12	56,5	27,8	M28x1,5	20	43,8	228	1.000
200 (8")	144	292	135	298,5	8x22,2	345	267	698	F12	56	24,8	M35x2	25	77	352	2.000
250 (10")	187	330	165,5	362	12x25,4	405	-	-	F12	68,4	37,5	M40x2	29	114	650	4.100
(1) 300 (12")	228	356	178	431,8	12x25,4	485	-	-	F14	97	56	Ø50	14	230	980	6.900

Fig. 730 (Class 300)

DN	ØP	L	L1	ØR	n x ØS	ØT	H	M	ISO 5211	B	C	I	J	WEIGHT	TORQUE	Kv
15 (½")	9,5	140	54	66,7	4x15,9	95	81	164	F05	22	7,9	M10x1,5	7	1,6	10	7
20 (¾")	15	152	60	82,6	4x19,1	115	99	164	F05	22,7	8,5	M12x1,5	9	2,1	12	10
25 (1")	20	165	65	88,9	4x19,1	125	102	164	F05	22,7	8,5	M12x1,5	9	4,1	16	26
40 (1 ½")	32	190	72	114,3	4x22,2	155	117	210	F05	34,5	14	M16x1,5	12	8,2	26	107
50 (2")	40	216	75	127	8x19,1	165	134	213	F07	42	18,8	M18x1,5	13	10,9	35	140
80 (3")	58	282	88	168,3	8x22,2	210	148	348	F07	44	18,6	M22x1,5	16	21,4	70	300
100 (4")	80	305	104	200	8x22,2	255	189	445	F10	44,5	18,6	M25x1,5	18	28,9	90	600
150 (6")	111	403	125	269,9	12x22,2	320	228	495	F12	56,5	27,8	M28x1,5	20	70	280	1.000
200 (8")	144	419	135	330,2	12x25,4	380	267	698	F12	56	24,8	M35x2	25	110,5	515	2.000

Dimensions in mm, weight in kg and Torque in Nm.
Weights and dimensions can be changed without notice.
(1) Body and Body connector joint is not threaded, is with screws.

ASME 560

Class 600

Full Bore

Class 600. From 1/2" to 4"

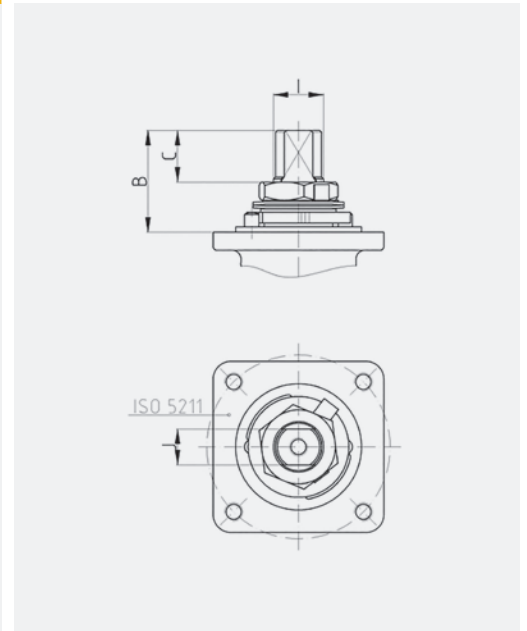
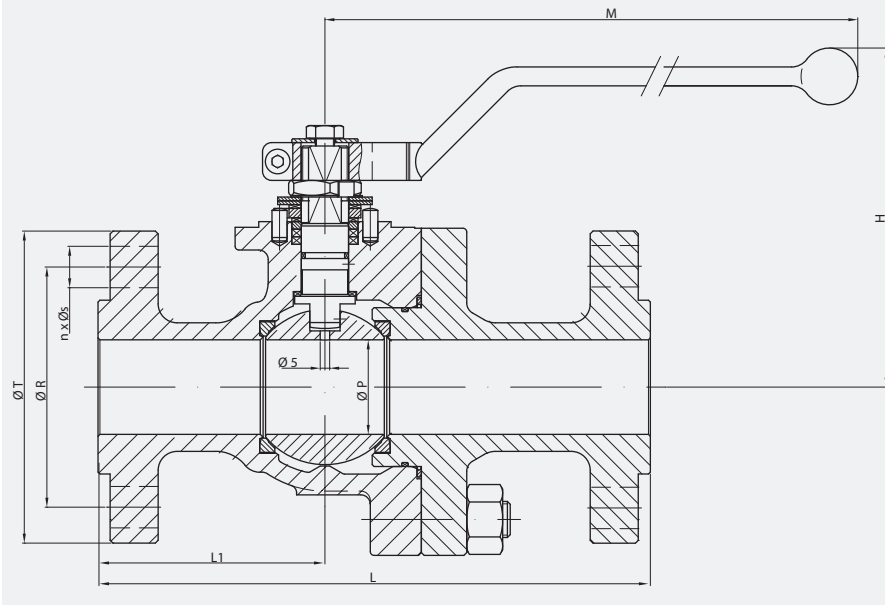

(*) Dimensions of diameters of drills ISO 5211 refer to table from page 60.

Pressure - Temperature

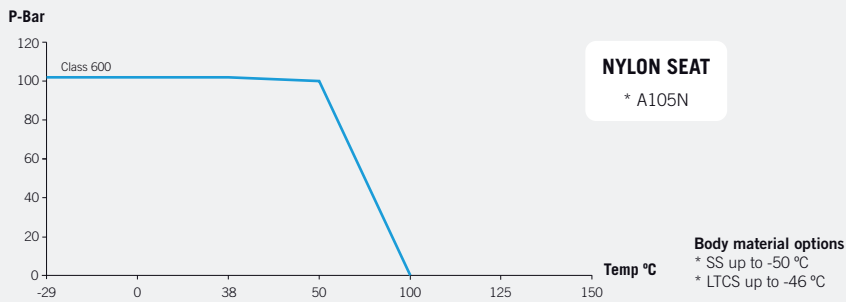

Fig. 560 (Class 600)

DN	ØP	L	L1	ØR	n x ØS	ØT	H	M	ISO 5211	B	C	I	J	WEIGHT	TORQUE	Kv
15 (1/2")	15	165	70	66,7	4x15,9	95	111	164	F05	11,2	5	M12x1,5	9	5,5	23	22
20 (3/4")	20	190	86	82,6	4x19,1	115	117	164	F05	23,7	10,5	M12x1,5	9	8	25	43
25 (1")	25	216	94	88,9	4x19,1	125	119	210	F05	33,5	13	M16x1,5	12	10	65	81
40 (1 1/2")	40	241	104	114,3	4x22,2	155	138	348	F07	43	17,6	M22x1,5	16	19	88	224
50 (2")	50	292	120	127	8x19,1	165	181	445	F10	45	19,1	M25x1,5	18	29	114	270
80 (3")	80	356	151	168,3	8x22,2	210	231	698	F12	55,5	24,3	M35x2	25	42	310	1.000
100 (4")	100	432	172	215,9	8x25,4	275	248	698	F12	55	23,8	M35x2	25	78	484	1.650

Dimensions in mm, weight in kg and Torque in Nm. Weights and dimensions can be changed without notice.

ASME 660

Class 600

Reduced Bore

Class 600. From 2" to 4"

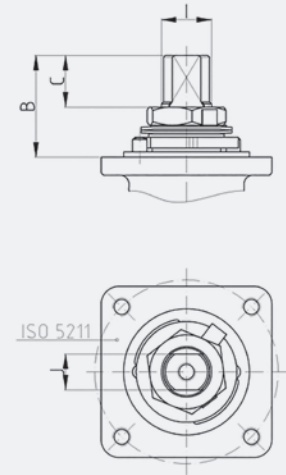
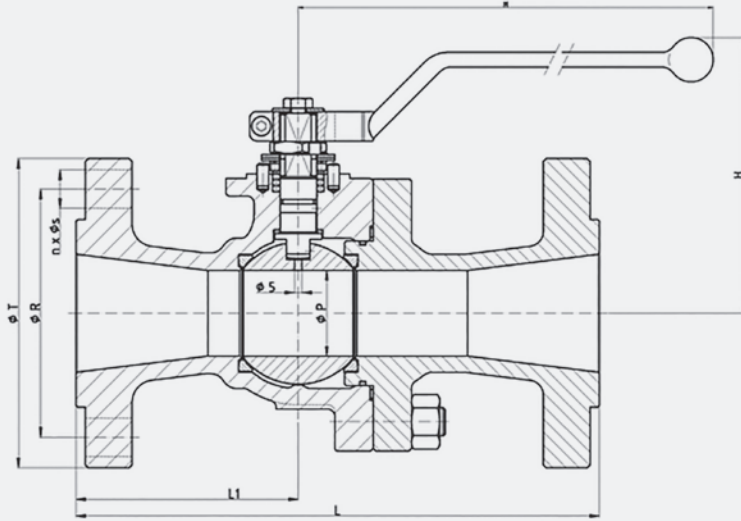

(*) Dimensions of diameters of drills ISO 5211 refer to table from page 60.

Pressure - Temperature

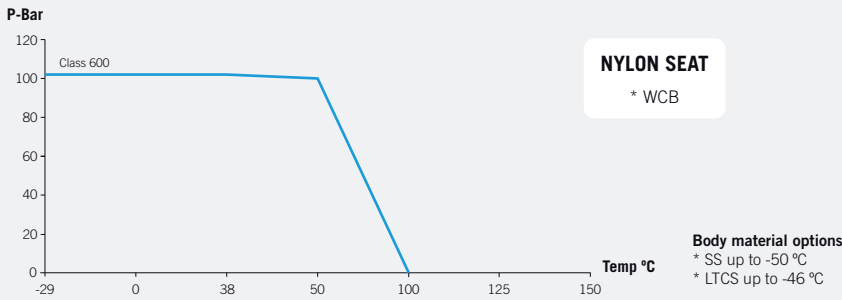

Fig. 660 (Class 600)

DN	ϕP	L	L1	ϕR	$n \times \phi S$	ϕT	H	M	ISO 5211	B	C	I	J	WEIGHT	TORQUE	Kv
50 (2")	40	292	120	127	8x19,1	165	137	348	F07	43	17,6	M22x1,5	16	17	88	140
80 (3")	58	356	151	168,3	8x22,2	210	187	445	F10	44	18,1	M25x1,5	18	30	165	300
100 (4")	80	432	190	215,9	8x25,4	275	231	698	F12	55,5	24,3	M35x2	25	64	310	600

Dimensions in mm, weight in kg and Torque in Nm.
Weights and dimensions can be changed without notice.

| BALL VALVES |

3 PIECE FORGED BALL VALVES ASME

From ¼" to 2" | Class 800 - Class 1500

Forging is a manufacturing process where metal is shaped by plastic deformation under great pressure into high strength parts. The JC 3 piece forged ball valves are designed with excellent Mechanical properties, yield strength, ductility, toughness, Reliability (used for critical applications).

LOCKING DEVICE



STEM EXTENSION

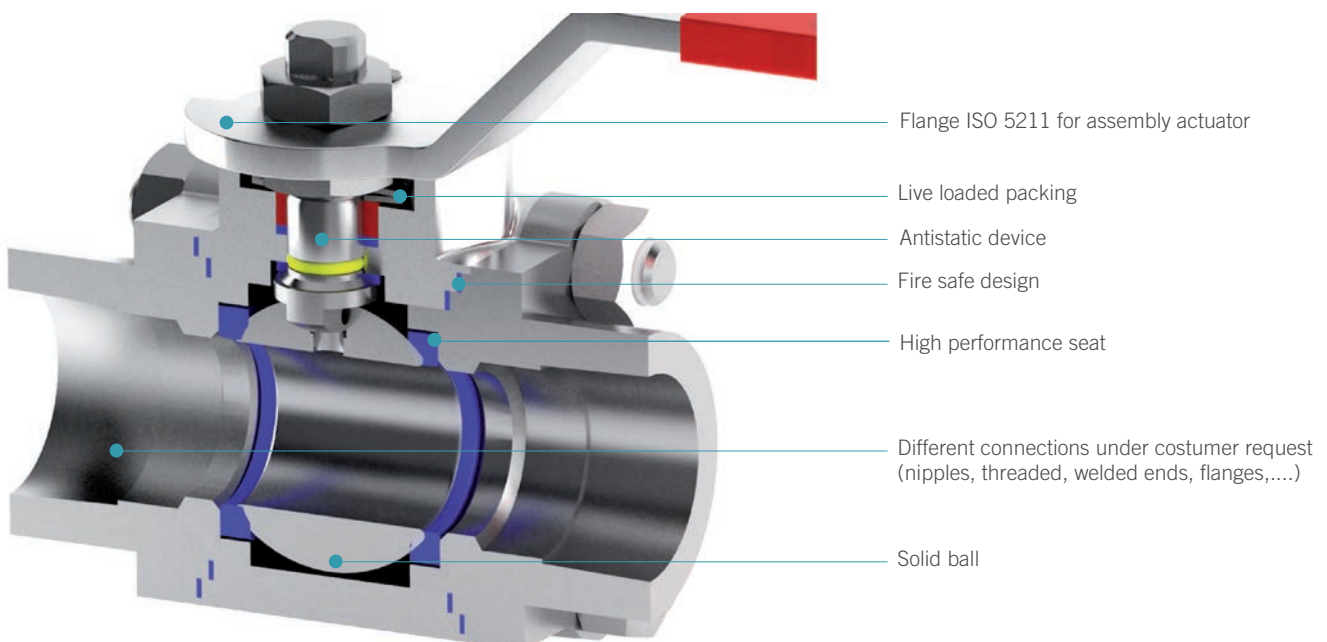

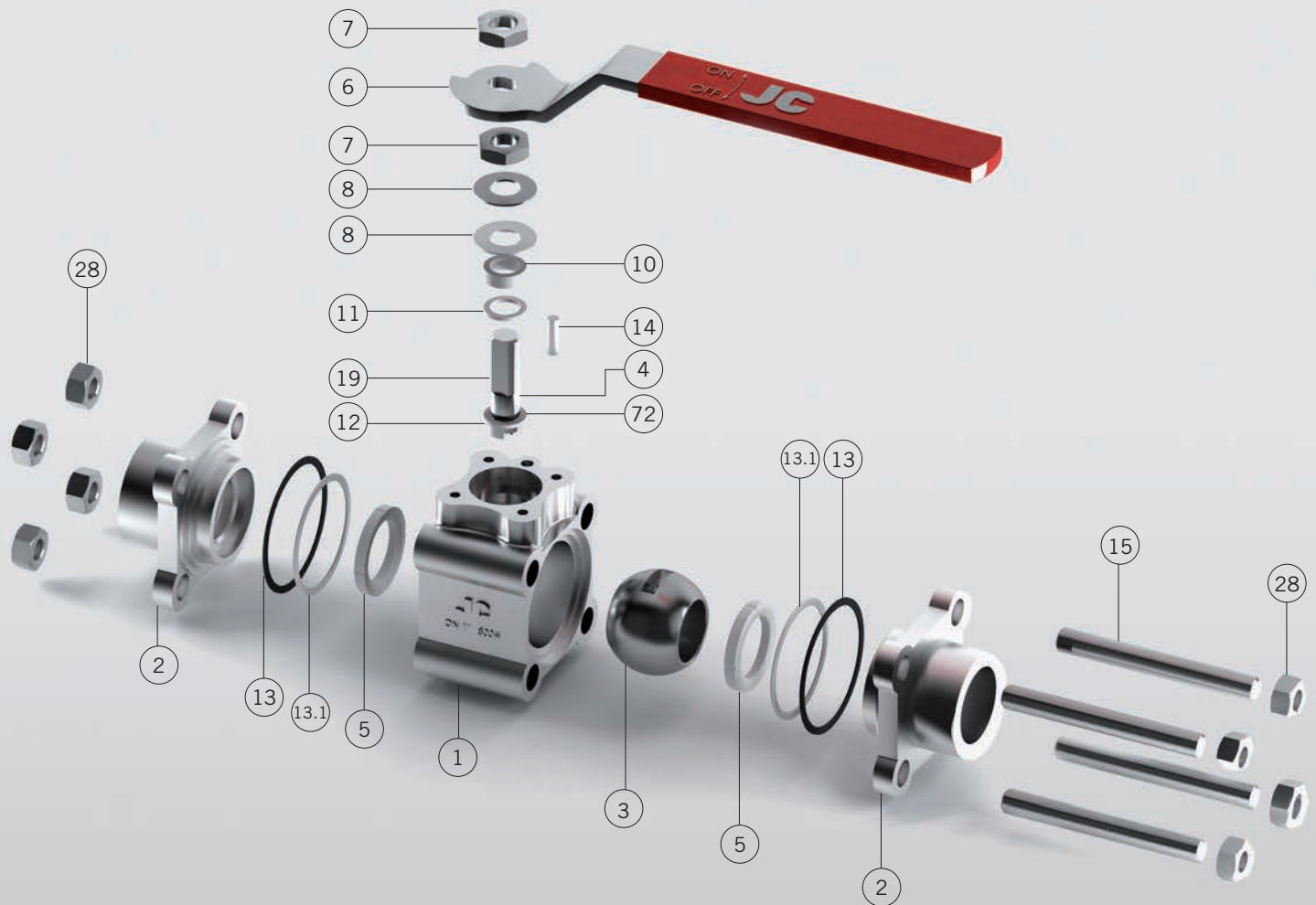

Materials

800

81500

Item	Description	Carbon Steel	Stainless Steel	Carbon Steel	Stainless Steel
1	Body	ASTM A105	ASTM A182 Gr. F316	ASTM A105 / A350 LF2	ASTM A182 Gr. F316
2	End Connector	ASTM A105	ASTM A182 Gr. F316	ASTM A105 / A350 LF2	ASTM A182 Gr. F316
3	Ball	A 479 Tp. 316	A 479 Tp. 316	A 479 Tp. 316	A 479 Tp. 316
4	Stem	A 479 Tp. 316	A 479 Tp. 316	A 479 TP410	17-4-PH
5	Seat ring	TFM-1600+CG	TFM-1600+CG	DEVLON "V" (*)	DEVLON "V" (*)
6	Wrench	Z.P. Carbon Steel	Z.P. Carbon Steel	Z.P. Carbon Steel	Z.P. Carbon Steel
7	Gland nut	Z.P. Carbon Steel	AISI 316	Z.P. Carbon St.	AISI 316
8	Disk Spring	Carbon Steel	AISI 301	Carbon Steel	AISI 301
10	Gland	AISI 316	AISI 316	AISI 316	AISI 316
11	Gland packing	Graphite	Graphite	Graphite	Graphite
12	Stem thrust seal	PTFE + 25% Graphite	PTFE + 25% Graphite	PTFE + 25% Graphite	PTFE + 25% Graphite
13	Body connector seal	Graphite	Graphite	Graphite	Graphite
13.1	Body connector seal	FKM (**)	FKM (**)	FKM (**)	FKM (**)
14	Stop pin	Stainless Steel	Stainless Steel	Stainless Steel	Stainless Steel
15	Stud	ASTM A 193 B7M	ASTM A 193 B8M	ASTM A 193 B7M	ASTM A 193 B8M
19	Antistatic device	Stainless Steel	Stainless Steel	Stainless Steel	Stainless Steel
28	Nut	ASTM A 194 2HM	ASTM A 194 Gr8M	ASTM A 194 2HM	ASTM A 194 Gr8M
72	O'ring	FKM	FKM	FKM	FKM
89	Identification plate	Stainless Steel	Stainless Steel	Stainless Steel	Stainless Steel

ASME 800

Class 800

Full Bore

Class 800. From 1/4" to 2"

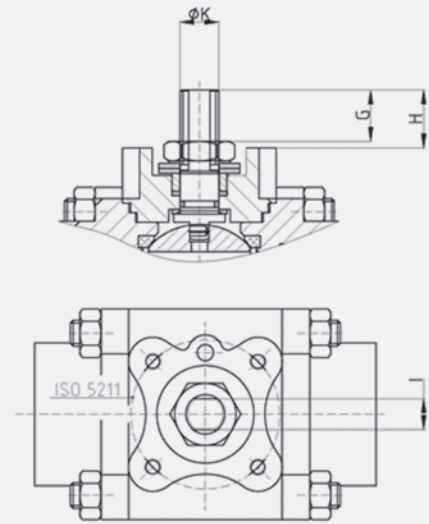
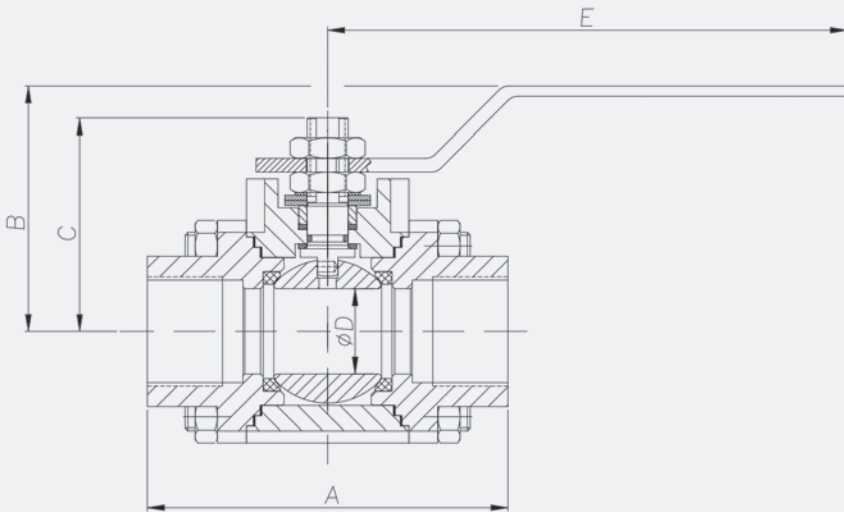

Pressure - Temperature

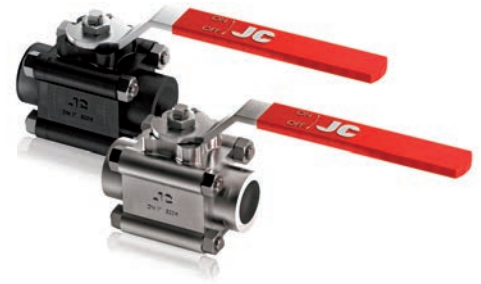
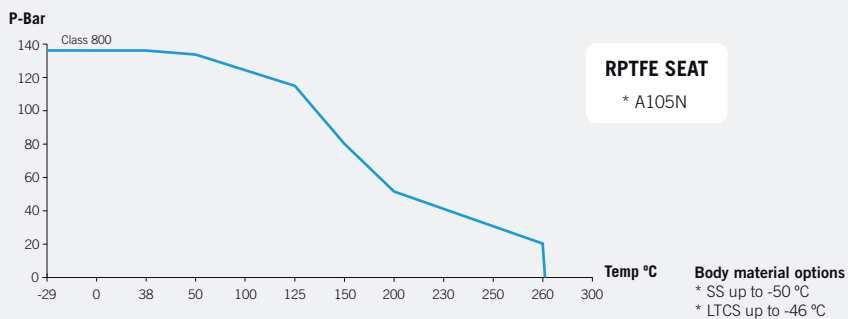

Fig. 800 (Class 800)

DN	A	B	C	ØD	E	ISO 5211	G	H	I	N° x J	ØK	WEIGHT	TORQUE
3/8"	68	60	71	9,5	170	F03	7,5	11	7	4xM5	M10x1	0,9	8
1/2"	72	62	75	15	170	F03	9,5	13,3	7	4xM5	M10x1	1	9
3/4"	94	75	93	20	215	F04	13,4	18,4	9,5	4xM5	M12x1,5	2	18
1"	106	78	99	25	215	F04	15,7	21,4	9,5	4xM5	M12x1,5	2,5	22
1 1/2"	125,5	99	132	40	245	F05	26	33,3	9,5	4xM6	M16x1,5	5,6	51
2"	128	115	141	50	300	F05	16,5	26	12	4xM6	M18x1,5	7,7	75

Dimensions in mm, weight in kg and Torque in Nm.
Weights and dimensions can be changed without notice.

ASME 81500

Class 1500

Full Bore

Class 1500. From 1/4" to 2"

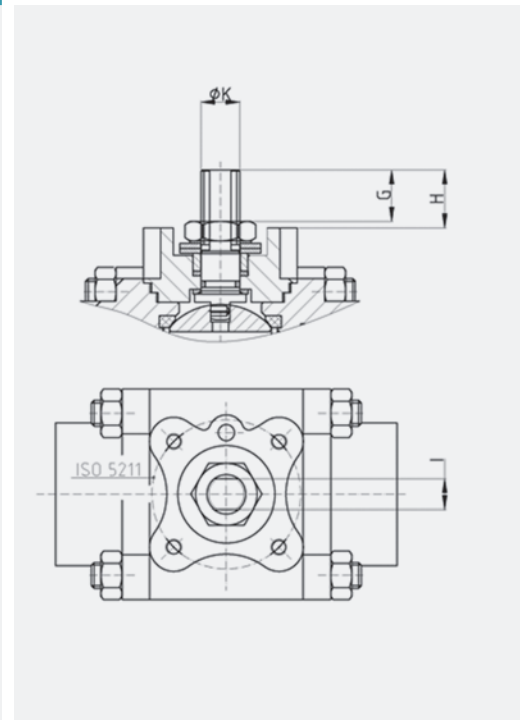
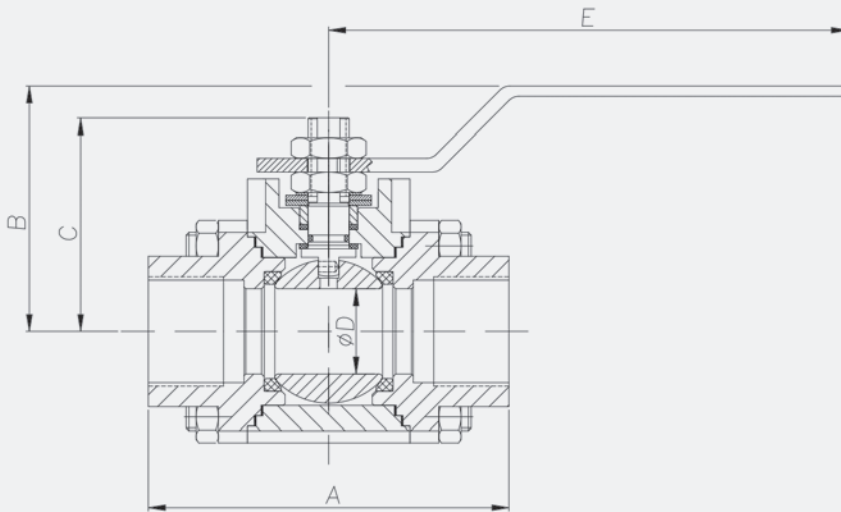

Pressure - Temperature

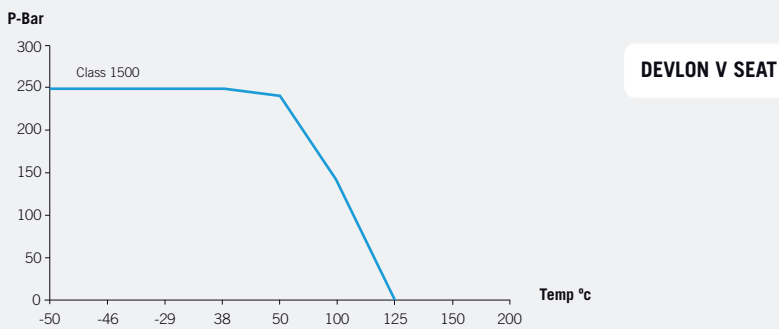

Fig. 81500 (Class 1500)

DN	A	B	C	ØD	E	ISO 5211	G	H	I	N° x J	ØK	WEIGHT	TORQUE
3/8"	84	59	69,4	9,5	170	F03	9,7	10,4	7	4xM5	10	2,2	14
1/2"	104	66	76,4	15	170	F03	9,7	10,4	9	4xM5	12	3,2	20
3/4"	127	86	103,7	20	245	F05	15,6	17,7	9,5	4xM6	16	5,8	29
1"	134	91	108	25	245	F05	15,4	17	9,5	4xM6	16	7	43
1 1/2"	200	111	128,6	40	350	F07	16	17,6	16	4xM8	22	17	131
2"	222	142	162,4	49	375	F07	19	20,4	16	4xM8	25	24	203

Dimensions in mm, weight in kg and Torque in Nm.
Weights and dimensions can be changed without notice.

| BALL VALVES |

MONOBLOCK VALVES

3/8" - 2" | Class 800 - Class 1500



Materials MONOBLOCK

Item	Description	L.I.CG.	L.I.CG.
1	Body	A 350 Gr. LF2 Class 1	A 479 Tp.316L
2	Body connector	A 350 Gr. LF2 Class 1	A 479 Tp.316L
3	Ball		A 351 Gr. CF8M / A182 F316
4	Stem		AISI 410 / A 479 Tp.316
5	Seat ring		Carbon graphite filled PTFE
6	Wrench (DN-1½" & 2")		Nodular iron
6.1	Wrench (DN-3/8" ~ 1")		AISI-316
7	Gland nut		AISI 303
8	Disk spring		E.N.P. Carbon Steel
9	Stop plate (DN-1½" & 2")		AISI 304
10	Gland		AISI 316
11	Gland packing		Graphite
12	Stem thrust seal		25% G.F. PTFE
14	Stop pin		Stainless St.
16	Bolt (DN-1½" & 2")		DIN 933 A2
17	Washer (DN-1½" & 2")		AISI 304
18	Thrust washer		25% G.F. PTFE
19	Antistatic device		Stainless St.
41	Spacer (DN-40 & 50)		AISI 304
72	"O" Ring		FKM
89	Identification plate		Stainless St.

ASME 400

Class 800

Full Bore

Class 800. From 3/8" to 2"

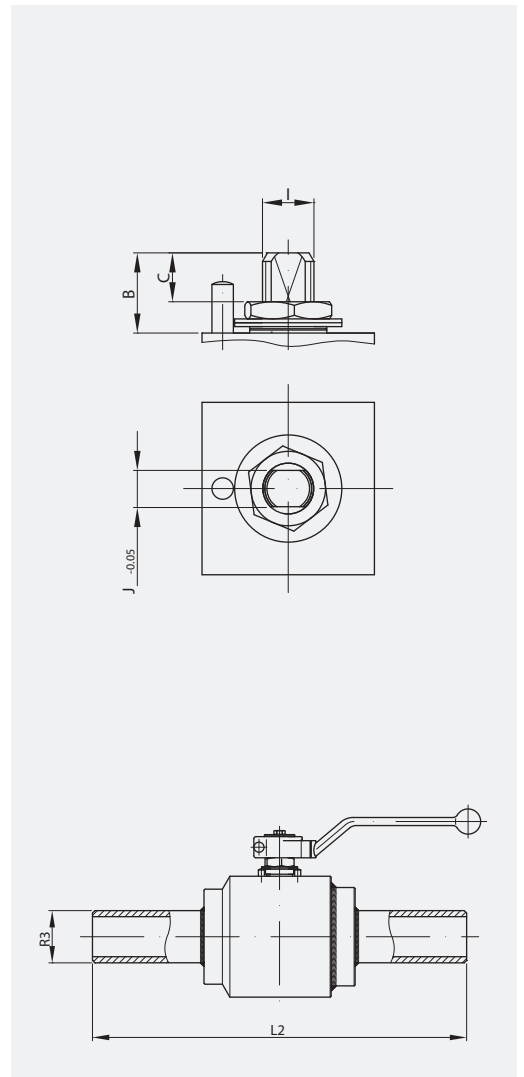
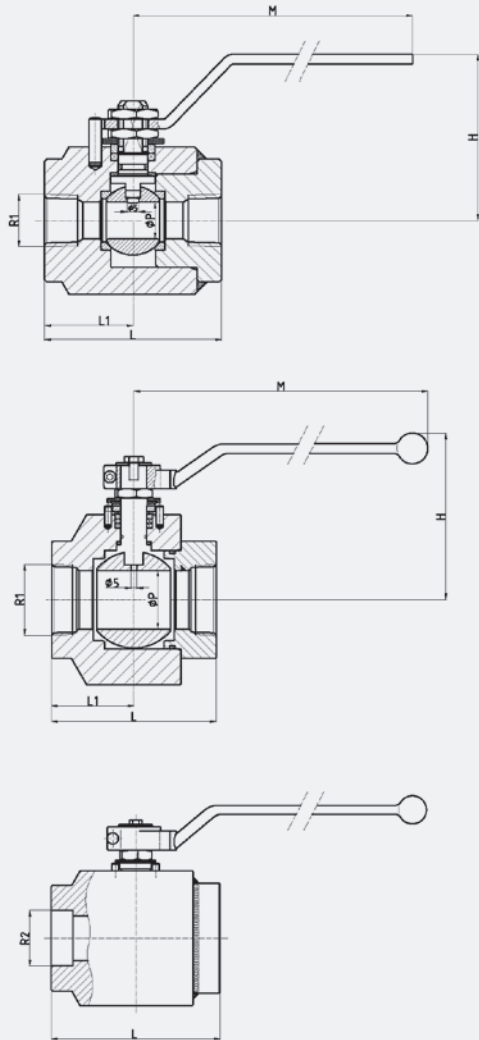

(*) Dimensions of diameters of drills ISO 5211 refer to table from page 60.

Pressure - Temperature

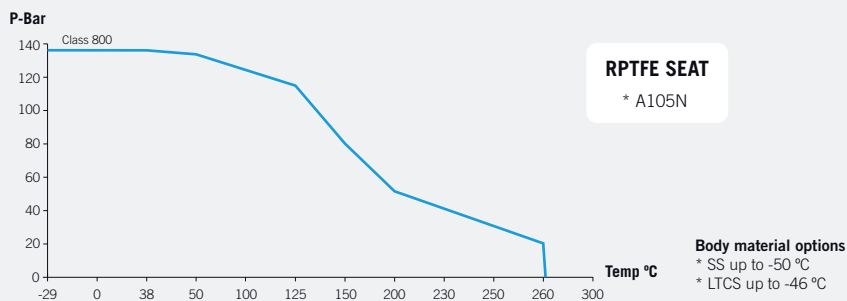

Fig. 400 (Class 800)

DN	øP	L	L2	R1	R2	R3	H	M	B	C	I	J	WEIGHT	TORQUE 20 bar	TORQUE 55 bar	TORQUE 138 bar
3/8"	9,5	70	240	3/8" NPT	3/8" SW	3/8" BW	87	159	16	8,5	M10x1.5	7	1	6	9	11
1/2"	15	72	240	1/2" NPT	1/2" SW	1/2" BW	92	159	18,7	10,8	M12x1.5	9	1,6	8	11	13
3/4"	20	90	240	3/4" NPT	3/4" SW	3/4" BW	94	159	19,2	11,3	M12x1.5	9	2,4	10	14	15
1"	25	95	240	1" NPT	1" SW	1" BW	98	159	19,7	11,3	M12x1.5	9	3,1	13	19	20
1 1/2"	40	130	260	1 1/2" NPT	1 1/2" SW	1 1/2" BW	128	213	38,5	19,1	M18x1.5	13	10	25	50	69
2"	50	140	260	2" NPT	2" SW	2" BW	141	348	41	18,9	M22x1.5	16	14,6	40	70	124

Dimensions in mm, weight in kg and Torque in Nm. Weights and dimensions can be changed without notice.

ASME 411N

Class 800

Reduced Bore

Class 800. From ½" to 2"

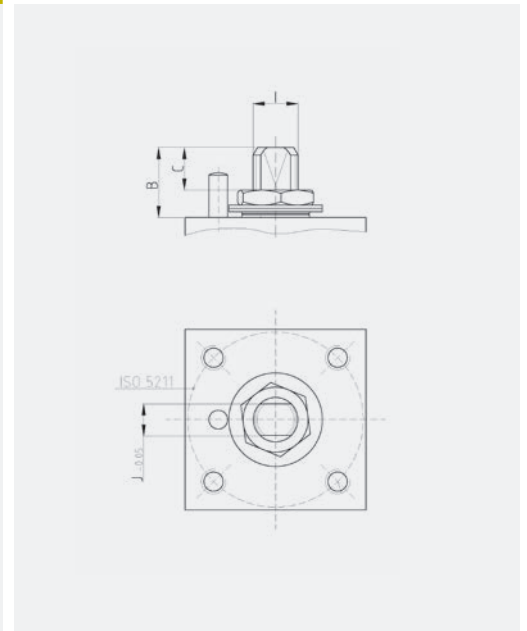
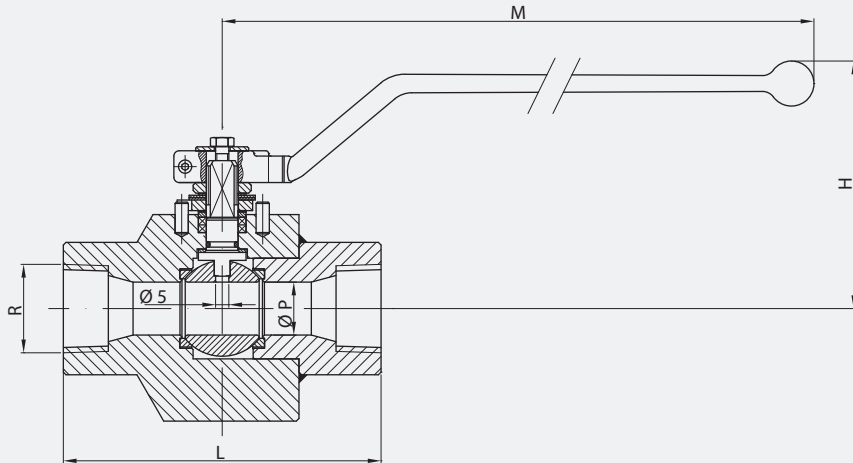

(*) Dimensions of diameters of drills ISO 5211 refer to table from page 60.

Pressure - Temperature

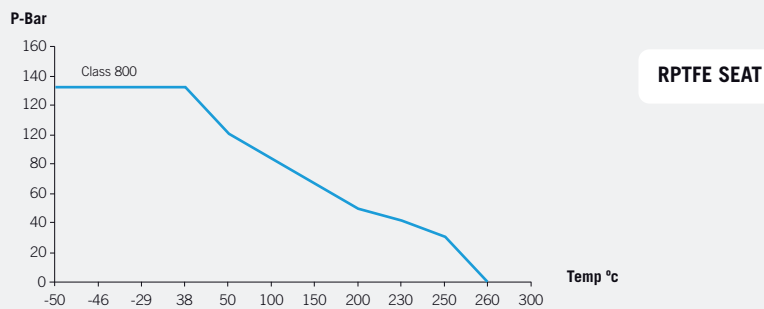

Fig. 411N (Class 800)

DN	ØP	L	R	H	M	B	C	I	J	WEIGHT	TORQUE 20 bar	TORQUE 55 bar	TORQUE 138 bar
½"	15	90	NPT	103	164	18,7	6,5	M12x1.5	9	3,5	7	10	16
¾" x ½"	15	110	NPT	103	164	18,7	6,5	M12x1.5	9	4,5	7	10	16
1" x ¾"	20	120	NPT	106	164	20	8	M12x1.5	9	5	9	14	25
1 ½" x 1"	28	150	NPT	112	210	31,5	14,8	M16x1.5	13	6	19	34	71
2" x 1 ½"	36	180	NPT	129	213	38,5	18,3	M18x1.5	13	10	43	79	164

Dimensions in mm, weight in kg and Torque in Nm.
Weights and dimensions can be changed without notice.

ASME 41500

Class 1500

Reduced & Full Bore

Class 1500. From 3/8" to 2"

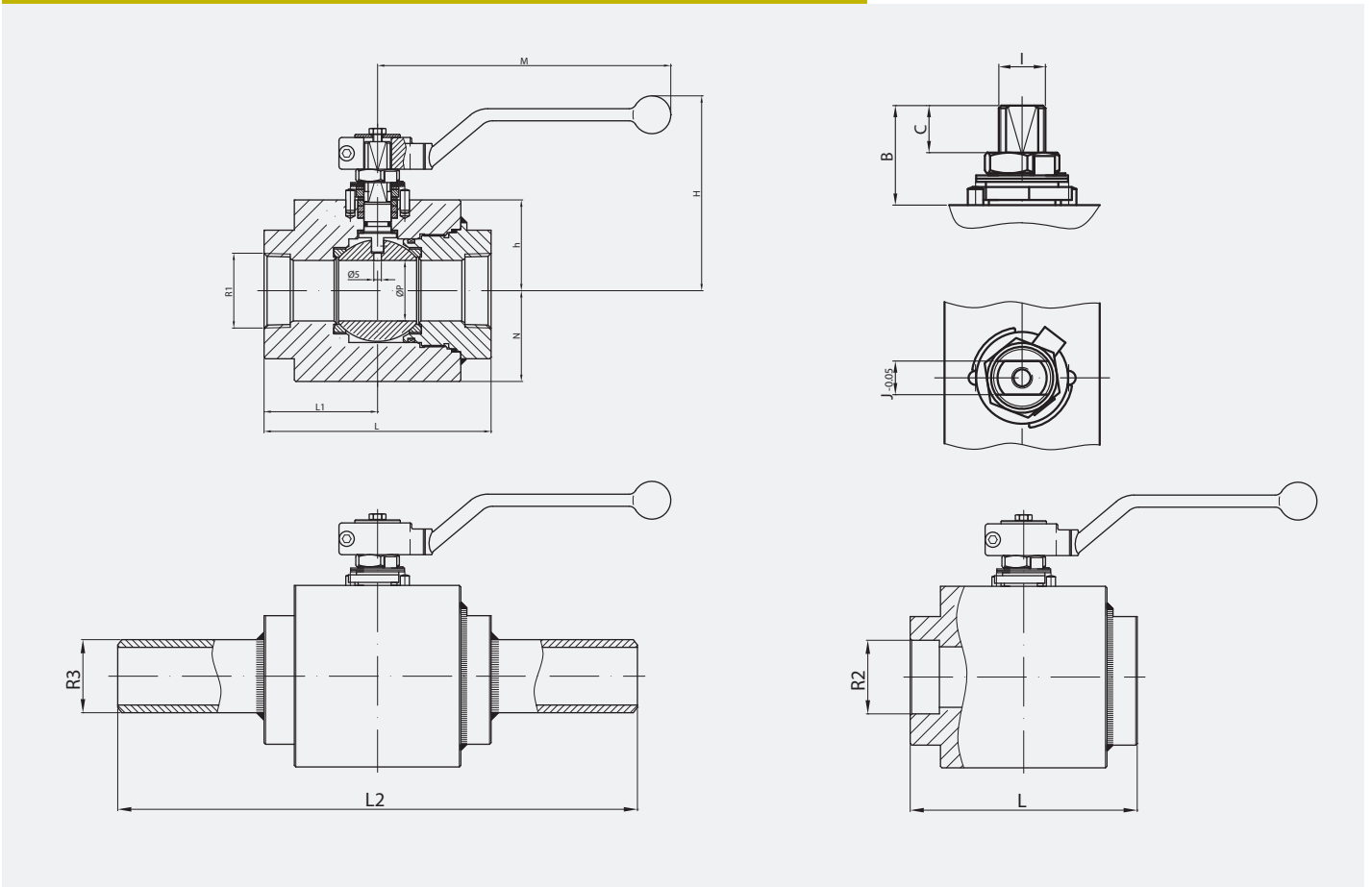

(*) Dimensions of diameters of drills ISO 5211 refer to table from page 60.

Pressure - Temperature

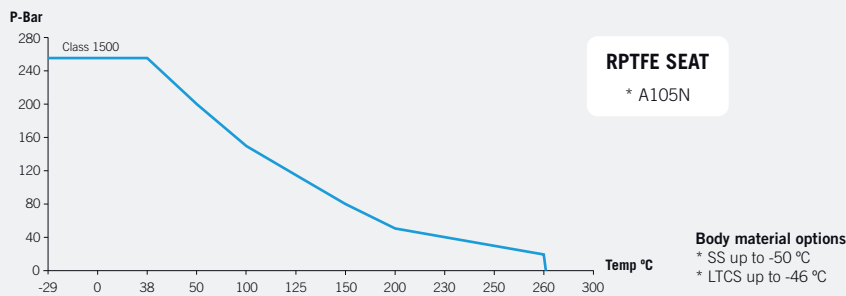

Fig. 41500 (Class 1500)

DN	ØP	L	L1	L2	R1	R2	R3	h	N	H	M	B	C	I	J	TORQUE
3/8"	9,5	80	35	240	3/8" NPT	3/8" SW	3/8" BW	25	25	81	164	16	5,7	M10x1,5	7	12
1/2" x 3/8"	9,5	90	35	250	1/2" NPT	1/2" SW	1/2" BW	25	25	81	164	16	5,7	M10x1,5	7	11
1/2"	15	90	35	250	1/2" NPT	1/2" SW	1/2" BW	29	30,5	100	164	19,7	7,5	M12x1,5	9	15
3/4" x 1/2"	15	110	50	270	3/4" NPT	3/4" SW	3/4" BW	29	30,5	100	164	19,7	7,5	M12x1,5	9	15
3/4"	20	110	50	270	3/4" NPT	3/4" SW	3/4" BW	32	34	103	164	19,7	7,5	M12x1,5	9	24
1" x 3/4"	20	119	49	279	1" NPT	1" SW	1" BW	32	34	103	164	19,7	7,5	M12x1,5	9	24
1"	25	119	49	279	1" NPT	1" SW	1" BW	36	37,5	107	164	19,7	7	M12x1,5	9	32
1 1/2" x 1.1/4"	32	150	75	310	1.1/2" NPT	1.1/2" SW	1.1/2" BW	36	37,5	116	210	30,5	14	M16x1,5	12	87
1 1/2"	40	150	75	310	1.1/2" NPT	1.1/2" SW	1.1/2" BW	60	60	129	213	38,5	18,3	M18x1,5	13	117
2 x 1 1/2"	40	161	66	321	2" NPT	2" SW	2" BW	60	60	129	213	38,5	18,3	M18x1,5	13	117
2"	50	161	66	321	2" NPT	2" SW	2" BW	73	73	142	348	40,5	18,1	M22x1,5	16	185

Dimensions in mm, weight in kg and Torque in Nm. Weights and dimensions can be changed without notice.

| BALL VALVES |

SEMI-TRUNNION BALL VALVES

8" - 12" | Class 150 - Class 300

DN 200 - DN 300 | PN 16 - PN 40

Materials CAST TRUNNION

Item	Description	AIT	IIT
1	Body	A 216 Gr. WCB (C ≤ 0,25%)	A 351 Gr. CF8M
2	Body connector	A 216 Gr. WCB (C ≤ 0,25%)	A 351 Gr. CF8M
3	Ball	A 351 Gr. CF8M	
4	Stem	A 479 Tp.316	
5	Seat ring	PTFE	PTFE
7	Gland nut	Zinc plated carbon steel	AISI 303
8	Disk spring	Carbon St.	E.N.P. Carbon St.
9	Stop plate	Carbon St.	AISI 304
10	Gland	AISI 303	AISI 316
10.1	Gland	AISI 303	AISI 316
11	Gland packing	Graphite	
12	Stem thrust seal	25% G.F. PTFE	
13	Body connector seal	AISI 316L + Graphite	
14	Stop pin	Carbon St.	Stainless St.
15	Stud	A 193 Gr. B7M Zinc dichromate	A 193 Gr. B8M
18	Thrust washer	25% G.F. PTFE	
19	Antistatic device	Stainless St.	
21 /21a	Ball Trunnion	AISI 316	
22 /22a	Trunnion Bearing	PTFE + 50% SS	
23	Bearing	PTFE	
26	Bolt	DIN 912 8.8 Zinc plated	DIN 912 A2
28	Nut	A 194 Gr. 2HM Zinc dichromate	A 194 Gr. 8M
39	Stem Bushing	25% G.F. PTFE *	
41	Spacer	Carbon St.	Stainless St.
43	Key	AISI 316	
46	Locking washer	AISI 304	
47	Key	AISI 316	
58	Spring Protection	Carbon St.	Stainless St.
72	O Ring	FKM	
89	Identification plate	Stainless St.	
471	Retainer	Steel	Stainless St.

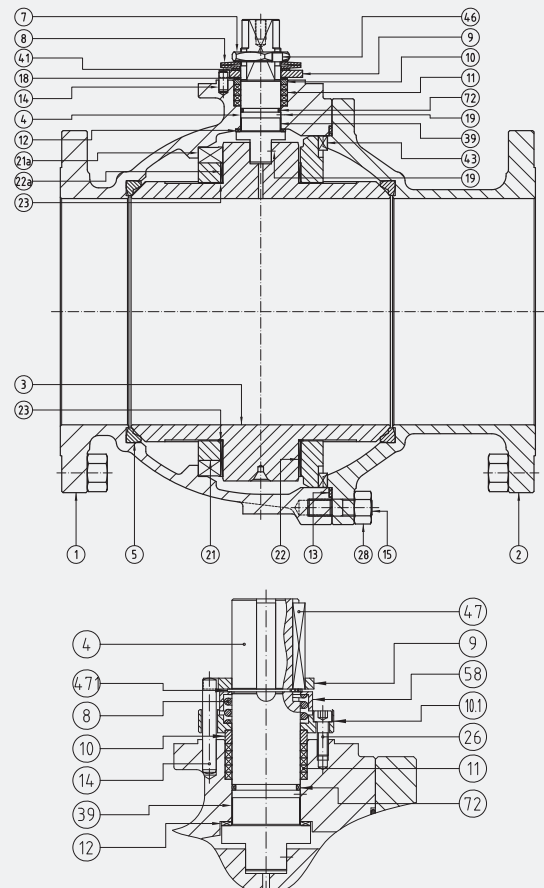

(*) AISI 316 + PTFE only in DN300 (12").

ASME 1515 / 1530

Class 150 / 300

Full Bore

Class 150. From 10" to 12"

Class 300. From 8" to 12"

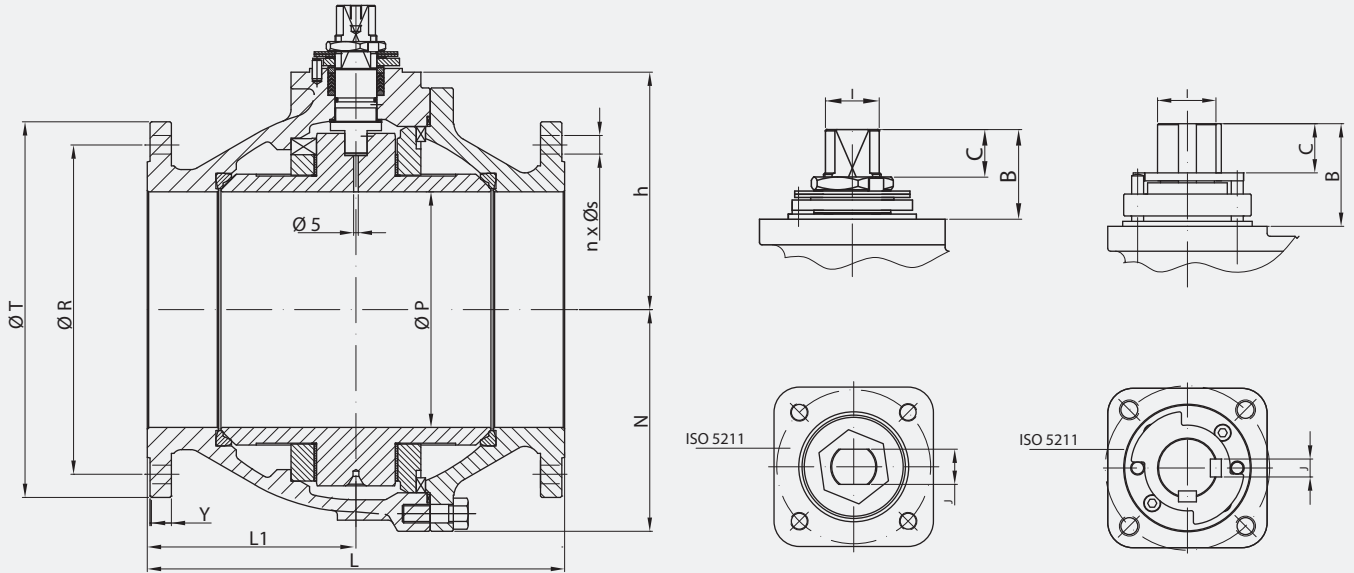

(*) Dimensions of diameters of drills ISO 5211 refer to table from page 60.

Pressure - Temperature

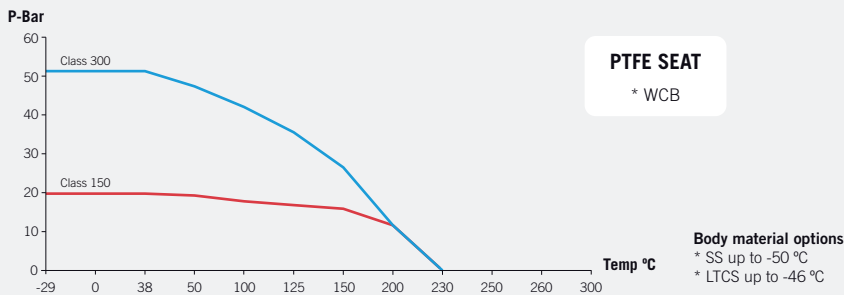

Fig. 1515 (Class 150)

DN	øP	L	L1	øR	n x øS	Y	øT	h	N	ISO 5211	B	C	I	J	WEIGHT	TORQUE	Kv
250 (10")	254	533	225	362	12x25,4	28,6	405	256	239	F14	72	36,5	M45x2	32	237	1.280	15.000
300 (12")	305	610	245	431,8	12x25,4	30,2	485	297	288	F14	106	58	ø50	14	357	1.500	20.800

Fig. 1530 (Class 300)

DN	øP	L	L1	øR	n x øS	Y	øT	h	N	ISO 5211	B	C	I	J	WEIGHT	TORQUE	Kv
200 (8")	203	502	239	330,2	12x25,4	39,7	380	233	208	F14	72	36,5	M45x2	32	189	1.100	9.000
250 (10")	254	568	225	387,4	16x28,6	46,1	445	256	253	F14	72	36,5	M45x2	32	301	1.480	15.000
300 (12")	305	648	315	450,8	16x31,8	49,3	520	310	300	F16	103	49,4	ø60	18	520	1.900	20.800

Dimensions in mm, weight in kg and Torque in Nm.
Weights and dimensions can be changed without notice.

EN-DIN 1516 / 1540

PN 16 / PN 40

Full Bore

PN 16. From DN 250 to DN 300

PN 40. From DN 200 to DN 300

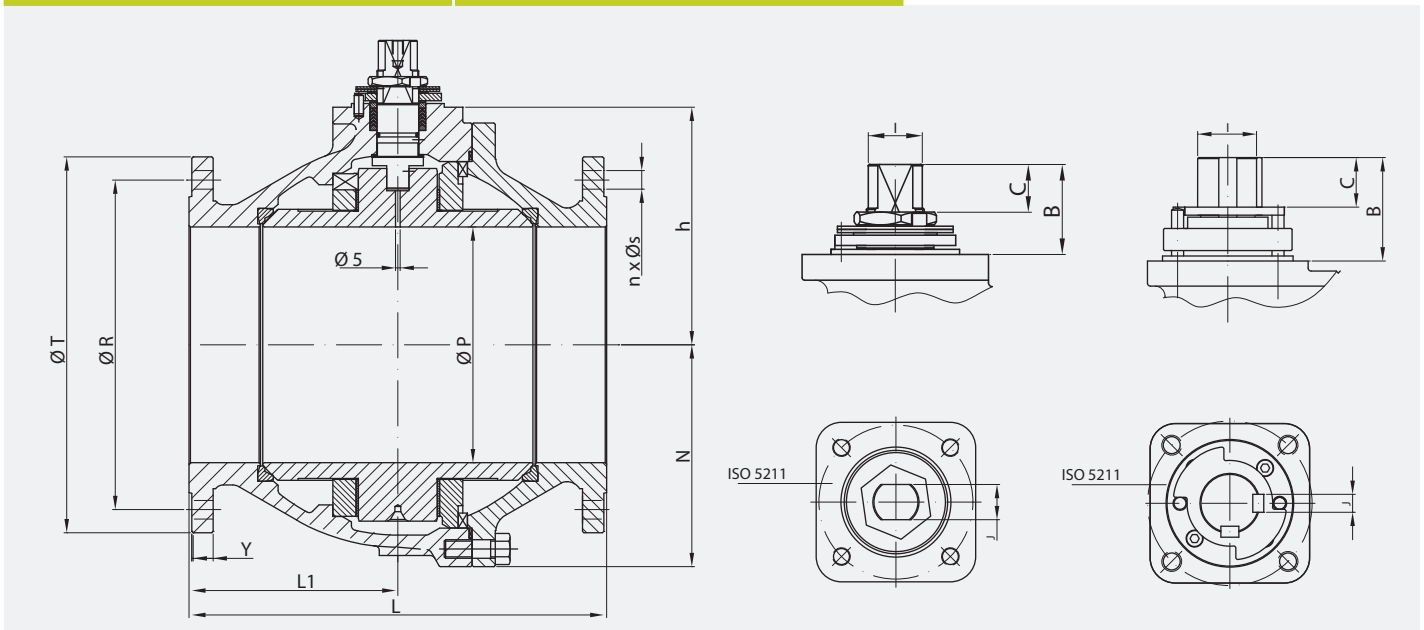

Pressure - Temperature

(*) Dimensions of diameters of drills ISO 5211 refer to table from page 60.
(**) Only DN300

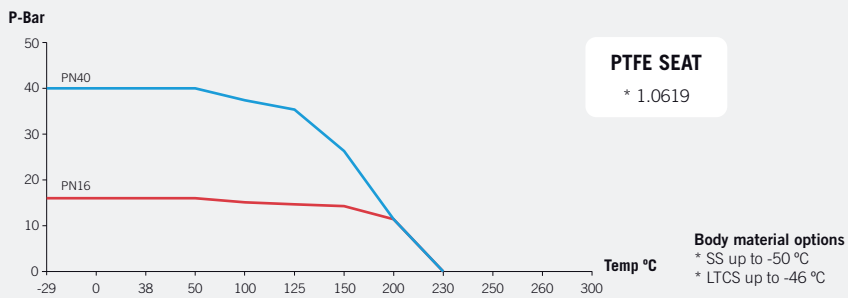

Fig. 1516 (PN 16)

DN	ØP	L	L1	ØR	n x ØS	Y	ØT	h	N	ISO 5211	B	C	I	J	WEIGHT	TORQUE	Kv
250 (10")	254	450	225	355	12x26	26	405	256	239	F14	72	36,5	M45x2	32	223	1.120	15.000
300 (12")	305	500	245	410	12x26	28	460	297	288	F14	106	58	Ø50	14	323	1.500	20.800

Fig. 1540 (PN 40)

DN	ØP	L	L1	ØR	n x ØS	Y	ØT	h	N	ISO 5211	B	C	I	J	WEIGHT	TORQUE	Kv
200 (8")	203	400	200	320	12x30	34	375	233	208	F14	72	36,5	M45x2	32	162	1.020	9.000
250 (10")	254	450	199	385	12x33	38	450	256	253	F14	72	36,5	M45x2	32	264	1.400	15.000
300 (12")	305	500	240	450	16x33	42	515	310	300	F16	103	49,4	Ø60	18	440	1.860	20.800

Dimensions in mm, weight in kg and Torque in Nm.
Weights and dimensions can be changed without notice.



The quality option

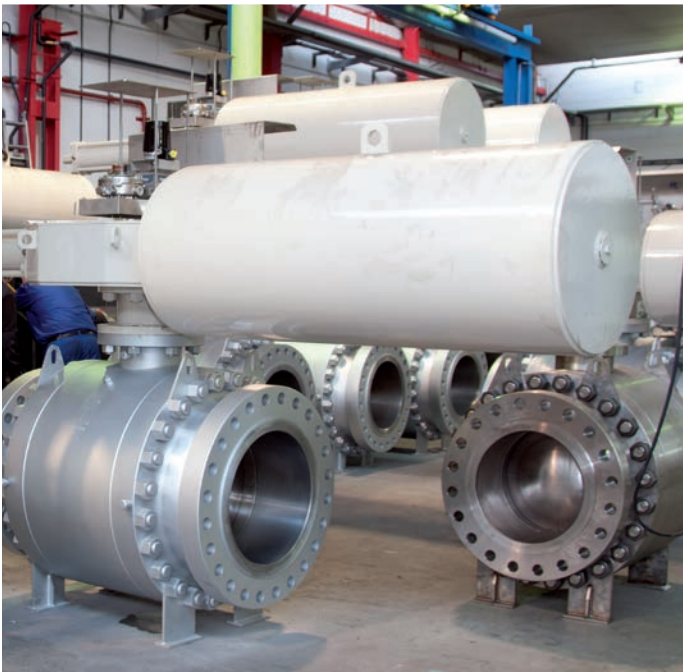

| BALL VALVES |

FLOATING EN-DIN

DN 15 - DN 200 | PN 16 - PN 40

A floating ball valve is a valve with seats supported ball, that is pushed by upstream pressure towards the downstream seat to ensure sealing. The DN of the floating ball valves range is limited by the capability of the seats material to support the pressure, temperature and weight of the ball.

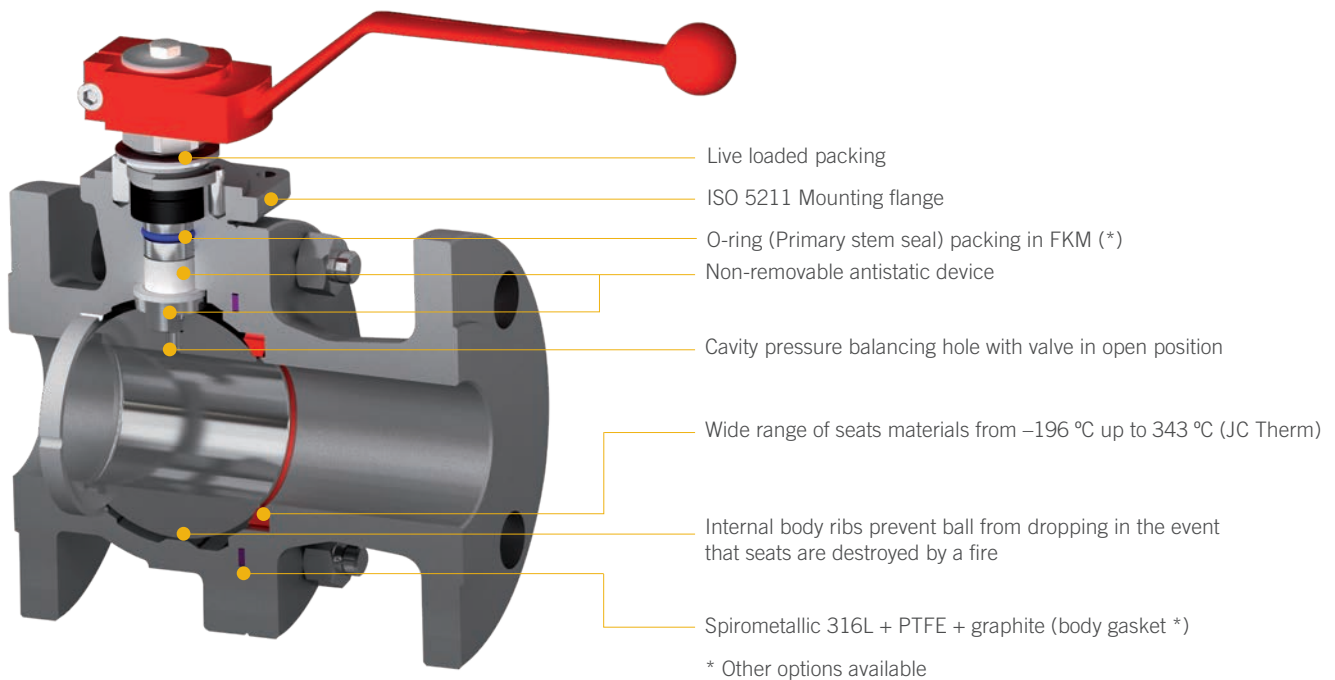

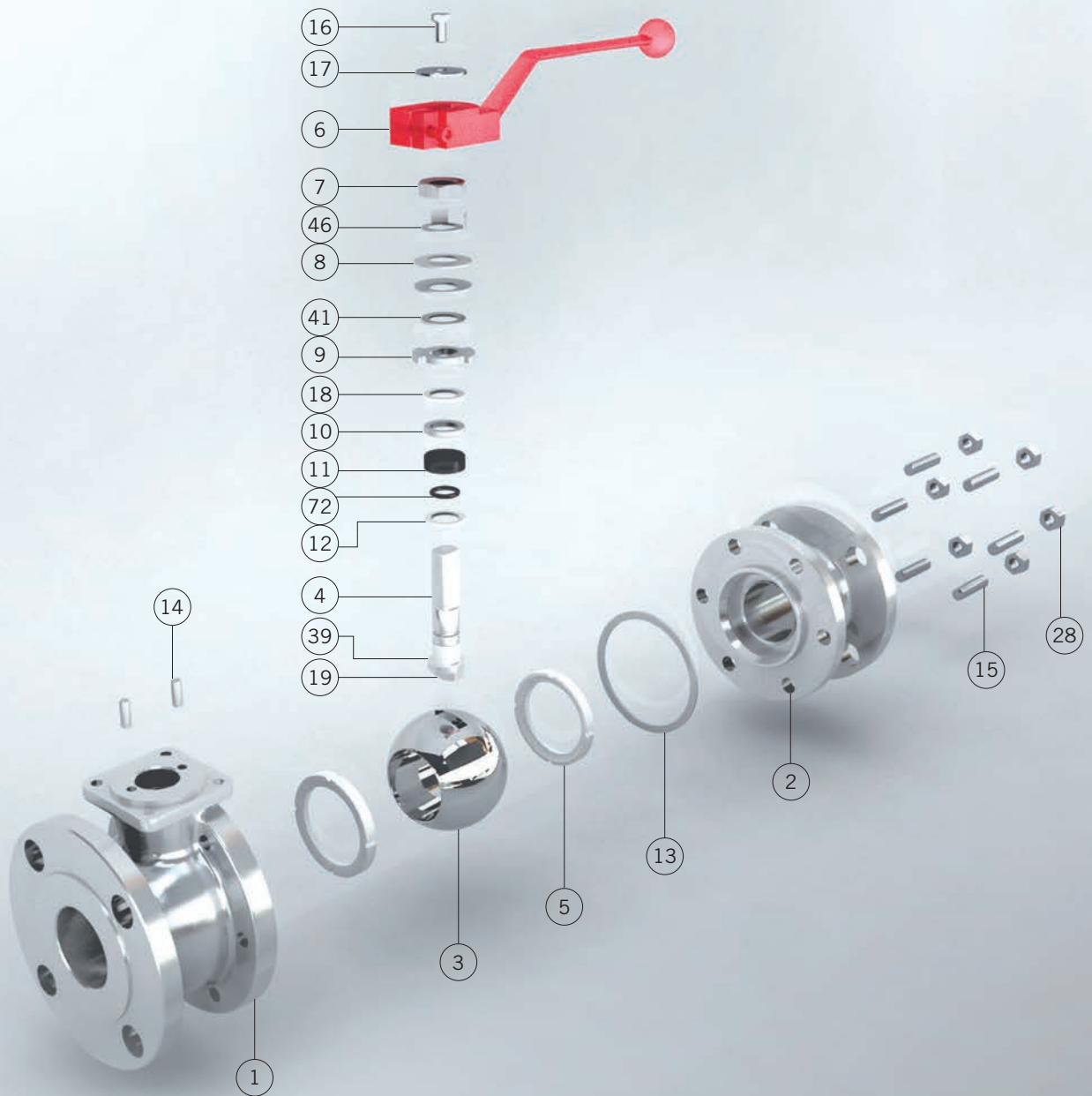

Materials EN-DIN

Item	Description	AIT	IIT
1	Body	1.0619	1.4408
2	Body connector	1.0619	1.4408
3	Ball	A 351 Gr. CF8M (DN 15 : 50 A 479 Tp.316)	
4	Stem	A 479 Tp.316	
5	Seat ring	PTFE	
6	Wrench	Nodular Iron	
7	Gland nut	Zinc plated carbon steel	AISI 303
8	Disk spring	Carbon St.	A 666 Tp.301
9	Stop plate	Carbon St.	AISI 304
10	Gland	AISI 303	AISI 316
11	Gland packing	Graphite	
12	Stem thrust seal	25% G.F. PTFE	
13	Body connector seal	AISI 316L + PTFE + Graphite	
14	Stop pin	Carbon St.	Stainless St.
15	Bolt (DN 32 to DN 100 Stud)	8.8 Zinc Plated & Bichromated	A4-70
16	Bolt	DIN 933 A4-70	
17	Washer	Zinc plated carbon steel	AISI 304
18	Thrust washer	25% G.F. PTFE	
19	Antistatic device	Stainless St.	
28	Nut (DN 32 to DN 100)	DIN 934 .8 Zinc Plated & Bichromated	DIN 934 A4-70
39	Stem bushing (DN 25 to DN 200)	25% G.F. PTFE	
41	Spacer (DN 40 to 200)	Carbon St.	AISI 304
46	Washer	AISI 304	AISI 304
72	"O" Ring	FKM	
89	Identification plate	Stainless St.	

EN-DIN 516 / 540

PN 16 / 40

Full Bore

PN 16. From DN 65 to DN 200

PN 40. From DN 15 to DN 150

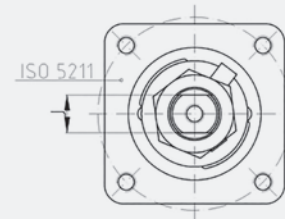
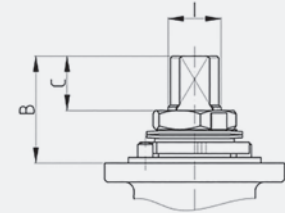
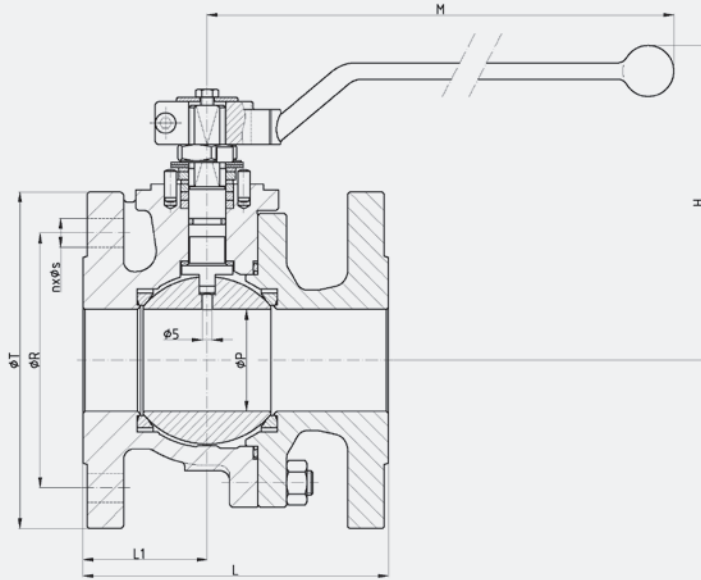

Pressure - Temperature

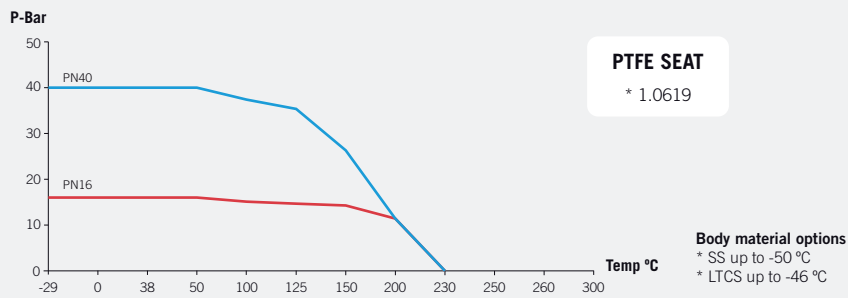

(*) Dimensions of diameters of drills ISO 5211 refer to table from page 60.



Fig. 516 (PN 16)

DN	ØP	L	L1	ØR	n x ØS	ØT	H	M	ISO 5211	B	C	I	J	WEIGHT	TORQUE	Kv
65	65	170	75,5	145	4x18	185	169	348	F07	44	18,6	M22x1,5	16	16	61	550
80	80	180	82	160	8x18	200	207	445	F10	44,5	18,6	M25x1,5	18	22	97	1.000
100	100	190	90,5	180	8x18	220	232	495	F10	56,5	27,8	M28x1,5	20	32	133	1.650
125	125	325	120	210	8x18	250	265	698	F12	56	24,8	M35x2	25	52,5	226	3.000
150	151	350	135	240	8x22	285	298	698	F12	68	37,1	M40x2	29	76	320	4.200
200	203	400	200	295	12x22	340	353	868	F14	72	36,5	M45x2	32	111	694	9.000

Fig. 540 (PN 40)

DN	ØP	L	L1	ØR	n x ØS	ØT	H	M	ISO 5211	B	C	I	J	WEIGHT	TORQUE	Kv
15	15	115	53	65	4x14	95	111	164	F05	11,2	5	M12x1,5	9	2,8	11	20
20	20	120	52	75	4x14	105	118	164	F05	14,7	8,5	M12x1,5	9	3,6	14	20
25	25	125	48,5	85	4x14	115	130	164	F05	22,7	9,5	M12x1,5	9	5	20	75
32	32	130	54	100	4x18	140	131	210	F05	32	13	M16x1,5	12	7	25	130
40	40	140	55	110	4x18	150	148	213	F07	41,5	18,3	M18x1,5	13	9	33	170
50	50	150	61	125	4x18	165	155	213	F07	41,5	18,3	M18x1,5	13	12	46	270
65	65	170	75,5	145	8x18	185	169	348	F07	44	18,6	M22x1,5	16	17	66	550
80	80	180	74,5	160	8x18	200	207	445	F10	44,5	18,6	M25x1,5	18	23	116	1.000
100	100	190	91	190	8x22	235	232	495	F10	56,5	27,8	M28x1,5	20	35	171	1.650
125	125	325	120	220	8x26	270	265	698	F12	56	24,8	M35x2	25	57	283	3.000
150	151	350	135	250	8x26	300	298	698	F12	68	37,1	M40x2	29	83,5	463	4.200

Dimensions in mm, weight in kg and Torque in Nm.
Weights and dimensions can be changed without notice.

EN-DIN 316 / 340

PN 16 / 40

Full Bore

PN 16. From DN 65 to DN 150

PN 40. From DN 15 to DN 150

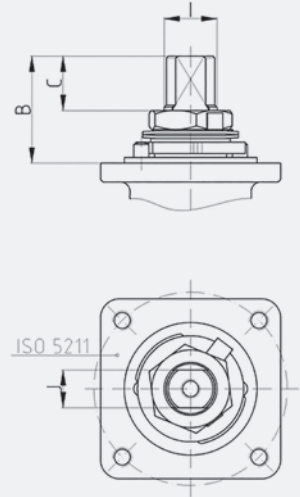
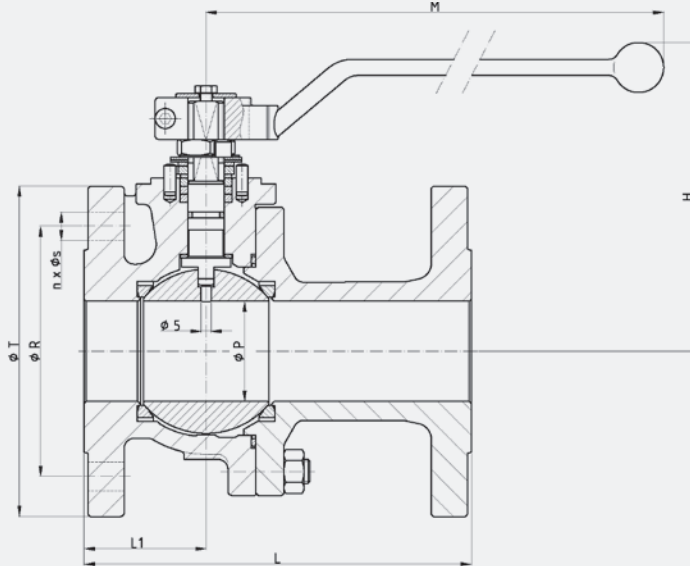

(*) Dimensions of diameters of drills ISO 5211 refer to table from page 60.

Pressure - Temperature

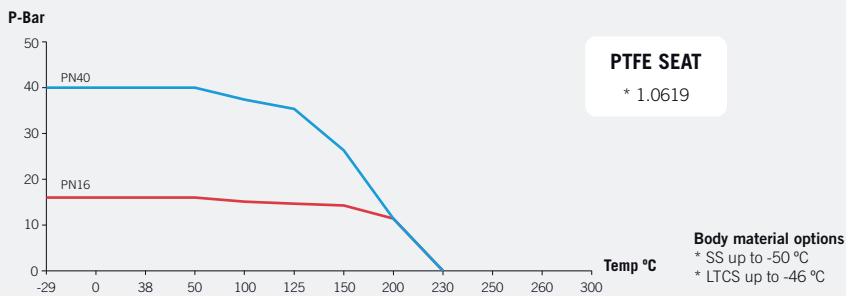

Fig. 316 (PN 16)

DN	ØP	L	L1	ØR	n x ØS	ØT	H	M	ISO 5211	B	C	I	J	WEIGHT	TORQUE	Kv
65	65	290	75,5	145	4x18	185	169	348	F07	44	18,6	M22x1,5	16	18,3	61	550
80	80	310	82	160	8x18	200	207	445	F10	44,5	18,6	M25x1,5	18	24	97	1.000
100	100	350	90,5	180	8x18	220	232	495	F10	56,5	27,8	M28x1,5	20	36	133	1.650
125	125	400	120	210	8x18	250	265	698	F12	56	24,8	M35x2	25	58	226	3.000
150	151	480	135	240	8x22	285	298	698	F12	68	37,1	M40x2	29	81	320	4.200
200	203	600	200	295	12x22	340	353	868	F14	72	36,5	M45x2	32	-	694	-

Fig. 340 (PN 40)

DN	ØP	L	L1	ØR	n x ØS	ØT	H	M	ISO 5211	B	C	I	J	WEIGHT	TORQUE	Kv
15	15	130	53	65	4x14	95	111	164	F05	11,2	5	M12x1,5	9	3	11	20
20	20	150	52	75	4x14	105	118	164	F05	14,7	8,5	M12x1,5	9	3,8	14	40
25	25	160	48,5	85	4x14	115	130	164	F05	22,7	9,5	M12x1,5	9	5,2	20	75
32	32	180	54	100	4x18	140	131	210	F05	32	13	M16x1,5	12	7,6	25	130
40	40	200	55	110	4x18	150	148	213	F07	41,5	18,3	M18x1,5	13	9,6	33	170
50	50	230	61	125	4x18	165	155	213	F07	41,5	18,3	M18x1,5	13	12,9	46	270
65	65	290	75,5	145	8x18	185	169	348	F07	44	18,6	M22x1,5	16	18,5	66	550
80	80	310	74,5	160	8x18	200	207	445	F10	44,5	18,6	M25x1,5	18	25	116	1.000
100	100	350	91	190	8x22	235	232	495	F10	56,5	27,8	M28x1,5	20	39	171	1.650
125	125	400	120	220	8x26	270	265	698	F12	56	24,8	M35x2	25	63	283	3.000
150	151	480	135	250	8x26	300	298	698	F12	68	37,1	M40x2	29	87	463	4.200

Dimensions in mm, weight in kg and Torque in Nm.
Weights and dimensions can be changed without notice.

EN-DIN 512

PN 16

Full Bore

PN 16. From DN 15 to DN 200

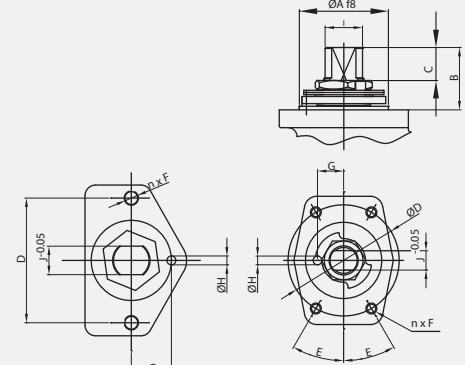
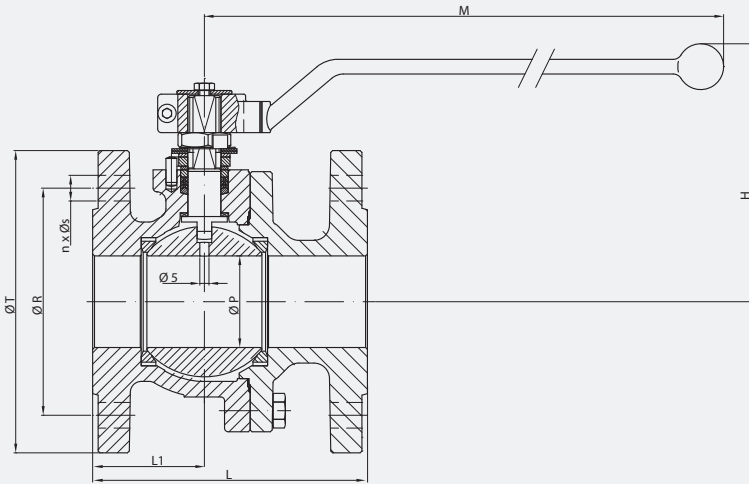

ONLY DN 15, DN 20 & DN 25

Pressure - Temperature

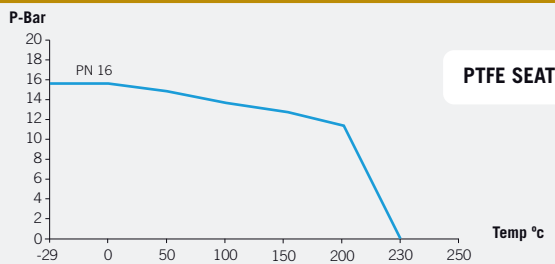

Fig. 512 (PN 16)

DN	ØP	L	L1	ØR	N x ØS	ØT	H	M	WEIGHT	TORQUE	Kv
15	15	115	50	65	4x14	95	99	164	2,4	8	20
20	20	120	52	75	4x14	105	102	164	3,2	10	40
25	25	125	52	85	4x14	115	106	164	3,9	15	75
32	32	130	54	100	4x18	140	117	210	6,3	22	130
40	40	140	55	110	4x18	150	133	213	8	25	170
50	50	150	61	125	4x18	165	141	213	10,7	40	270
65	65	170	75	145	4x18	185	152	348	15,4	55	550
80	80	180	78,5	160	8x18	200	189	445	20,2	85	1.000
100	100	190	90	180	8x18	220	220	495	25,8	130	1.650
125	125	325	141	210	8x18	250	254	698	49,5	180	3.000
150	150	350	160	240	8x22	285	281	698	74,1	250	4.200
200	200	400	200	295	12x22	340	338	868	110,5	580	9.000

ACTUATOR CONNECTION

DN	ØA	B	C	D	E	N x F	G	ØH	I	J
15	29	20	8,5	40	-	2xM6	13,3	5	M12x1.5	9
20	29	20	8,5	40	-	2xM6	13,3	5	M12x1.5	9
25	29	20	8,5	40	-	2xM6	13,3	5	M12x1.5	9
32	34	30	13	Ø50	30°	4xM6	15	5	M16x1.5	12
40	39	40,5	20	Ø56	30°	4xM10	18	6	M18x1.5	13
50	39	40,5	20	Ø56	30°	4xM10	18	6	M18x1.5	13
65	47	41	18,5	Ø65	30°	4xM10	22	6	M22x1.5	16
80	55	41,5	18,5	Ø74	30°	4xM10	24	8	M25x1.5	18
100	59	53,5	28,2	Ø82	30°	4xM10	26	8	M28x1.5	20
125	68	53	27,5	Ø100	40°	4xM12	30	8	M35x2	25
150	74	65	38,5	Ø104	40°	4xM12	33	8	M40x2	29
200	94	66	37	Ø130	40°	4xM16	42	10	M45x2	32

Dimensions in mm, weight in kg and Torque in Nm.
Weights and dimensions can be changed without notice.

JC
VALVES

The quality option

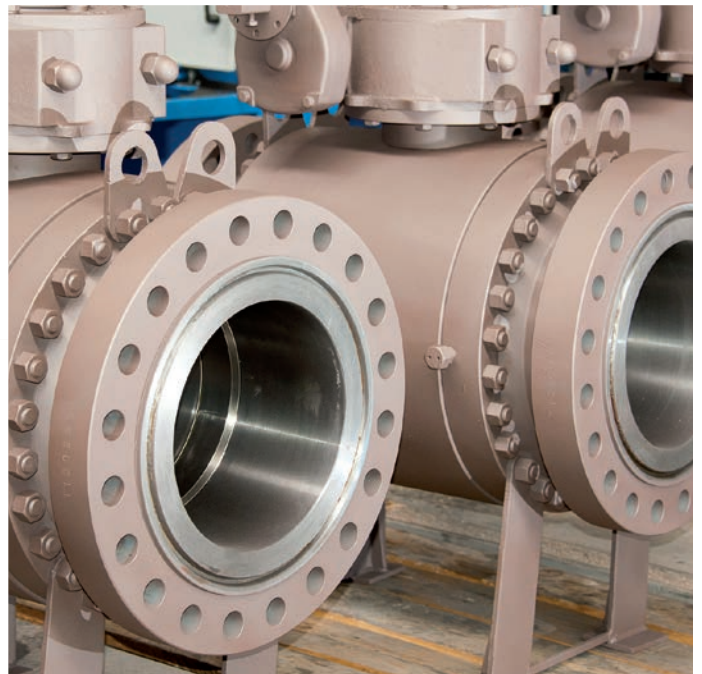
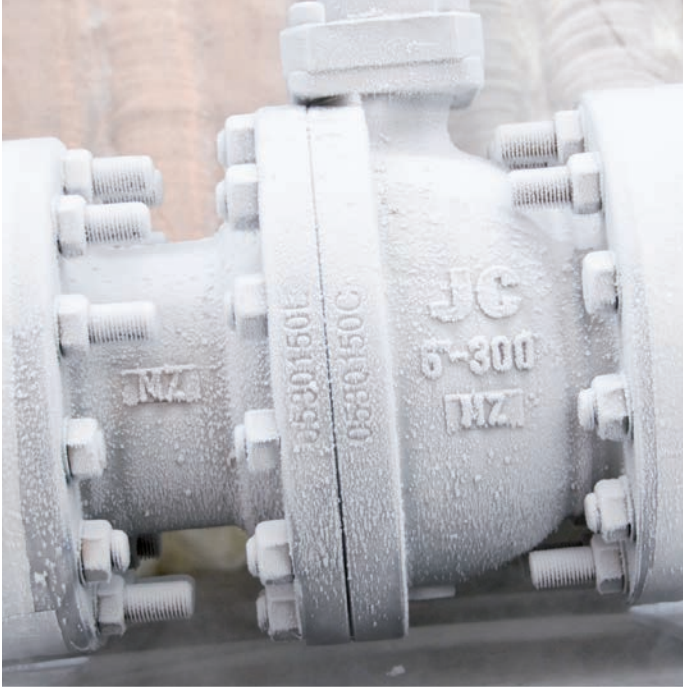

| BALL VALVES |

FLOATING 3 WAY BALL VALVES

1" - 8" | Class 150

DN 25 - DN 200 | PN 16

The JC Three way ball valves, have been designed to divert the flow at 90° in several options between two pipes. Three way ball valves are available with either "L" and double "L" (X) port, or T-port design. The full port design is easily automated and is available with various seat materials.



PORT COMBINATIONS

3 WAY L PORT

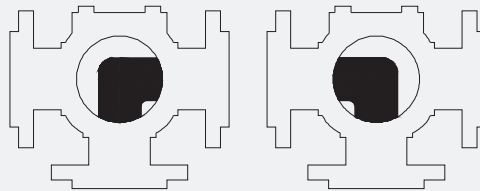

3 WAY T PORT

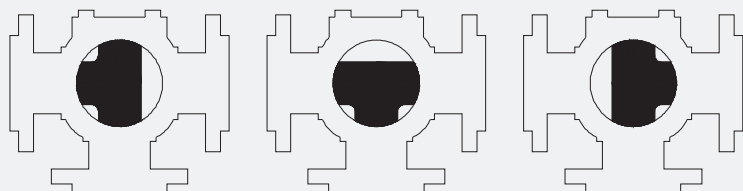

3 WAY INVERTED PORT

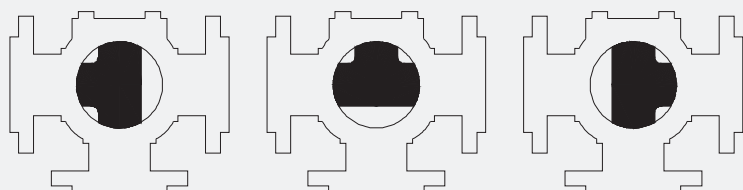

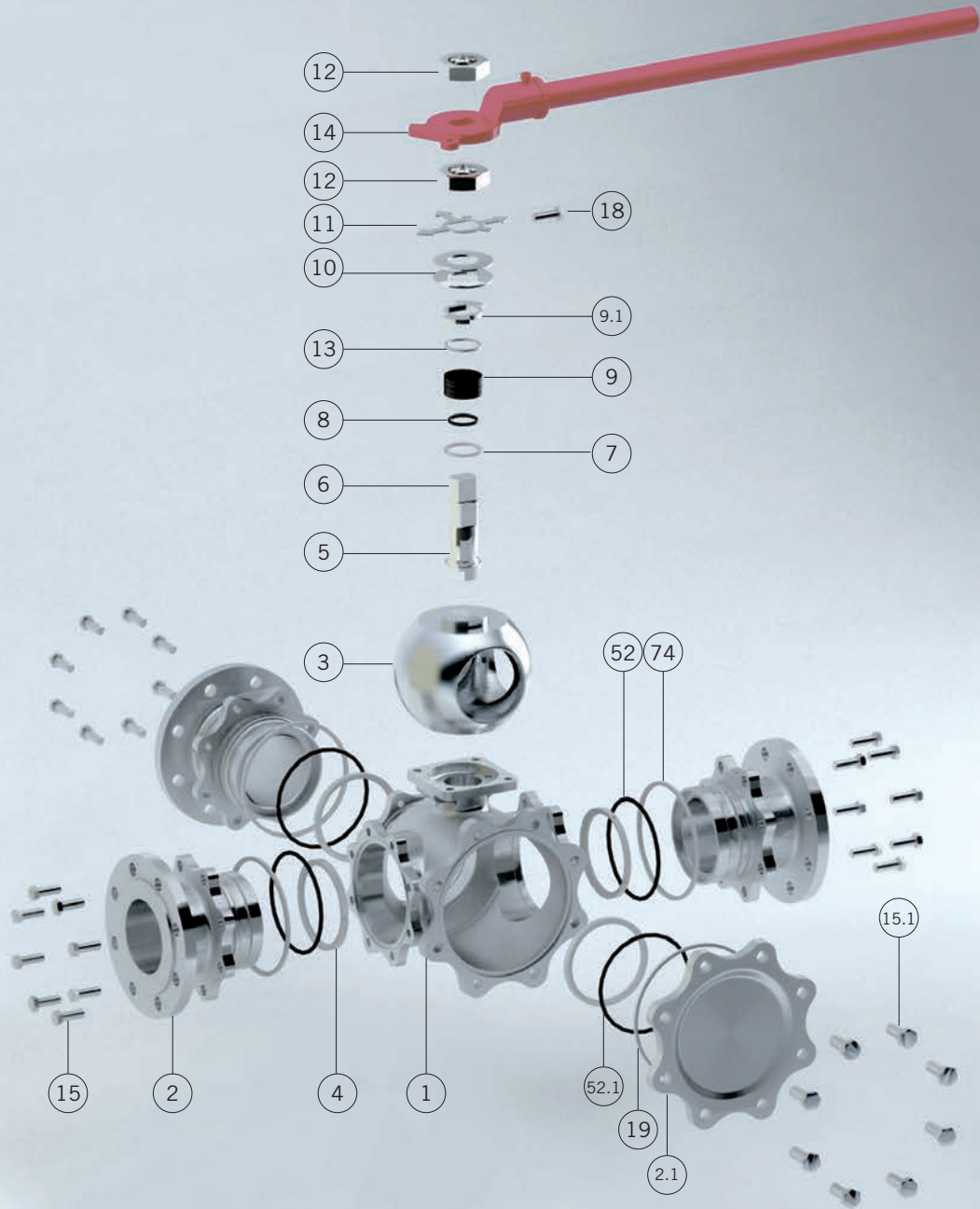

Materials

EN-DIN

ASME

916 AIT

916 IIT

915 AIT

915 IIT

Item	Description	Material		Material	
1	Body	1.0619	1.4408	A216 Gr. WCB (C _s ≤0,25%)	A351 Gr. CF8M
2	Body connector	1.0619	1.4408	A216 Gr. WCB (C _s ≤0,25%)	A351 Gr. CF8M
2.1	Side Cover	1.0619	1.4408	A216 Gr. WCB (C _s ≤0,25%)	A351 Gr. CF8M
3	Ball	A 351 Gr. CF8M		A 351 Gr. CF8M	
4	Seat ring	PTFE		PTFE	
5	Stem	A 479 Type 316		A 479 Type 316	
6	Stem thrust seal	25%GF PTFE		25%GF PTFE	
7	O'ring	FKM		FKM	
8	Stem packing	Graphite		Graphite	
9	Gland	AISI 303	AISI 316	AISI 303	AISI 316
9.1	Stop plate	F114	AISI 304	F114	AISI 304
10	Disk spring	E.N.P Carbon steel		E.N.P Carbon steel	
11	Look. Wash. Pointer	Rilsan coated Carbon St.		Rilsan coated Carbon St.	
12	Gland nut	Zinc plated carbon steel	AISI 303	Zinc plated carbon steel	AISI 303
13	Antifriction washer	25%GF. PTFE		25%GF. PTFE	
14	Wrench	Nodular iron		Nodular iron	
15	Bolt	DIN 933 A4 - 70		DIN 933 A4 - 70	
15.1	Bolt	DIN 933 A4 - 70		DIN 933 A4 - 70	
18	Stop bolt	A4-70		A4-70	
19	Body cover seal	PTFE		PTFE	
52	O'ring	FKM		FKM	
52.1	O'ring	FKM		FKM	
74	Body connector seal	PTFE		PTFE	
89	Identification plate	Stainless St.		Stainless St.	

ASME 915

Class 150

Full Bore

Class 150. From 1" to 8"

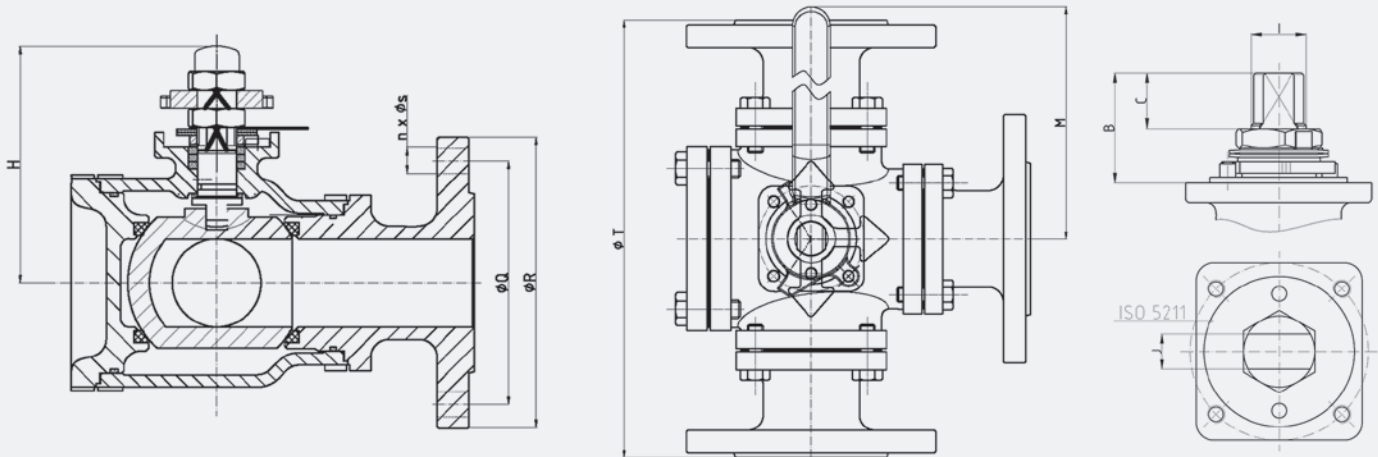

Pressure - Temperature

(*) Dimensions of diameters of drills ISO 5211 refer to table from page 60.

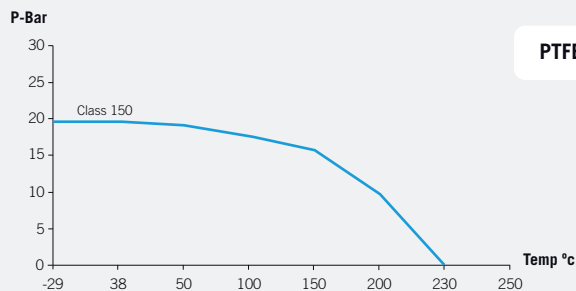
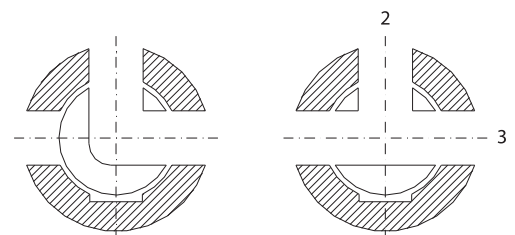

Fig. 915 (Class 150)

DN	φP	φL	A	A1	φR	n x φS	φT	H	M	ISO 5211	B	C	I	J	WEIGHT
1"	25	212	106	70	79,4	4x15,9	110	96	170	F05	22	12,2	M12x1,5	8	8
1½"	40	262	131	80	98,4	4x15,9	125	121	200	F07	33	19,2	M18x1,5	12	17
2"	50	290	145	90	120,7	4x19,1	150	134	350	F07	34	20,2	M22x1,5	15	25
2½"	65	325	162,5	107	139,7	4x19,1	180	180	350	F10	34	19,2	M22x1,5	15	34
3"	80	370	185	117	152,4	4x19,1	190	189	465	F10	45	27,7	M28x1,5	19	51
4"	100	430	215	148	190,5	8x19,1	230	230	475	F12	56	32,2	M36x1,5	24	77
6"	150	500	250	194	241,3	8x22,2	280	280	855	F14	69	41	M48x3	32	138
8"	200	600	300	270	298,5	8x22,2	345	325	855	F14	69	34	M48x3	32	214

TORQUE			Kv			
VALVE SIZE	AT MAXIMUM DIFFERENTIAL PRESSURE		VALVE SIZE	PORT L	PORT T	
	L	T			PORT 2	PORT 3
25 (1")	22	20	25 (1")	24	22	54
40 (1 ½")	65	55	40 (1 ½")	58	59	154
50 (2")	79	63	50 (2")	78	80	264
65 (2 ½")	140	108	65 (2 ½")	140	142	496
80 (3")	155	130	80 (3")	282	316	746
100 (4")	440	425	100 (4")	376	378	1.335
150 (6")	744	690	150 (6")	736	797	2.583
200 (8")	1.300	1.200	200 (8")	1.241	953	4.408



Dimensions in mm, weight in kg and Torque in Nm.
Weights and dimensions can be changed without notice.
Kv Values in m³/h.

EN-DIN 916

PN 16

Full Bore

PN 16. From DN 25 to DN 200

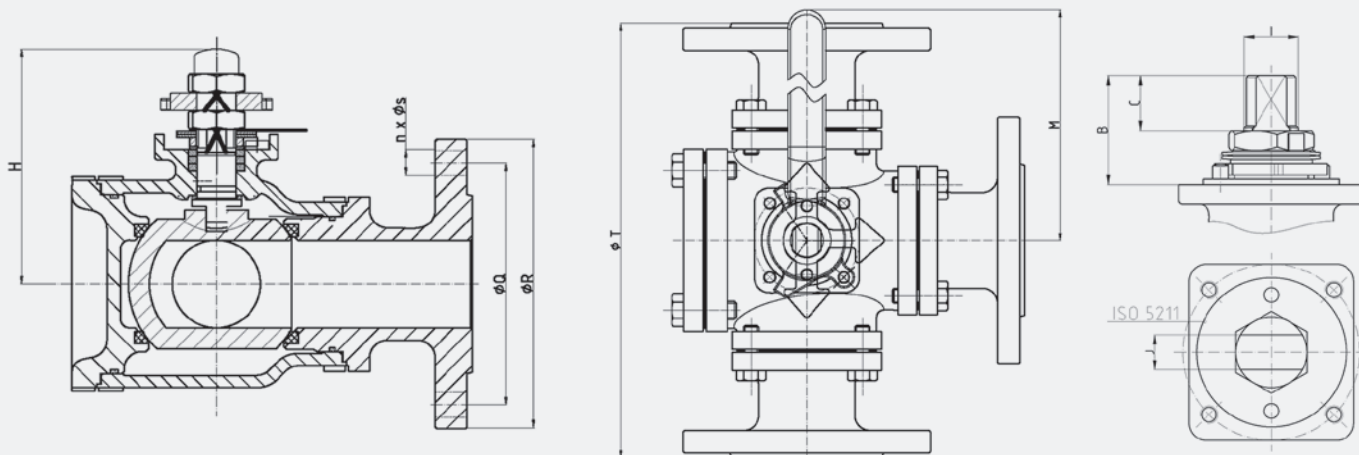

(*) Dimensions of diameters of drills ISO 5211 refer to table from page 60.

Pressure - Temperature

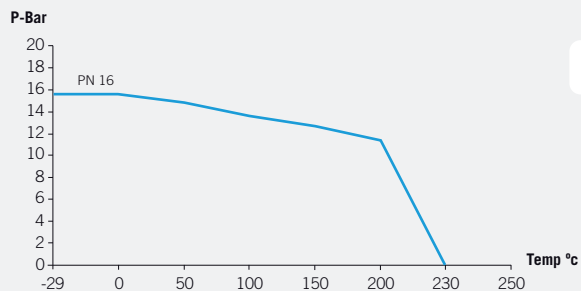

Fig. 916 (PN 16)

DN	øP	øL	A	A1	øR	n x øS	øT	H	M	ISO 5211	B	C	I	J	WEIGHT
25	25	212	106	62	85	4x14	115	96	170	F05	22	12,2	M12x1,5	8	8
40	40	262	131	72	110	4x18	150	121	200	F07	33	19,2	M18x1,5	12	17
50	50	290	145	82	125	4x18	165	134	350	F07	34	20,2	M22x1,5	15	25
65	65	325	162,5	97	145	4x18	185	180	350	F10	34	19,2	M22x1,5	15	34
80	80	370	185	107	160	8x18	200	200	465	F10	45	27,7	M28x1,5	19	51
100	100	430	215	138	180	8x18	220	240	475	F12	56	32,2	M36x1,5	24	77
150	150	500	250	189	240	8x22	285	280	855	F14	69	41	M48x3	32	138
200	200	600	300	270	295	12x22	340	322	855	F14	69	34	M48x3	32	214

TORQUE

VALVE SIZE	AT MAXIMUM DIFFERENTIAL PRESSURE	
	L	T
25 (1")	22	20
40 (1 1/2")	59	57
50 (2")	70	65
65 (2 1/2")	120	110
80 (3")	146	136
100 (4")	350	279
150 (6")	680	660
200 (8")	1.123	1.080

Kv

VALVE SIZE	PORT L	PORT T	
		PORT 2	PORT 3
25 (1")	24	22	54
40 (1 1/2")	58	59	154
50 (2")	78	80	264
65 (2 1/2")	140	142	496
80 (3")	282	316	746
100 (4")	376	378	1.335
150 (6")	736	797	2.583
200 (8")	1.241	953	4.408

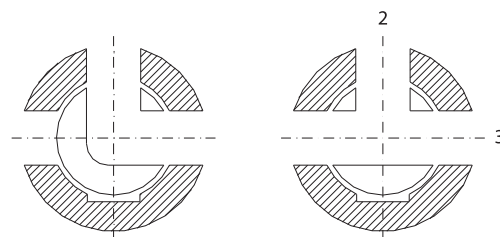

Dimensions in mm, weight in kg and Torque in Nm.
Weights and dimensions can be changed without notice.
Kv Values in m³/h.

| BALL VALVES |

SPECIAL CONSTRUCTIONS

JC Ball Valves can be delivered in special constructions as following:

STEAM JACKET

When viscous materials are handled, JC steam jacketed ball valves are recommended to prevent valve to be blocked in closed position.

The maximum steam jacket pressure is 10 Bar (1.0 Mpa) and maximum temperature is 260°.



CAVITY FILLER

Some of the roughest process controls problems involve fluids than can polymerize in place. That means they can polymerize inside body cavities and could block the valve. Cavity-filler seats are available in PTFE, Stansit, TFM.

Applications: Styrene, Butadiene, Monomers, Pharmaceuticals, Food process, ...

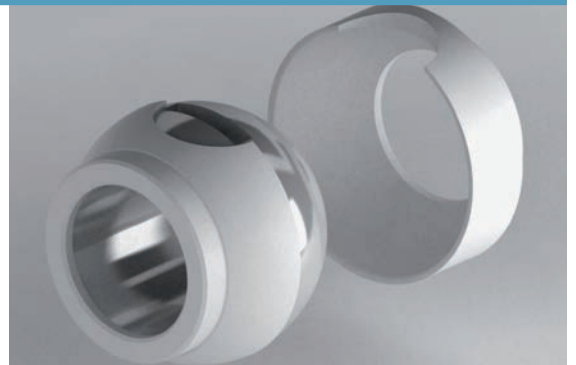

DOUBLE PACKING

Today's concern for the containment of fugitive emissions has brought forth in the industry a wide range of stem sealing concepts and designs aimed to eliminating stem leakage. For these applications where it is imperative that fluid containment has to be assured, double packing can be adapted to any JC ball valve.



CRYOGENIC SERVICE

JC ball valves have been widely used in low temperature and cryogenic applications, including some gas treatment processes (LNG, Methane, LPG...), requiring valves able to be operated and to assure helium leakage rates within specified limits at low temperatures. In these cases JC offers valves designed with special seats, bonnets and materials for low temperature or cryogenic service.



FULLY AUTOMATED BALL VALVES

JC Valves can be delivered with pneumatic, electric, hydraulic or gas-over-oil actuators as per customer requirements.

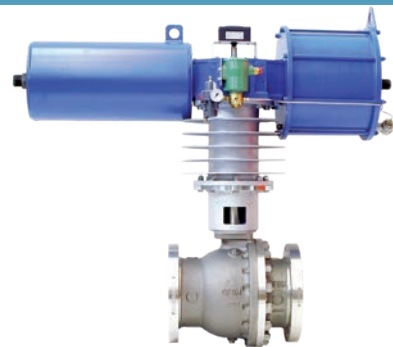

SPECIAL TAILOR MADE VALVES MADE FROM BAR OR FORGINGS

JC tailor made valves are indicated for specific demands, special circumstances, extra-ordinary applications, hard to obtain products and short delivery times. Valves are produced from bar stock materials or forgings with really short time, with exotic materials Nickel alloys (Hastelloy®, Incoloy®, Inconel®, Monel®, Alloy 20, etc.), Titanium, Duplex and Super Duplex and corrosion resistant alloys.



FULLY WELDED VALVES

The JC fully Welded Ball Valve gives it maximum strength at minimum weight as well as maximum resistance both to pipeline pressures and stresses. The compact, spherical design also eliminates body flanges, thus reducing overall size and leak paths.

JC welded body ball valves are used mainly in Gas transmission and distribution pipeline (Mid-stream), typical for underground and buried installation.



P-T CHARTS FOR SEAT MATERIALS

PTFE (Class 600)

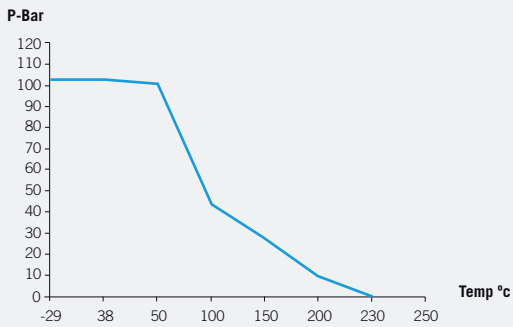

RPTFE (Class 1500)

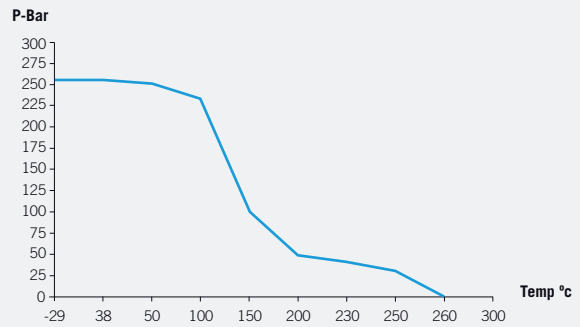

DEVLON V (Class 1500)

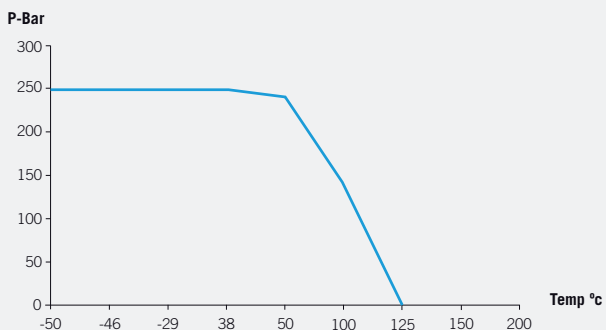

PEEK (Class 2500)

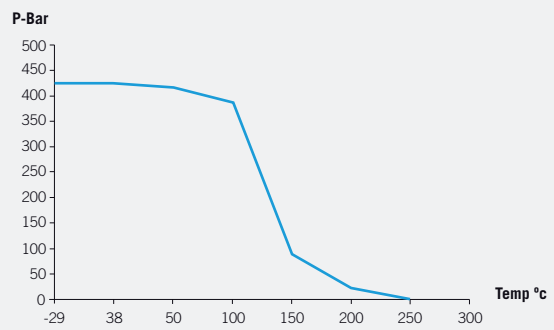

DIMENSIONS OF DRILLS ACCORDING TO ISO 5211

FLANGE TYPE	DIAMETER OF BOLTS CIRCLE	NUMBER SCREWS	DIAMETER OF DRILLS
F03	36	4	M5
F04	42	4	M5
F05	50	4	M6
F07	70	4	M8
F10	102	4	M10
F12	125	4	M12
F14	140	4	M16
F16	165	4	M20
F25	254	8	M16
F30	298	8	M20
F35	356	8	M30
F40	406	8	M36
F48	483	12	M36



MORE PRODUCTS



GATE, GLOBE & CHECK VALVES - TRIPLE OFFSET BUTTERFLY VALVES

ACCESSORIES



PNEUMATIC ACTUATOR - ELECTRIC ACTUATOR - HYDRAULIC ACTUATOR
GAS OVER OIL ACTUATOR - WORM GEAR - LOCKING DEVICES - STEM EXTENSIONS

BALL VALVES

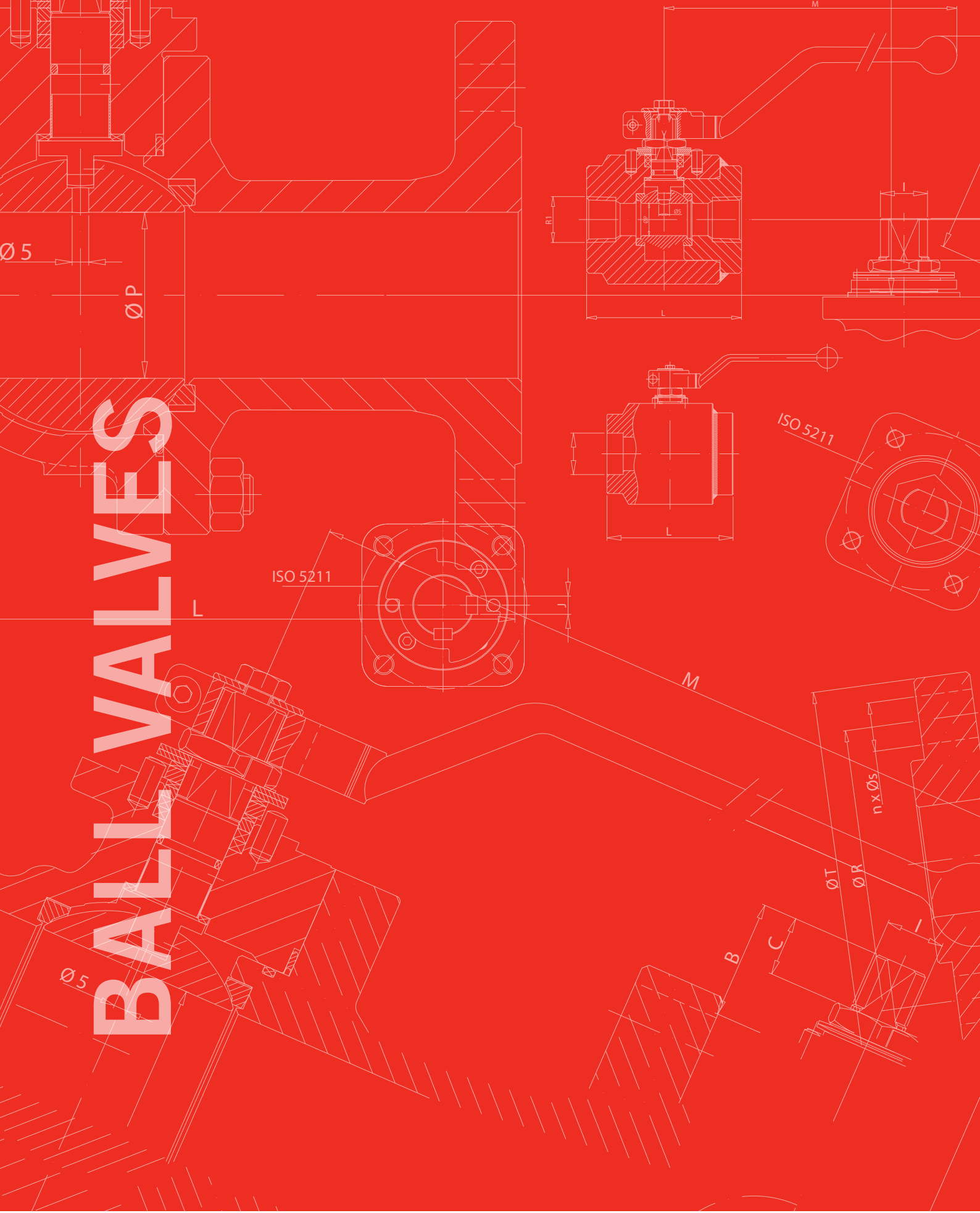

**Valve
& Automation**
Total Valve & Control Solutions®

JOHANNESBURG
Tel: 011 397 2833

DURBAN
Tel: 031 579 2593

South Africa:
0861 103 103

E-mail: sales@valve.co.za
www.valve.co.za



SCAN ME