

Stafsjö®  
SINCE 1666

# Knife gate valve specification guide

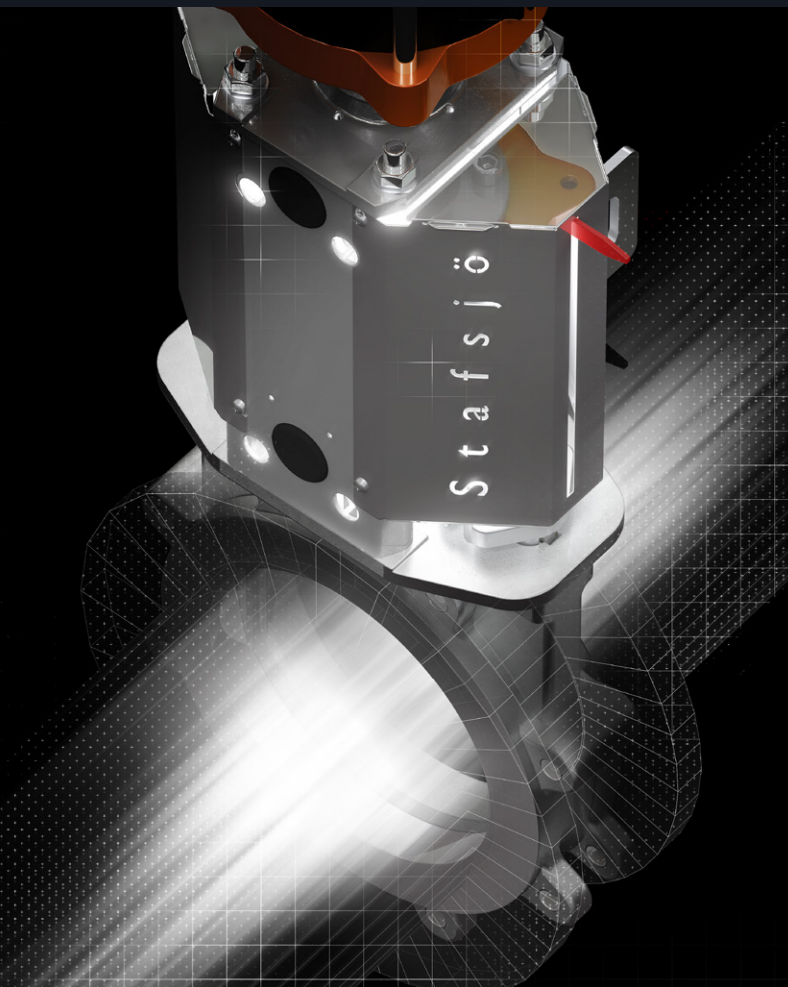

# HX

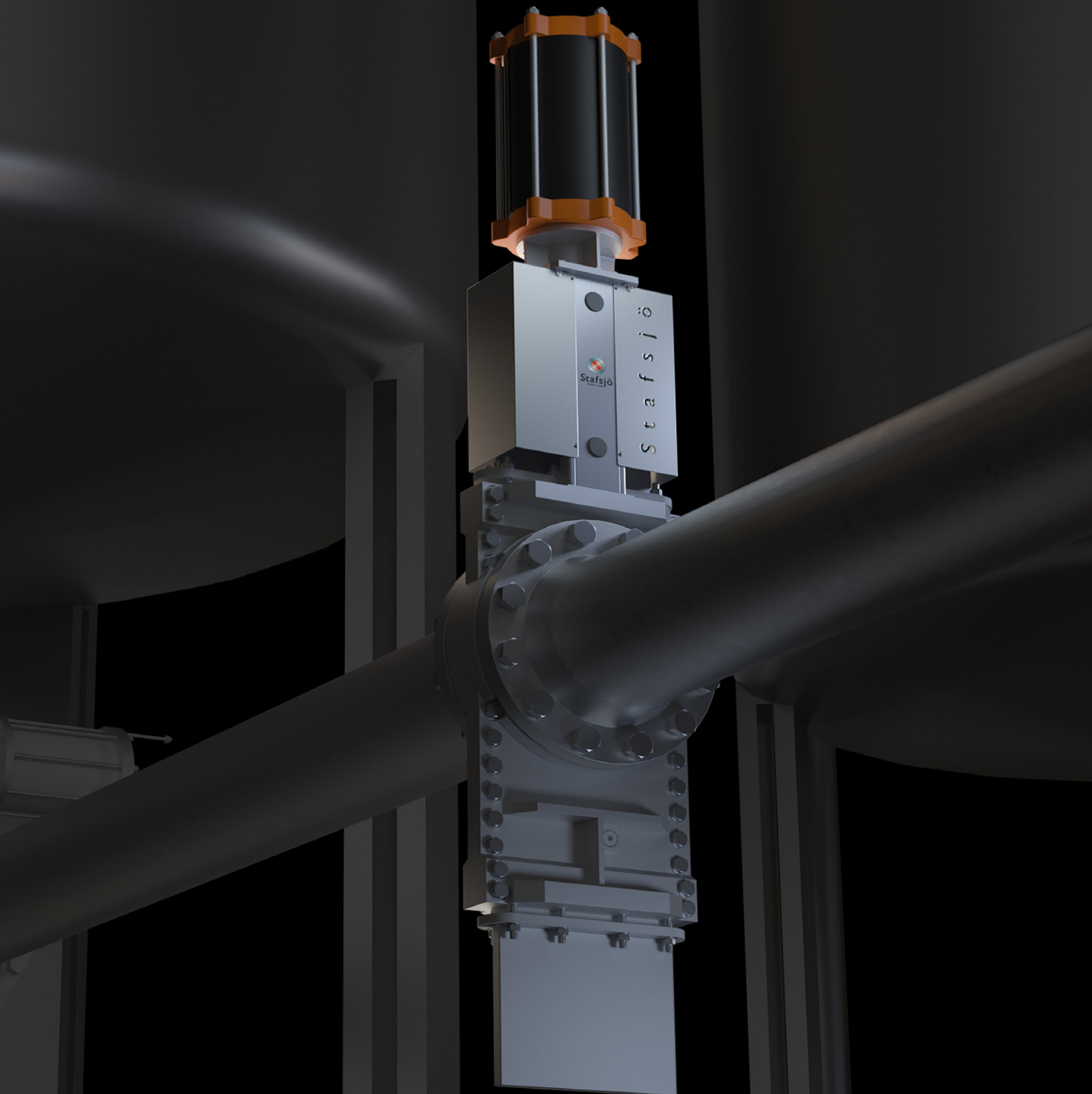

# Index

About Stafsjö	5
Shut-off techniques	8
Products	11
Pressure class	23
Material and actuator service temperatures	25
Describe your knife gate valve	28

# SLF

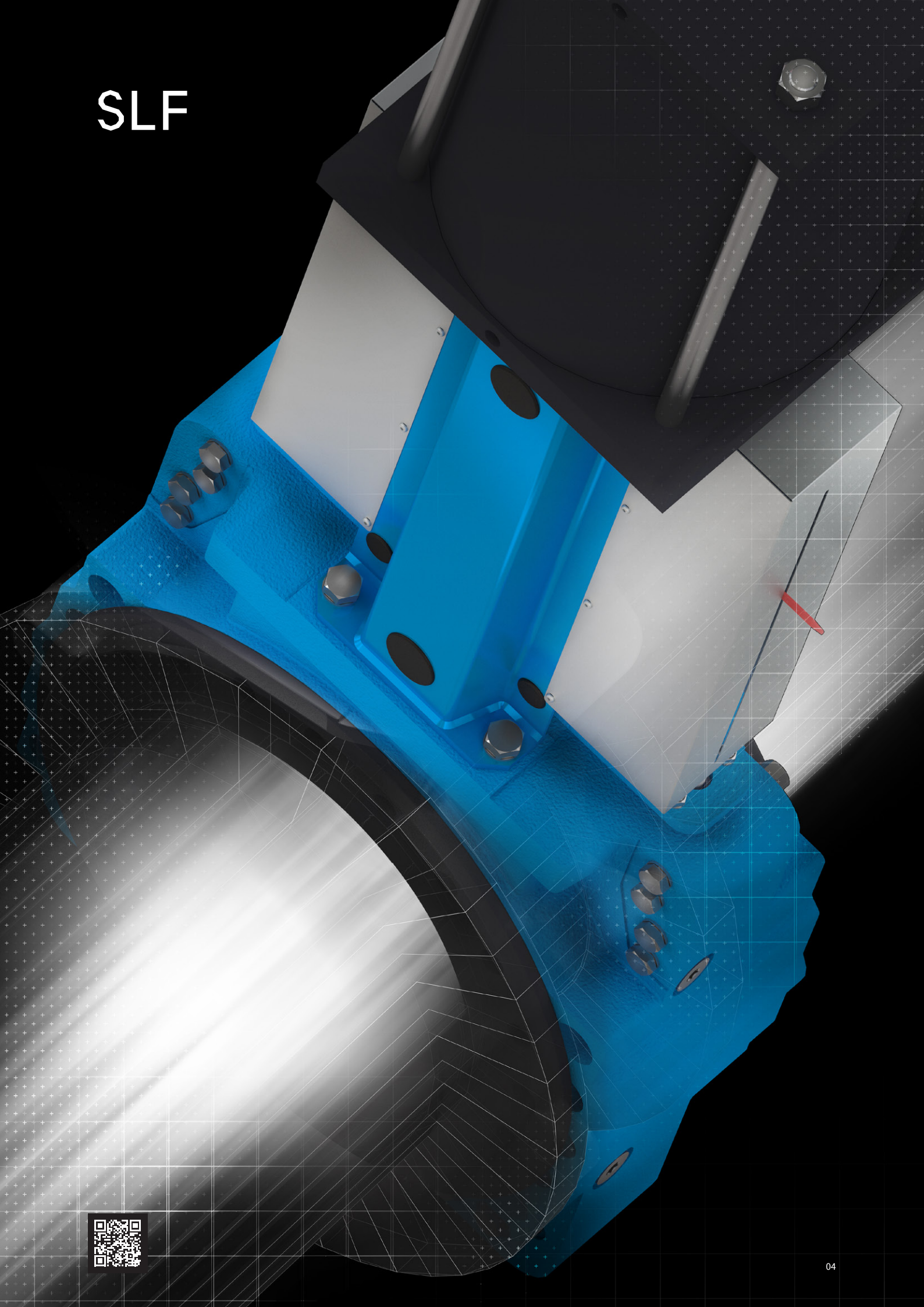

# About Stafsjö

Stafsjö develop and manufacture high performance knife gate valves for reliable and long-lasting operation in demanding industrial processes throughout the world.

Our knife gate valve manufacturing started already in 1928. With strong focus on customer satisfaction and process excellence, the products have evolved throughout the years and new products have been developed to meet and exceed new challenging process conditions. We also offer aftersales support on all continents and automation solutions to meet customer standards across the world.

Stafsjö maintains development and manufacturing on the same location where it all began in 1666, in Stavsjö Sweden. The owner Ebro Armaturen Gebr. Bröer GmbH is headquartered in Hagen, Germany. Together we create world-leading valve and automation solutions.



[stafsjö.com/about-us/](https://stafsjö.com/about-us/)



[ebro-armaturen.com/en/company/about-us/](https://ebro-armaturen.com/en/company/about-us/)

# Who we are

## Expect commitment

We are committed in each and every supply, day by day, year after year. First class product quality can be expected. Our commitment do not end when the products exit our facility. We are just as committed to serve our customers after the products have been in service for years or even decades.

## Long-term partner

Long-term is a significant characteristic for Stafsjö. Our solutions are engineered and made to last. Nothing is left to chance. We also believe in close and open collaborations with customers, among colleagues, business partners and other stakeholders. We work hard to earn the trust.



## Make a difference

We have a strong devotion to meet and exceed our customers' expectations. Our customers depend on our products performance and reliability to enhance their productivity, efficiency and safety targets. The products we supply are developed and manufactured to perform and to provide reliable isolation whenever required.



# Our vision

## “First in knife gate solutions”

Our vision describes our ambition to be the most efficient and productive knife gate supplier, the technology leader and the most preferred brand within selected industrial segments.



# Shut-off techniques for a wide range of applications

## Uni-directional

Knife gate valves: JTV, MV, RKO, RKS and TV

This knife gate valve range have been designed with uni-directional flow in mind even though some of them can deal with certain reverse flow as standard. Installation position and pressure direction are important factors to consider when choosing uni-directional knife gate valves. Independent if it is dry media or liquids, the uni-directional knife gate valves will provide high operation reliability and zero leakage isolation.



## Bi-directional

Knife gate valves: WB, WB11, WB14, WB14E and XV

This is the range to choose if you are searching for allround and compact knife gates valves for liquids. All provide a smooth flow path with minimal flow impact and bi-directional zero leakage shut-off. Some of them are also available as fully lugged for dead-end services.



# Select technique suitable for your process

## Bi-directional, through-going

Knife gate valves: HL, HG, HP, HPT and HX

This range enable high operation reliability on highly concentrated media. The gate is able to cut through static media columns and provide zero leakage isolation independent of pressure direction. Several high alloy material options are available on request.



## Bi-directional, push through

Knife gate valves: SLF, SLH, SLV and SLX

In tough abrasive mineral processing applications, the most durable knife gate valves are the push through slurry valves. These form a rubber lined extension of the pipe line when they are in opened position. When cycling to closed position, the two seats are displaced axially forming a seal with the gate until it forms a complete closure and provide 100% bi-directional zero leakage shut-off.



# Knife gate valves for a wide range of industrial applications

The knife gate solutions we manufacture provide reliable isolation in pulp and paper mills, in mineral concentrator plants and their tailing systems, in waste water treatment plants and in many more industrial systems. We have the solutions for both dry media and liquids, for slightly abrasive to extreme, from moderate corrosive conditions to the very extreme calling for high grade materials such as Titanium. We offer knife gate solutions up to 50 bar pressure class.

Contact our valve experts!

We are never far away. Smooth logistic solutions, local stocks combined with local sales support in many countries ensure you availability and high service level independent where your business operate.



# D2G



This product have two hard chromed gates working towards each other in the bore, providing extremely fast shut-off performance. It is suitable for stock preparation and wood chip cleaners or as junk trap valve in recycled fibre lines.

Size range	DN 150 - DN 600 (6" - 24")
Shut-off technique	Bi-directional
Connection type	Wafer/Semi lugged
Face-to-face	Stafsjö manufacturing standard
Design standard	PED 2014/68/EU category I and II module A2
Test standard	EN 12266-1:2003 rate A**
ATEX availability	On request
Valve body	Stainless steel EN 1.4408
Valve gate and surface treatments	Hard chromed stainless steel EN 1.4404 Hard chromed duplex stainless steel EN 1.4462*
Valve seat	PTFE
Valve packing	TwinPack WhitePack*

\* Non-standard materials available as options

\*\*The D2G is subject for pressure test in opened position only with water at 20 °C according to EN 12266-1:2003 rate A.

# HG



This is a through-going high performance knife gate valve with superior flow characteristics, offering reliable bi-directional zero leakage shut-off on highly concentrated media and static media columns.

Size range	DN 50 - DN 1200 (2" - 48")
Shut-off technique	Bi-directional, through-going
Connection type	Wafer/Semi lugged
Face-to-face	Stafsjö manufacturing standard Option in MSS-SP81
Design standard	PED 2014/68/EU category I and II module A2
Test standard	EN 12266-1:2003 rate A**
ATEX availability	On request
Valve body	Duplex stainless steel EN 1.4470* Nodular iron EN 5.3105 Stainless steel EN 1.4408 254 SMO equivalent*
Valve gate and surface treatments	Stainless steel EN 1.4404 Duplex stainless steel EN 1.4462* 254 SMO or equivalent* Hard chrome or extra polished surface*
Valve seat	Polyurethane PTFE or FDA/EC 1935/2004 approved PTFE Stainless steel
Valve packing	TwinPack WhitePack* FDA/EC 1935/2004 PTFE* Graphite*

\* Non-standard materials available as options

\*\* Rate A is not applicable on metal seated valves.

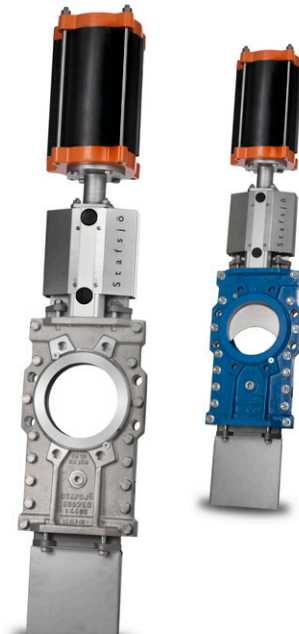
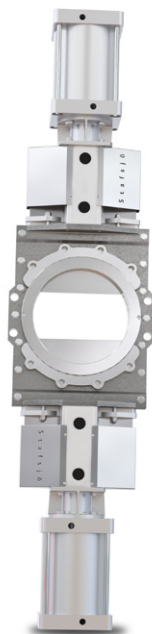

# HL



This is a compact through-going knife gate valve with superior flow characteristics, offering reliable bi-directional zero leakage shut-off on highly concentrated media and static media columns.

Size range	DN 400 - DN 800 (16" - 32")
Shut-off technique	Bi-directional, through-going
Connection type	Wafer/Semi lugged
Face-to-face	Stafsjö manufacturing standard
Design standard	PED 2014/68/EU category I and II module A2
Test standard	EN 12266-1:2003 rate A
ATEX availability	On request
Valve body	Stainless steel EN 1.4408
Valve gate and Surface treatments	Stainless steel EN 1.4404
	Duplex stainless steel EN 1.4462* Hard chrome or extra polished surface*
Valve seat	PTFE
Valve packing	TwinPack
	WhitePack*

\* Non-standard materials available as options

# HP



This is a high pressure version of the well-known through-going HG knife gate valve, available in 10 bar pressure class all the way up to DN 800 (32") and 6 bar on DN 900 - DN 1000 (36" - 40").

Size range	DN 300 - DN 1000 (12" - 40")
Shut-off technique	Bi-directional, through-going
Connection type	Wafer/Semi lugged
Face-to-face	Stafsjö manufacturing standard Option in MSS-SP81
Design standard	PED 2014/68/EU category I and II module A2
Test standard	EN 12266-1:2003 rate A
ATEX availability	On request
Valve body	Duplex stainless steel EN 1.4470*
	Stainless steel EN 1.4408 254 SMO equivalent*
Valve gate and surface treatments	Duplex stainless steel EN 1.4462 254 SMO or equivalent*
	Hard chrome or extra polished surface*
Valve seat	PTFE
Valve packing	TwinPack
	WhitePack*

\* Non-standard materials available as options



# HPT



The HPT is a through-going knife gate valve with superior flow characteristics, offering reliable bi-directional zero leakage shut-off up to 10 bar. All wetted parts are made of Titanium and PTFE making it suitable for the most corrosive chemicals.

Size range	DN 100 - DN 700 (4" - 28")
Shut-off technique	Bi-directional, through-going
Connection type	Wafer/Semi lugged
Face-to-face	Stafsjö manufacturing standard
Design standard	PED 2014/68/EU category I and II module A2
Test standard	EN 12266-1:2003 rate A
Valve body	Titanium ASTM B265 Grade 2
Valve gate	Titanium ASTM B265 Grade 2
Valve seat	PTFE
Valve packing	TwinPack
	WhitePack*

\* Non-standard materials available as options

# HX



The HX is an extreme through-going high pressure knife gate valve for really demanding applications. It features excellent flow characteristics and provide a tight seal independent of pressure direction.

Size range	DN 150 - DN 900 (6" - 36")
Shut-off technique	Bi-directional, through-going
Connection type	Wafer/Semi lugged
Face-to-face	Stafsjö manufacturing standard
Design standard	PED 2014/68/EU category I and II module A2
Test standard	EN 12266-1:2003 rate A
ATEX availability	On request
Valve body	Duplex stainless steel EN 1.4470*
	Stainless steel EN 1.4408
	254 SMO equivalent*
Valve gate and surface treatments	Titanium ASTM B265 Grade 2*
	Stainless steel EN 1.4404
	Duplex stainless steel EN 1.4462
Valve seat	Titanium ASTM B265 Grade 2*
	254 SMO or equivalent*
	Hard chrome or extra polished surface*
Valve packing	PTFE
Valve packing	TwinPack with PTFE scrapers
	WhitePack with PTFE scrapers*

\* Non-standard materials available as options



# Quick and easy maintenance

Long-term is a well-known characteristic for Stafsjö and our products. We want the products to perform through decades. With Stafsjö's retainer ring system you can repeatedly extend the service life, while minimizing downtime and cost. Any maintenance can be carried out quick and easy. The retainer ring system is available on D2G, HG, HL, HP, HPT, HX, JTV, MV, RKO and XV.

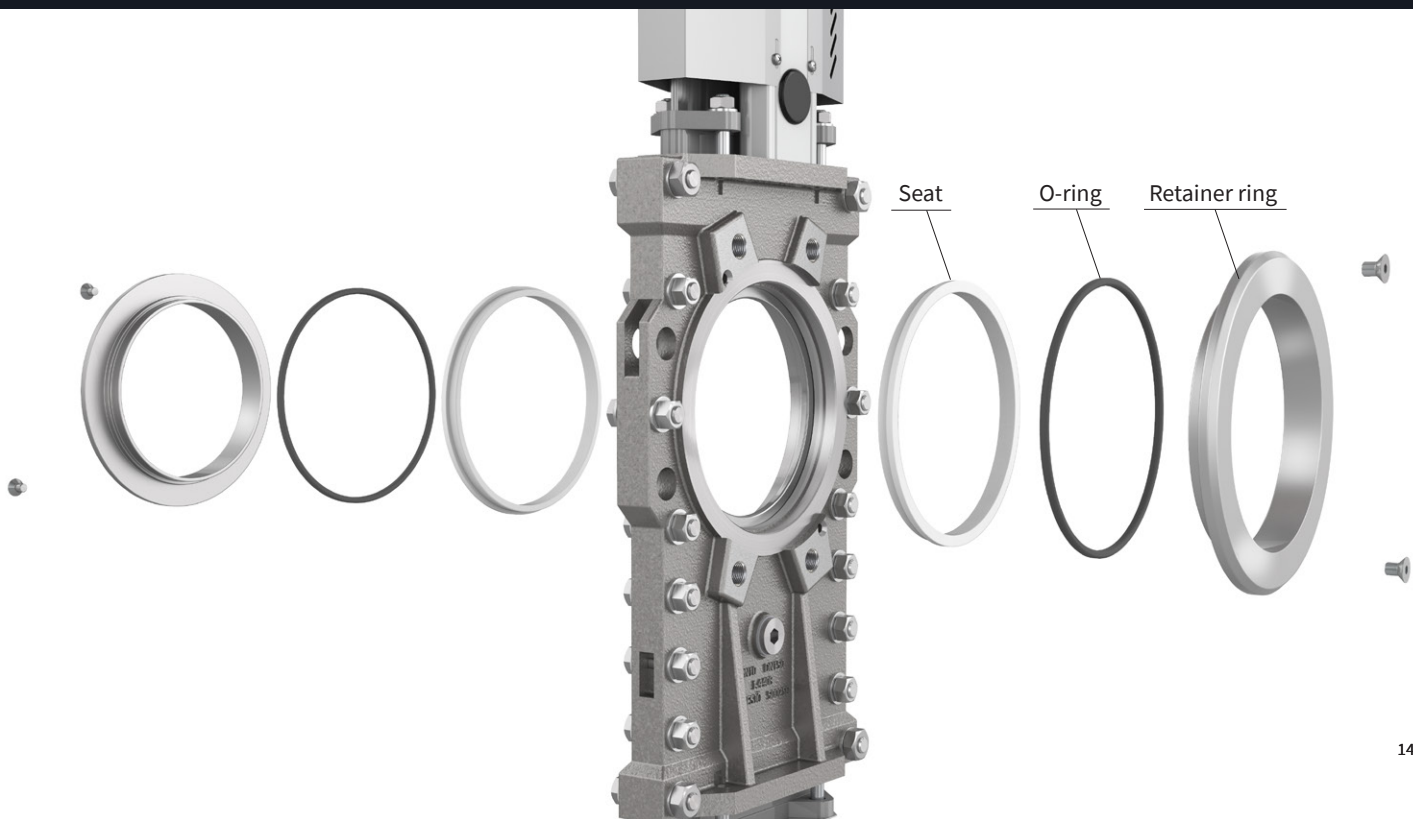

# JT



This is a complete Junk Trap for abrasive reject separation, primarily for HD cleaners in recycled fibre lines. The JT is specially developed to minimize turbulence, erosive wear and build-up of solids and reject materials.

Size range	RKO: DN 100 - DN 200 (4" - 8") JTV: 250 x 250 (10" x 10")
Shut-off technique	Uni-directional
Connection type	Fully lugged
Face-to-face	Stafsjö manufacturing standard
Design standard	PED 2014/68/EU category I and II module A2
Test standard	EN 12266-1:2003 rate A The reject tank is pressure tested with water 1,5 times max working pressure**
Tank, splash guard	Stainless steel EN 1.4404**
Valve body	Stainless steel EN 1.4408
Valve gate and surface treatments	Hard chromed duplex stainless steel EN 1.4462
Valve seat	Polyurethane
Valve packing	TwinPack WhitePack*

\* Non-standard materials available as options

\*\* Applicable for tank only

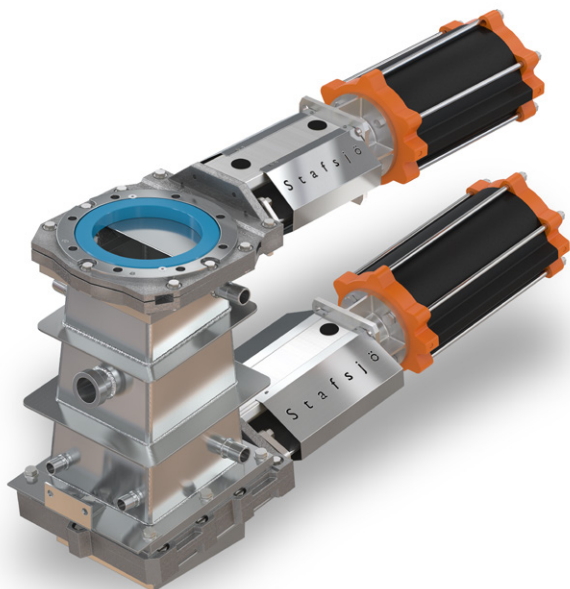

# JTV



The JTV is a square knife gate valve for junc traps and high density cleaners separating abrasive materials such as sand, stones, staples, glass and other type of reject from the process media.

Size range	250 x 250 (10" x 10")
Shut-off technique	Uni-directional
Connection type	Fully lugged (Suitable for dead-end service)
Face-to-face	Stafsjö manufacturing standard
Design standard	PED 2014/68/EU category I and II module A2
Test standard	EN 12266-1:2003 rate A
ATEX availability	On request
Valve body	Stainless steel EN 1.4408
Valve gate and surface treatments	Hard chromed duplex stainless steel EN 1.4462
Valve seat	Polyurethane
Valve packing	TwinPack WhitePack*

\* Non-standard materials available as options



# MV



This is a uni-directional valve for on-off or control, suitable for both liquids and dry media. Extremely reliable shut-off performance have made it popular amongst users worldwide. The modular design and simple maintenance makes it easy to achieve low cost of ownership.

Size range	DN 50 - DN 1800 (2" - 72")
Shut-off technique	Uni-directional
Connection type	Wafer/Semi lugged
Face-to-face	Stafsjö manufacturing standard Option in MSS-SP81
Design standard	PED 2014/68/EU category I and II module A2
Test standard	EN 12266-1:2003 rate A**
ATEX availability	On request
Valve body	Duplex stainless steel EN 1.4470*
	Nodular iron EN 5.3105, EN-JS1050, GGG50
	Stainless steel EN 1.4408
	254 SMO equivalent*
Valve gate and surface treatments	Stainless steel EN 1.4301 or EN 1.4404
	Duplex stainless steel EN 1.4462*
	254 SMO or equivalent*
Valve seat	Hard chrome or extra polished surface*
	EPDM, FKM/FPM, NBR or Polyurethane
	PTFE or FDA/EC 1935/2004 approved PTFE
Valve packing	Stainless steel
	TwinPack
	WhitePack*
	FDA/EC 1935/2004 approved PTFE*
	Graphite*

\* Non-standard materials available as options

\*\* Rate A is not applicable on metal seated valves.

# RKO



This is a robust valve for high density cleaners with large amount of abrasive and difficult solids. A straight bevel gate edge cut through and provide a tight seal against the seat. The larger square outlet enable full release of difficult media at drain sequence.

Size range	DN 100 - DN 600 (4" - 24")
Shut-off technique	Uni-directional
Connection type	Fully lugged (Suitable for dead-end service)
Face-to-face	Stafsjö manufacturing standard
Design standard	PED 2014/68/EU category I and II module A2
Test standard	EN 12266-1:2003 rate A
ATEX availability	On request
Valve body	Stainless steel EN 1.4408
	Nodular iron EN 5.3105
Valve gate and surface treatments	Hard chromed duplex stainless steel EN 1.4462
Valve seat	Polyurethane
	PTFE
Valve packing	TwinPack
	WhitePack*

\* Non-standard materials available as options



# RKS



This is a uni-directional square or rectangular stainless steel knife gate valve, often used in applications with media such as bulk and sludge.

Size range	200 x 200 - 1000 x 1000 (8" x 8" - 40" x 40")
Shut-off technique	Uni-directional
Connection type	Wafer/Semi lugged
Face-to-face	Stafsjö manufacturing standard
Design standard	TKN 1987 and RN 1978
Test standard	Pressure tests are not performed on the body. Seat tightness test is only performed with NBR seat.
Valve body	Stainless steel EN 1.4404
Valve gate	Stainless steel EN 1.4301 Stainless steel EN 1.4404*
Valve seat	Brass NBR
Valve packing	TwinPack WhitePack*

\* Non-standard materials available as options

# SLF



This is a heavy duty push through slurry knife gate valve with superior flow characteristics, offering reliable and bi-directional shut-off performance in the most abrasive and demanding mineral processing applications.

Size range	DN 80 - DN 800 (3" - 32")
Shut-off technique	Bi-directional, push through
Connection type	Flanged up to DN 400 (16") Fully lugged DN 450 - DN 800 (18" - 32")
Face-to-face	Stafsjö manufacturing standard
Design standard	PED 2014/68/EU category I and II module A2
Test standard	EN 12266-1:2003 rate A
Valve body	Nodular iron EN 5.3105
Valve gate	Duplex stainless steel EN 1.4462
Valve seat	EPDM Natural rubber
Valve packing	TwinPack with UHMW-PE scraper

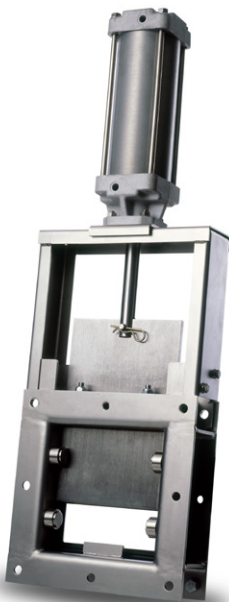

# SLH



This heavy duty push through slurry knife gate valve is designed to operate and provide bi-directional tight seal up to 20 bar in demanding mineral processing applications, typically slurry tailing systems.

Size range	DN 80 - DN 650 (3" - 26")
Shut-off technique	Bi-directional, push through
Connection type	Fully lugged
Face-to-face	Stafsjö manufacturing standard
Design standard	PED 2014/68/EU category I and II module A2
Test standard	EN 12266-1:2003 rate A
Valve body	Nodular iron EN 5.3105
Valve gate and surface treatments	Hard anti-stick coated high strength stainless steel
Valve seat	EPDM Natural rubber
Valve packing	TwinPack with UHMW-PE scraper

# SLV



This is a compact push through slurry knife gate valve with superior flow characteristics, offering reliable and bi-directional shut-off performance in abrasive and demanding mineral processing applications.

Size range	DN 50 - DN 900 (2" - 36")
Shut-off technique	Bi-directional, push through
Connection type	Wafer/Semi lugged
Face-to-face	Stafsjö manufacturing standard
Design standard	PED 2014/68/EU category I and II module A2
Test standard	EN 12266-1:2003 rate A
Valve body	Nodular iron EN 5.3105
Valve gate	Duplex stainless steel EN 1.4462
Valve seat	EPDM Natural rubber
Valve packing	TwinPack with UHMW-PE scraper



# SLX



This is an extreme push through slurry knife gate valve, designed to operate and provide bi-directional tight seal up to 50 bar in demanding mineral processing applications, typically slurry tailing systems.

Size range	DN 80 - DN 450 (3" - 18")
Shut-off technique	Bi-directional, push through
Connection type	Fully lugged
Face-to-face	Stafsjö manufacturing standard
Design standard	PED 2014/68/EU category I and II module A2
Test standard	EN 12266-1:2003 rate A
Valve body	Nodular iron EN 5.3105
Valve gate and surface treatments	Hard anti-stick coated high strength stainless steel
Valve seat	EPDM
	Natural rubber
Valve packing	TwinPack with UHMW-PE scraper

# TV



This is a transmitter isolation valve that can be used on both dry media and liquids. The compact design and unique flange pattern enable direct installation on the tank wall and downstream transmitter or any other equipment can be disengaged without draining the tank.

Size range	DN 80 (3")
Shut-off technique	Uni-directional
Connection type	Fully lugged (Suitable for dead-end service)
Face-to-face	Stafsjö manufacturing standard Option in MSS-SP81
Design standard	PED 2014/68/EU category I and II module A2
Test standard	EN 12266-1:2003 rate A
ATEX availability	On request
Valve body	Stainless steel EN 1.4408
Valve gate	Stainless steel EN 1.4404
	Duplex stainless steel EN 1.4462*
Valve seat	EPDM
	FPM/FKM
	NBR
	PTFE
Valve packing	FDA/EC 1935/2004 approved PTFE
	TwinPack
	WhitePack*
	FDA/EC 1935/2004 approved PTFE*
	Graphite*

\* Non-standard materials available as options



# WB



This compact knife gate valve is suitable for fluids such as water, sludge and biomass. It offers superior flow characteristics and bi-directional zero leakage shut-off.

Size range	DN 350 - DN 1600 (14" - 64")
Shut-off technique	Bi-directional
Connection type	Wafer/Semi lugged
Face-to-face	Stafsjö manufacturing standard
Design standard	PED 2014/68/EU category I and II module A2
Test standard	EN 12266-1:2003 rate A
ATEX availability	On request
Valve body	Nodular iron EN 5.3105
	Duplex stainless steel EN 1.4462*
Valve gate	Stainless steel EN 1.4301
	Stainless steel EN 1.4404*
Valve seat	EPDM
	NBR
Valve packing	TwinPack

\* Non-standard materials available as options

# WB11



This is a bi-directional semi lugged/wafer type knife gate valve with excellent flow characteristics suitable for fluids. Integrated NBR flange gaskets on all sizes simplify installation works.

Size range	DN 50 - DN 300 (2" - 12")
Shut-off technique	Bi-directional
Connection type	Wafer/Semi lugged
Face-to-face	EN 558-1 series 20 and ISO 5752 series 20
Design standard	PED 2014/68/EU category I and II module A2
Test standard	EN 12266-1:2003 rate A
ATEX availability	On request
Valve body	Nodular iron EN-JS1050, GGG50
	Duplex stainless steel EN 1.4462*
Valve gate	Stainless steel EN 1.4301
	Stainless steel EN 1.4404*
Valve seat	EPDM
	FEPM
	NBR
Valve packing	TwinPack

\* Non-standard materials available as options



# WB14



This is a bi-directional fully lugged knife gate valve with excellent flow characteristics suitable for fluids. Integrated NBR flange gaskets on all sizes simplify installation works.

Size range	DN 50 - DN 600 (2" - 24")
Shut-off technique	Bi-directional
Connection type	Fully lugged (Suitable for dead-end service)
Face-to-face	EN558-1 series 20 and ISO 5752 series 20 MSS-SP81
Design standard	PED 2014/68/EU category I and II module A2
Test standard	EN 12266-1:2003 rate A
ATEX availability	On request
Valve body	Nodular iron EN 5.3105, EN-JS1050, GGG50 Duplex stainless steel EN 1.4462*
Valve gate	Stainless steel EN 1.4301 Stainless steel EN 1.4404*
Valve seat	EPDM FEPM NBR
Valve packing	TwinPack

\* Non-standard materials available as options

# WB14E



This is a fully lugged high performance knife gate valve with superior flow characteristics, offering bi-directional zero leakage shut-off. It is suitable for fluids such as pulp stock, chemicals, sludge, biomass and water.

Size range	DN 50 - DN 900 (2" - 36")
Shut-off technique	Bi-directional
Connection type	Fully lugged (Suitable for dead-end service)
Face-to-face	MSS-SP81
Design standard	PED 2014/68/EU category I and II module A2
Test standard	EN 12266-1:2003 rate A
ATEX availability	On request
Valve body	Duplex stainless steel EN 1.4470 ≥ DN 350 (14")* Stainless steel EN 1.4408 254 SMO equivalent ≥ DN 350 (14")*
Valve gate	Duplex stainless steel EN 1.4462* Stainless steel EN 1.4404 254 SMO or equivalent*
Valve seat	EPDM FEPM NBR
Valve packing	TwinPack with PTFE scraper

\* Non-standard materials available as options



# XV



This is a compact chemical resistant and bi-directional knife gate valve suitable for fluids such as pulp stock, biomass and sludge. The XV is supplied with either a fully or a semi lugged valve body.

Size range	DN 65 - DN 1000 (2.5" - 40")
Shut-off technique	Bi-directional
Connection type	Wafer/Semi lugged
	Fully lugged
	Fully lugged suitable for dead-end service DN 80 - DN 200 (3" - 8")
Face-to-face	Stafsjö manufacturing standard Option in MSS-SP81
Design standard	PED 2014/68/EU category I and II module A2
Test standard	EN 12266-1:2003 rate A
ATEX availability	On request
Valve body	Stainless steel EN 1.4408
Valve gate	Stainless steel EN 1.4404
	Duplex stainless steel EN 1.4462*
Valve seat	PTFE
	FDA/EC 1935/2004 approved PTFE
Valve packing	TwinPack
	WhitePack* FDA/EC 1935/2004 approved PTFE*

\* Non-standard materials available as options

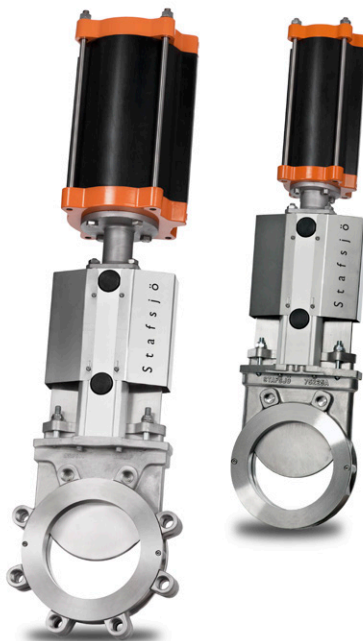

# Pressure class (bar)

Below table provide "Max working pressure" / "Max differential pressure" at 20 °C except for HX which is specified at 110 °C.

Stafsjö's valves are subject for pressure tests before delivery in opened and closed position with water at 20 °C according to EN 12266-1:2003 rate A. No visually detectable leakage is allowed for duration of the test. Rate A is not applicable on metal seated valves. On request Stafsjö can provide 2.2 test report and 3.1 inspection certificate according to EN 10204.

DN	D2G	HG	HL	HP	HPT	HX	JT	JTV <sup>1)</sup>	MV	RKO
50		10 / 10							16 / 16	
65									16 / 16	
80		10 / 10							16 / 16	
100	10 / 6	10 / 10			10 / 10		6 / 6		16 / 16	10 / 6,2
125	10 / 6	10 / 10			10 / 10		6 / 6		16 / 16	10 / 6,2
150	10 / 6	10 / 10			10 / 10	20 / 20	6 / 6		10 / 10	10 / 6,2
200	10 / 6	10 / 10			10 / 10	20 / 20	6 / 6		10 / 10	10 / 6,2
250	10 / 6	10 / 10			10 / 10	20 / 20	6 / 6	6 / 6	10 / 10	10 / 6,2
300	10 / 6	6 / 6		10 / 10	10 / 10	20 / 20			10 / 10	10 / 6,2
350	10 / 6	6 / 6		10 / 10	10 / 10	20 / 20			6 / 6	10 / 6,2
400	10 / 6	6 / 6	6 / 6	10 / 10	10 / 10	20 / 20			6 / 6	10 / 6,2
450		6 / 6		10 / 10	10 / 10	20 / 20			6 / 6	10 / 6,2
500	6 / 4	6 / 6	4 / 4	10 / 10	10 / 10	20 / 20			6 / 6	6 / 4
600	6 / 4	6 / 6	4 / 4	10 / 10	10 / 10	20 / 20			6 / 6	6 / 4
700		6 / 6	4 / 4	10 / 10	10 / 10	20 / 20			4 / 4	
750		6 / 6		10 / 10					4 / 4	
800		6 / 6	4 / 4	10 / 10		20 / 20			4 / 4 <sup>2)</sup>	
900		4 / 4		6 / 6		16 / 16			4 / 4	
1000		4 / 4		6 / 6					4 / 4	
1200		4 / 4							4 / 2 or 4	
1400									4 / 2 or 4	
1600									4 / 2 or 4	
1800									4 / 2 or 4	

1) The JTV has a square 250 x 250 mm bore.

2) MV DN 800 is also available in a 10 / 10 bar version. Offer on request.

DN	SLV	SLF	SLH	SLX	TV	WB	WB11	WB14	WB14E	XV
50	10 / 10						10 / 10	10 / 10	10 / 10	
65	10 / 10						10 / 10	10 / 10		16 / 10
80	10 / 10	10 / 10	20 / 20	50 / 50	16 / 3,5		10 / 10	10 / 10	10 / 10	16 / 10 <sup>3)</sup>
100	10 / 10	10 / 10	20 / 20	50 / 50			10 / 10	10 / 10	10 / 10	16 / 10 <sup>3)</sup>
125	10 / 10						10 / 10	10 / 10		16 / 10 <sup>3)</sup>
150	10 / 10	10 / 10	20 / 20	50 / 50			10 / 10	10 / 10	10 / 10	16 / 10 <sup>3)</sup>
200	10 / 10	10 / 10	20 / 20	50 / 50			10 / 10	10 / 10	10 / 10	10 / 10 <sup>3)</sup>
250	10 / 10	10 / 10	20 / 20	50 / 50			10 / 10	10 / 10	10 / 10	10 / 10
300	10 / 10	10 / 10	20 / 20	50 / 50			10 / 10	10 / 10	10 / 10	10 / 10
350	10 / 10	10 / 10	20 / 20	50 / 50		6 / 6		10 / 6 or 10	10 / 6 or 10	10 / 10
400	10 / 10	10 / 10	20 / 20	50 / 50		6 / 6		10 / 6 or 10	10 / 6 or 10	10 / 6
450	10 / 6	10 / 6	20 / 20	50 / 50				10 / 6 or 10	10 / 6 or 10	10 / 6
500	10 / 6	10 / 6	20 / 20			4 / 4		10 / 4 or 10	10 / 4 or 10	10 / 6
600	10 / 6	10 / 6	20 / 20			4 / 4		10 / 4 or 10	10 / 4 or 10	10 / 6
650			20 / 20							
700	5 / 5					4 / 2 or 4				6 / 4
750		5 / 5							4 / 4 or 6 / 6	
800	5 / 5	5 / 5				4 / 2 or 4			4 / 4 or 6 / 6	6 / 4
900	5 / 5					4 / 2 or 4				6 / 4
1000						4 / 1 or 2				4 / 4
1200						4 / 1 or 2				
1400						2 / 1				
1600						2 / 1				

3) The XV is also available in a 12,5 bar version in DN 80 - DN 200 (3" - 8").

# A first-rate seal to atmosphere

Stafsjö's TwinPack offers high mechanical strength, excellent chemical resistance and a tight seal to atmosphere. The TwinPack braid is made up by an elastic silicon rubber core surrounded by diagonally interlocked graphite filled PTFE with aramid fiber reinforced corners. The TwinPack braids resist pH 2-13 and temperatures -60 °C up to 260 °C. The stuffing box can also be reinforced with scrapers to further support the seal and some knife gate valves are also available with double gland for the most demanding applications.

Our valve experts at Stafsjö and all around the world are ready to support if you have any questions on knife gate valve configurations suitable for your process.

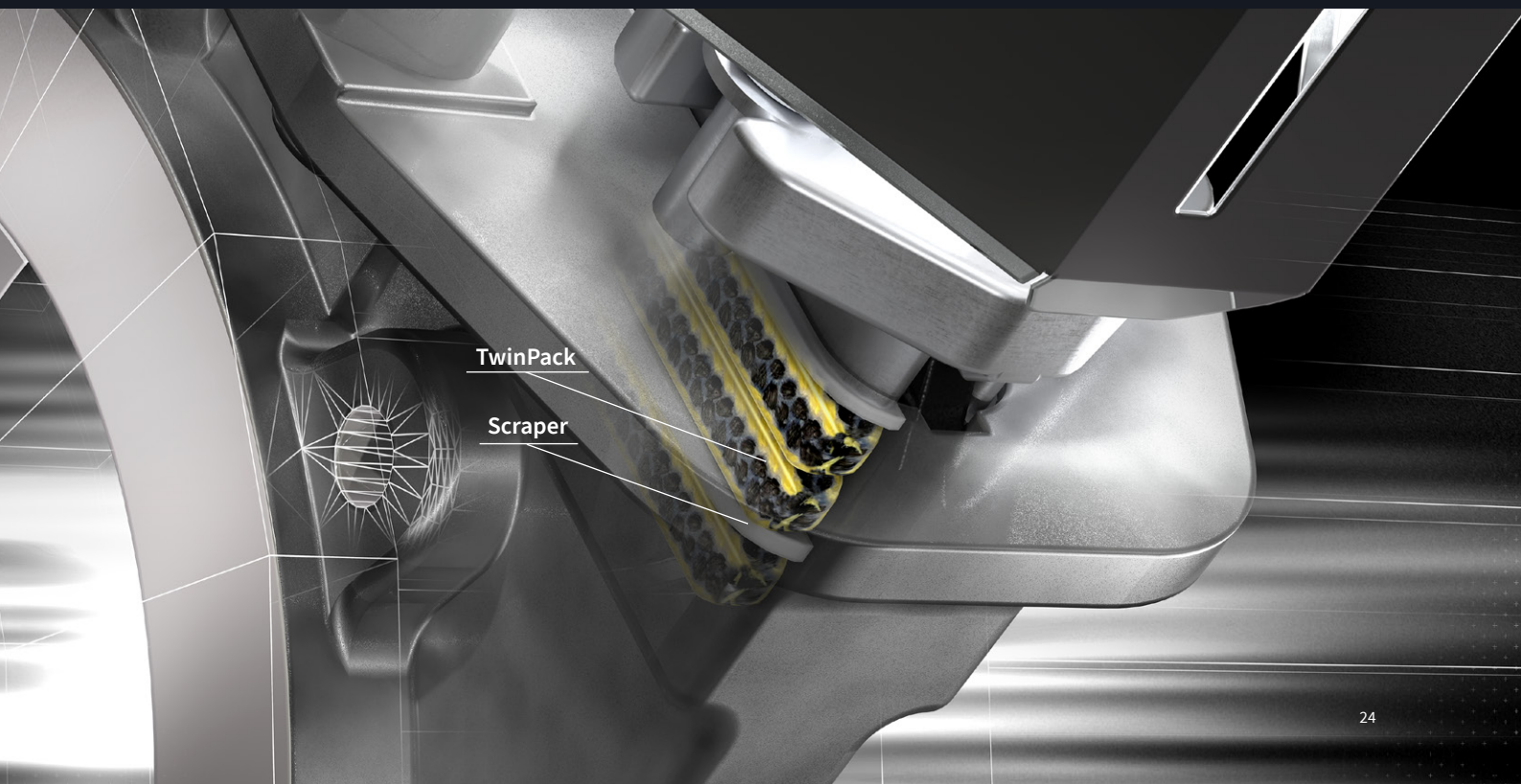

# Material and actuator service temperatures



The following material and actuator temperatures can be used as guidelines to define minimum and maximum temperatures for the knife gate valve. Please feel free to contact Stafsjö for advise.

Valve body/retainer ring materials	Service temperatures	Standard field of use
Duplex stainless steel EN 1.4470	-50 °C - +250 °C / -58 °F - +482 °F	
Hastelloy C276	-30 °C - +425 °C / -22 °F - +797 °F	
Nodular iron EN-JS1050, GGG50	-10 °C - +200 °C / 14 °F - +392 °F	WB11 ≤ DN 300, WB14-L ≤ DN 300, MV-L ≤ DN 300
Nodular iron EN 5.3105	-10 °C - +350 °C / 14 °F - +662 °F	HG-L, MV-L ≥ DN 350, SLF, SLH, SLV, SLX, WB ≥ DN 350, WB14 ≥ DN 350
Super duplex stainless steel EN 1.4469	-50 °C - +250 °C / -58 °F - +482 °F	
Stainless steel EN 1.4408	-50 °C - +400 °C / -58 °F - +752 °F	D2G, HG, HL, HP, HX, JTV, MV, RKO, TV, WB14E, XV
Titanium ASTM B265 Grade 2	-40 °C - +300 °C / -40 °F - +572 °F	HPT
254 SMO stainless steel equivalent	-40 °C - +399 °C / -40 °F - +750 °F	

Gate materials	Service temperatures	Standard field of use
Duplex stainless steel EN 1.4462	-40 °C - +400 °C / -40 °F - +752 °F	JTV, HP, HX ≥ DN 400, SLF, SLH, SLV, RKO
Hard anti-stick coated duplex stainless steel EN 1.4462	-40 °C - +250 °C / -40 °F - +482 °F	SLH
Super duplex stainless steel EN 1.4410	-40 °C - +400 °C / -40 °F - +752 °F	
Stainless steel EN 1.4301	-40 °C - +400 °C / -40 °F - +752 °F	MV-L DN 50-DN 500, RKS, WB, WB11, WB14-L
Stainless steel EN 1.4404	-40 °C - +400 °C / -40 °F - +752 °F	D2G, HG, HL, HX ≤ DN 350, MV-E, TV, WB14E, XV
Stainless steel UNS17400 Type 630 ASTM A693	-18 °C - +300 °C / -0 °F - +572 °F	
Hard anti-stick coated stainless steel UNS17400 Type 630 ASTM A693	-18 °C - +250 °C / -0 °F - +482 °F	SLH, SLX
Titanium ASTM B265 Grade 2	-40 °C - +300 °C / -40 °F - +572 °F	HPT
254 SMO stainless steel or equivalent	-40 °C - +399 °C / -40 °F - +750 °F	

Valve body guiding pad materials	Service temperatures	Standard field of use
Brass	-125 °C - +200 °C / -193 °F - +392 °F	
PEHD	-150 °C - +80 °C / -238 °F - +176 °F	MV DN 400 - 800, XV ≥ DN 500
POM-C	-40 °C - +100 °C / -40 °F - +212 °F	D2G, JTV, MV DN 400 - 800, ≥ 1200, RKO, SLH, SLX, WB ≥ DN 700, WB14E, XV ≥ DN 700
PTFE	-80 °C - +260 °C / -112 °F - +500 °F	HG ≥ DN 250, HL, HP, HX, HPT, MV ≥ DN 900, WB14E

Valve body gasket materials	Service temperatures	Standard field of use
EPDM	-25 °C - +120 °C / -13 °F - +248 °F	WB ≥ DN 700, WB14 ≥ DN 350, WB14E ≥ DN 350
FEPM	-10 °C - + 180 °C / 14 °F - +356 °F	WB11, WB14, WB14E
FPM/FKM	-15 °C - +180 °C / 5 °F - +356 °F	HL, HG ≥ DN 300, HP, HX ≥ DN 350, JTV, MHE DN 800, MV DN 900-DN 1600, RKO ≥ DN 300, SLV DN 700-DN 900, SLF ≥ DN 450, SLH ≥ DN 350, SLX ≥ DN 350, XV ≥ DN 700
Graphite tape	-50 °C - +550 °C / -58 °F - +1022 °F	HG DN 50-DN 150, RKO DN 100-DN 250
NBR	-25 °C - +100 °C / -13 °F - +212 °F	WB ≥ DN 700, WB14 ≥ DN 350, WB14E ≥ DN 350
PTFE	-80 °C - +260 °C / -112 °F - +500 °F	HG DN 200-DN 250, HPT, HX DN 150-DN 300, SLH ≤ DN 300, SLX ≤ DN 300

Seat materials	Service temperatures	Standard field of use
Brass	-125 °C - +200 °C / -193 °F - +392 °F	RKS
EPDM	-25 °C - +120 °C / -13 °F - +248 °F	MV, TV, SLV, SLF, SLH, SLX, WB, WB11, WB14, WB14E
FEPM	-10 °C - + 180 °C / 14 °F - +356 °F	WB11, WB14, WB14E
FPM/FKM	-15 °C - +180 °C / 5 °F - +356 °F	MV
Natural rubber	-25 °C - +80 °C / 5 °F - +176 °F	SLF, SLH, SLV and SLX
NBR	-25 °C - +100 °C / -13 °F - +212 °F	MV, RKS, WB, WB11, WB14, WB14E
Polyurethane	-25 °C - +90 °C / -13 °F - +194 °F	HG, JTV, MV, RKO
PTFE with o-ring NBR	-25 °C - +100 °C / -13 °F - +212 °F	D2G, HG, HL, HP, HPT, HX, MV, RKO, TV, XV
PTFE with o-ring EPDM	-25 °C - +120 °C / -13 °F - +248 °F	D2G, HG, HL, HP, HPT, HX, MV, RKO, TV, XV
PTFE with o-ring FPM/FKM	-15 °C - +180 °C / 5 °F - +356 °F	D2G, HG, HL, HP, HPT, HX, MV, RKO, TV, XV
Stainless steel with grafoil tape	-40 °C - +400 °C / -40 °F - +752 °F	MV, HG
Stainless steel EN 1.4408 with o-ring NBR	-25 °C - +100 °C / -13 °F - +212 °F	MV, HG
Stainless steel EN 1.4408 with o-ring EPDM	-25 °C - +120 °C / -13 °F - +248 °F	MV, HG
Stainless steel EN 1.4408 with o-ring FKM	-15 °C - +180 °C / 5 °F - +356 °F	MV, HG

Box packing materials	Service temperatures	Standard field of use
Graphite (pH range: 2-13)	-200 °C - +600 °C / -328 °F - +1112 °F	
PTFE (pH range: 0-14)	-80 °C - +260 °C / -112 °F - +500 °F	
TwinPack (pH range: 2-13)	-60 °C - +260 °C / -76 °F - +500 °F	All products
WhitePack (pH range: 2-13)	-60 °C - +260 °C / -76 °F - +500 °F	

Box packing scraper materials	Service temperatures	Standard field of use
Brass	-125 °C - +200 °C / -193 °F - +392 °F	
PEHD	-30 °C - +80 °C / -22 °F - +176 °F	MV DN 500-DN 800
PTFE	-80 °C - +280 °C / -112 °F - +536 °F	HX, WB14E
UHMW-PE	-200 °C - +85 °C / -328 °F - +185 °F	SLV, SLF, SLH, SLX, XV ≤ DN 600, WB 350-DN 600, WB11/WB14 DN 200-DN 300

Actuators	Service temperatures	Standard field of use
Auma SA actuators	-30 °C - +70 °C / -22 °F - +158 °F	
Auma GK bevel gears	-25 °C - + 80 °C / -13 °F - +176 °F	
Ceson double-acting hydraulic cylinder	-20 °C - +80 °C / -4 °F - +176 °F	
CFP double-acting pneumatic cylinders	-20 °C - +70 °C / -4 °F - +158 °F	D2G & RKS
CFP single-acting pneumatic cylinders	-20 °C - +70 °C / -4 °F - +158 °F	
Linak LA36 actuator unit	-30°C - +65°C / -22 °F - +149 °F	WB11, WB14, WB14E, MV DN 50-DN 300
Linak control unit	+5°C - +40°C / -41 °F - +104 °F	WB11, WB14, WB14E, MV DN 50-DN 300
PA double-acting pneumatic cylinders	-34 °C - +120 °C / -30 °F to 250 °F	
PA single-acting pneumatic cylinders	-34 °C - +120 °C / -30 °F to 250 °F	
SC double-acting pneumatic cylinders	-30 °C - +100 °C / -22 °F - +212 °F	All products except D2G & RKS

# Automation equipment customized for your process

For decades, we have been providing knife gate solutions to process industries around the world. We are used to adapting the knife gate valves to local requirements. No matter where in the world the plant is located, the products we supply should meet or exceed our customers' expectations.



# Describe your knife gate valve

Following descriptions can be used to briefly define material, actuator and accessories of desired Stafsjö knife gate valve. Please feel free to contact Stafsjö for advise.

**MV-L-200-P-TY-HW-PN10**

Valve type ————

Body material ————

Size ————

Seat ————

Box packing ————

Actuator ————

Flange drilling ————

### Standard configuration

Retainer ring and gate material as well as accessories only has to be mentioned in end of the description if it is different from standard.

**SLV-L-100-E-TY-HWR-ANSI-SP-LDR**

Valve type ————

Body material ————

Size ————

Seat ————

Box packing ————

Actuator ————

Flange drilling ————

Optional accessory ————

Optional accessory ————

### Standard configuration with accessories

In this example the customer also wants to have stem protection and load distribution rings. This is mentioned in end of the description.

**RKO-E-200-U-TY-SC200-PN10/PN10-SV-ILS**

Valve type ————

Body material ————

Size ————

Seat ————

Box packing ————

Actuator ————

Flange drilling ————

Optional accessory\* ————

Optional accessory\* ————

### Standard configuration with optional flange pattern

In this example the customer wants to have PN10 flange pattern on both inlet and outlet/discharge side. This is only possible on RKO DN 100 - DN 200. The accessories are mentioned in end of the description.

\* SV: Solenoid valve Stafsjö standard 220/230 V AC

\* ILS: Inductive limit switches Stafsjö standard 20-250V AC/DC

### Knife gate valve options

D2G
HL
HG
HP
HPT
HX
JTV
JT
MV
RKO
RKS
SLV
SLF
SLH
SLX
TV
XV SL (semi lugged version)
XV FL (fully lugged version)
XV FLD (fully lugged version for dead-end services)
WB
WB11
WB12
WB14
WB14E

### Valve body material options

D	Duplex stainless steel EN 1.4470
E	Stainless steel EN 1.4408
L	Nodular iron EN 5.3105, EN-JS1050, GGG50
SMO	Equivalent material to 254 SMO stainless steel
T	Titanium ASTM B265 Grade 2

See product data sheet for each knife gate valve for available material options.

### Seat material options

E	EPDM
F	FEPM
V	FPM/FKM/Viton
NR	Natural rubber
N	NBR
M	Metal with o-ring NBR (Brass on the RKS valve)
MV	Metal with o-ring FPM/FKM
MHT	Metal with grafoil tape
P	PTFE with o-ring NBR
PE	PTFE with o-ring EPDM
PV	PTFE with o-ring FPM/FKM
PFDA	FDA/EC 1935/2004 approved PTFE with o-ring NBR
PEFDA	FDA/EC 1935/2004 approved PTFE with o-ring EPDM
PVFDA	FDA/EC 1935/2004 approved PTFE with o-ring FPM/FKM
U	Polyurethane

See product data sheet for each knife gate valve for available material options.

### Gland box packing options

TG	Graphite
TF	PTFE
TFFDA	FDA/EC 1935/2004 approved PTFE
TY	TwinPack
TYS	TwinPack with a UHMW-PE scraper
TYPS	TwinPack with PTFE scraper
TYB	TwinPack with brass scraper
WP	WhitePack

See product data sheet for each knife gate valve for available material options.

### Actuator options

BS	Bare shaft, actuator excluded
CW	Chain wheel
CFPXXX	CFP (or PA) double-acting pneumatic cylinder in size XXX
CFPXXXMO	CFP (or PA) double-acting pneumatic cylinder in size XXX with manual override
CFPXXXC	CFP (or PA) double-acting pneumatic cylinder in size XXX including pneumatic cushioning
CFPSOXXX	CFP (or PA) single-acting pneumatic cylinder in size XXX with spring return to open the valve
CFPSCXXX	CFP (or PA) single-acting pneumatic cylinder in size XXX with spring return to close the valve
CFPSOXXXMO	CFP (or PA) single-acting pneumatic cylinder in size XXX with spring return to open the valve and manual override
CFPSCXXXMO	CFP (or PA) single-acting pneumatic cylinder in size XXX with spring return to close the valve and manual override
HL	Hand lever
HC	Stafsjö standard double-acting hydraulic cylinder
HW	Hand wheel with non-rising stem
HWALU	Hand wheel in aluminum with non-rising stem
HWSS	Hand wheel in stainless steel with non-rising stem
HWR	Hand wheel with rising stem
EM	Electrical motor for open-close duty with rising stem. Brand, size, voltage and extra module must always be specified.
EMR	Electrical motor for modulating duty with rising stem. Brand, size, voltage and any extra module must always be specified
LI	Electric motor from LINAK. Control unit must be specified.
PrepEM	The valve is prepared for assembly of electric motors with interface FXX and output drive type A (rising stem) according to ISO 5210.
PrepEMB3	The valve is prepared for assembly of electric motors with interface FXX and output drive type B3 (non-rising stem) according to ISO 5210.
PrepBG	The valve is prepared for assembly of bevel gear with interface FXX and output drive type A according to ISO 5210.
SCXXX	SC double-acting pneumatic cylinder in size XXX (100, 125, 160, 200, 250, 320). Magnetic piston is standard up to Ø 200 barrel size.
SCXXXM	SC double-acting pneumatic cylinder with magnetic piston in size XXX (250, 320)

### Flange drilling options

ANSI150	ANSI/ASME B16.5 Class 150 or B 16.47 Class 150
ANSI300	ANSI/ASME B16.5 Class 300
ASD	AS 2129 Table D
ASE	AS 2129 Table E
ASF/H	AS 2129 Table F/H
BS	BS 10 table D
JIS	JIS B 2238 10K
PN10	EN 1092 PN10
PN16	EN 1092 PN16
PN25	EN 1092 PN25
PN40	EN 1092 PN40
SS	Stafsjö Standard

See product data sheet for each knife gate valve for available flange drilling options. Flange drill pattern on the outlet/discharge side of RKO must also be specified if it is not standard square pattern.

Flange drill pattern on the inlet/seat/tank side of TV must also be specified if it is not Stafsjö standard.

On JTV knife gate valves, keep in mind to also mention if metric or UNC threads is needed.

### Retainer ring options

D	Duplex stainless steel EN 1.4470
E	Stainless steel EN 1.4408
L	Nodular iron EN 5.3105, EN-JS1050, GGG50
SMO	Equivalent material to 254 SMO stainless steel
T	Titanium ASTM B265 Grade 2

See product data sheet for each knife gate valve for available material options. Retainer ring material only has to be specified in end of the description if it is different from standard.

### Gate material and surface treatment options

FAL	Duplex stainless steel EN 1.4462, S32205
EPS	Extra polished surface (max Ra 0,8)
HCR	Hard chromed surface
SF2	Nedox SF2 coating
SMO	254 SMO stainless steel or equivalent
T	Titanium ASTM B265 Grade 2
174ph	Stainless steel UNS17400 Type 630 ASTM A693 hardened 43 HRC
1.4301	Stainless steel EN 1.4301/AISI 304
1.4404	Stainless steel EN 1.4404/AISI 316L

See product data sheet for each knife gate valve for available material options. Gate material and surface treatment only has to be specified in end of the description if it is different from standard.

### Standard accessorie options

ATEX	ATEX approved solution. Category, zone and temperature also have to be specified.
BC	Bottom cover
CoC	Country of Origin Certificate legalized by Chamber of Commerce
CS4	Painted valve parts fulfill in applicable areas corrosion protection against environment according EN ISO 12944, corrosivity category C4 medium
CS5	Painted valve parts fulfill in applicable areas corrosion protection against environment according EN ISO 12944, corrosivity category C5 high.
DC	Deflection cone
DG	Double gland
FC	Floor column to stem extensions
FSAT	Fail-safe solution with air accumulator tank
FAPSAIR	Fully automated purge systems with air purging
FAPS	Fully automated purge systems with water purging
FRL	Filter regulator Stafsjö standard including assembly bracket. Make a note if 1/4" or 1/2" should be supplied.
FRLNPT	Filter regulator Stafsjö standard with NPT threads including including assembly bracket. Make a note if 1/4" or 1/2" should be supplied.
ILS	Inductive limit switch Stafsjö standard. Make a note if it should be for 20 - 250 V AC/DC or 10 - 36 V DC.
JB	Junction box Stafsjö standard.
JBALU	Junction box Stafsjö standard in aluminum.
JBSS	Junction box Stafsjö standard in stainless steel.
LD	Lockout with locking device/pin
LDR	Load distribution rings
MagLS	Magnetic limit switches Stafsjö standard.
MLS	Mechanical limit switch Stafsjö standard.
MSSSP81	Face-to-face dimensions according MSS-SP81.
POS	Brand and type must be specified.
PPS	Purge ports extra, standard positions.
PPC	Purge ports, customized postions. Position and quantity must be specified.
PPCSSPW	Purge ports customized postions including stainless steel pipe works. Position and quantity must be specified.

PrepILS	Hand wheel operated valves is prepared with indicator pin and beams with holes. Brackets for switches excluded.
SBU	Ebro SBU switch box
SBUIO	Ebro SBU IO-Link switch box
SEL	Stem extension long. Extra supports must be specified.
SES	Stem extension short. Extra supports must be specified.
SSPW	Stainless steel pipe works (air tubes)
SP	Stem and piston rod protection/Bellow.
SSP	Stainless steel pillar top works
SSTWLD	Stainless steel top works including lockout
SV	Solenoid valve, Namur interface, Stafsjö standard. Make a note if should be supplied for 24 V DC, 110 V AC or 220/230 V AC.
SVNPT	Solenoid valve, Namur interface, NPT ports, Stafsjö standard. Make a note if should be supplied for 24 V DC, 110 V AC or 220/230 V AC.
SVB	Solenoid valve excluding namur interface, including bracket. Make a note if should be supplied for 24 V DC, 110 V AC or 220/230 V AC.
TAG	Tag plate
RFK	MV reverse flow kit
T-key	Stem extension with a T-key
Vp	V-port in stainless steel
2.2	2.2 test report according to EN 10204
3.1	3.1 inspection certificate according to EN 10204

### Your notes

# WB14E



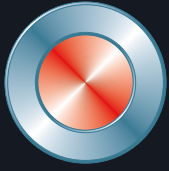

**Stafsjö**<sup>®</sup>  
SINCE 1666



**Valve  
& Automation**  
**Total Valve & Control Solutions**<sup>®</sup>

JOHANNESBURG  
Tel: 011 397 2833

DURBAN  
Tel: 031 579 2593

**South Africa:**  
**0861 103 103**

E-mail: [sales@valve.co.za](mailto:sales@valve.co.za)  
[www.valve.co.za](http://www.valve.co.za)

