

Stafsjö
SINCE 1666

Re-packing instruction

Maintenance instruction for knife gate valves
D2G, HG, HL, HP, HPT, HX, JTV, MV, RKO and RKS

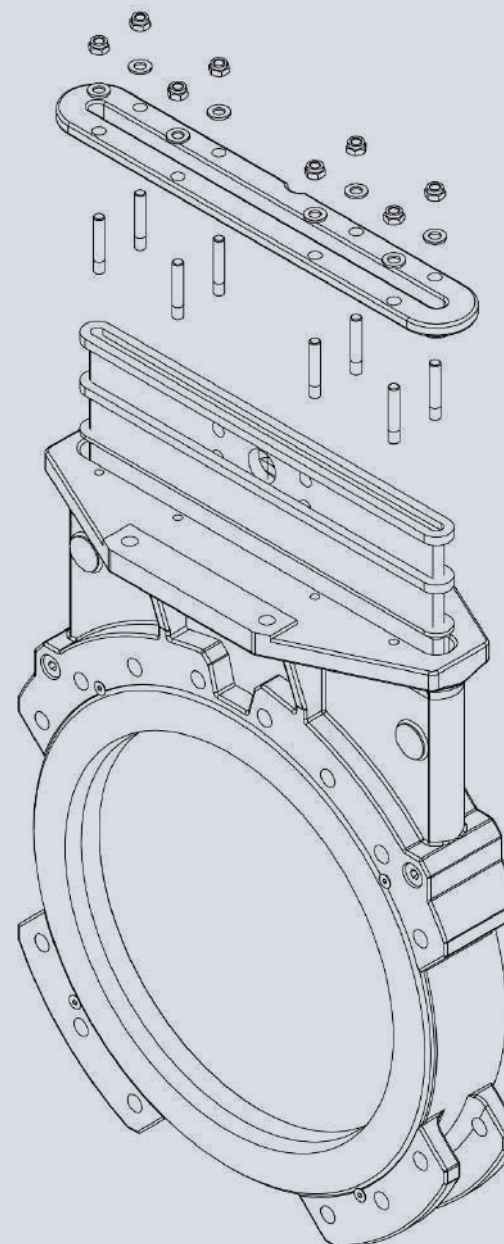

1. Introduction

This is supplementary instruction to relevant knife gate valve maintenance instructions and provide a step-by-step instruction for

A. Gland box packing systems.

B. Gland box packing installation.

C. Retainer ring concept.

	<ul style="list-style-type: none">• Steps and procedures described in this instruction are based on a valve which is not installed in a pipe system.• Follow procedure described in installation and service instruction for the knife gate valve and its actuator.• Maintenance shall be performed by qualified personnel. Qualified are those people who, due to experience, can judge the risk and execute the work correctly and who are able to detect and to eliminate possible risks.• Always consider the application of the valve and carefully prepare relevant personal safety equipment before starting any maintenance.
-----------------------------------------------------------------------------------	-------------------------------------------------------------------------------------------------------------------------------------------------------------------------------------------------------------------------------------------------------------------------------------------------------------------------------------------------------------------------------------------------------------------------------------------------------------------------------------------------------------------------------------------------------------------------------------------------------------------------------------------------------------------------------

2. Spare parts

Each Stafsjö knife gate valve is identified with a label containing the valve item number and its serial number. When corresponding with Stafsjö or our local sales partner, please have this available to make sure you order and receive correct spare parts.

Stafsjö recommends the customer to keep one set of spare parts for each valve type and size in store. Spare parts can be ordered from Stafsjö or our local sales partners.

3. Disassembling of valve parts

See relevant knife gate valve maintenance instruction.

A. Gland box packing systems.

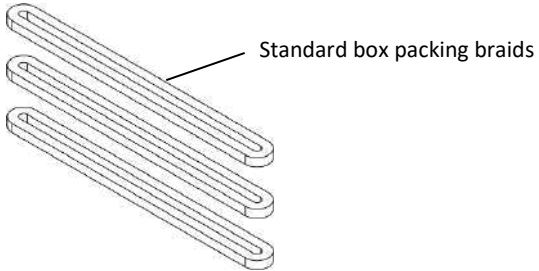
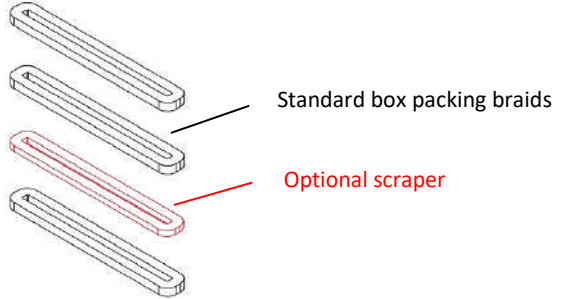
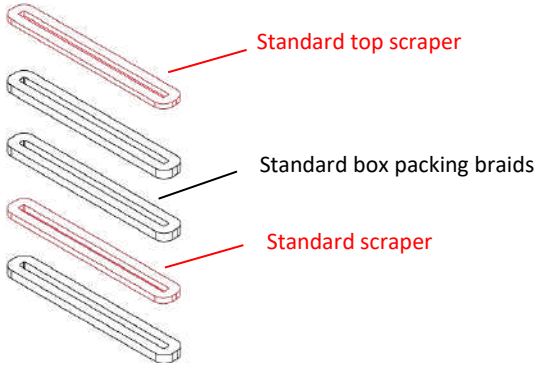
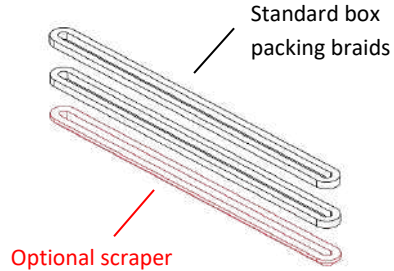
<p>A3 D2G DN 100 - DN 600 (4" - 24")</p>  <p>Standard box packing braids</p>	<p>A3 HG DN 50 - DN 1200 (2" - 28"), HP, HPT DN 300 - DN 1000 (2" - 40")</p>  <p>Standard box packing braids</p> <p>Optional scraper</p> <p>Scraper to be installed as second layer, after first layer of packing braids.</p>
<p>A4 HX DN 150 - DN 900 (6" - 36")</p>  <p>Standard top scraper</p> <p>Standard box packing braids</p> <p>Standard scraper</p> <p>Scraper to be installed as second layer, after first layer of packing braids. Top scraper to be installed on the top of the last layer of packing braids.</p>	<p>A1 MV DN 50 - DN 450 (2" - 18")</p>  <p>Standard box packing braids</p> <p>Optional scraper</p> <p>Scraper with chambered edge should be installed in bottom of the gland box.</p>

A2 MV DN 500 - DN 1600 (20" - 64")

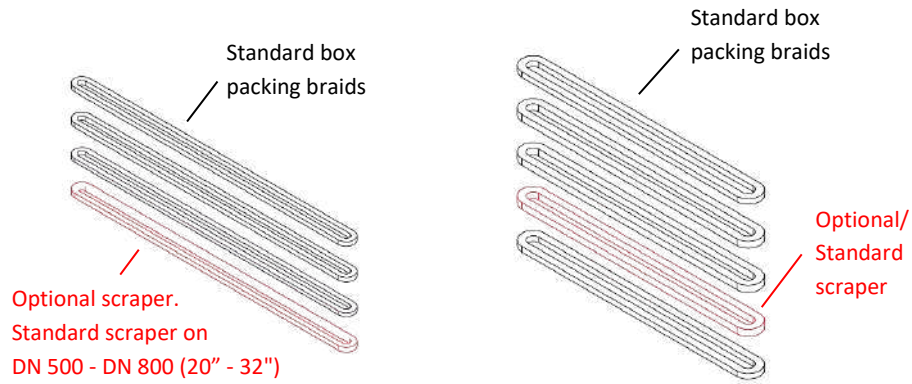

Scraper with chamber edge should be installed in bottom of the gland box.

A flat scraper should be installed in between the box packing braids.

A5 RKO DN 100 - DN 600 (4" - 24"), JTV 250 x 250 (10" x 10")

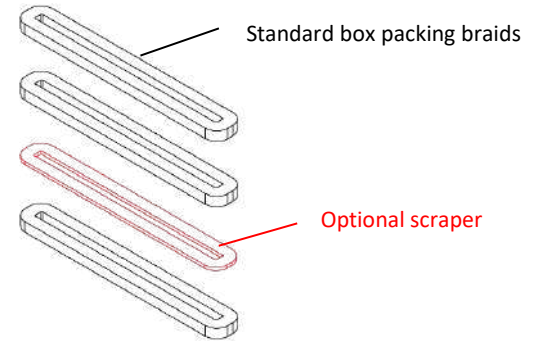

Scraper to be installed as second layer, after first layer of packing braids.

A6 RKS 200x200 - 1000x1000

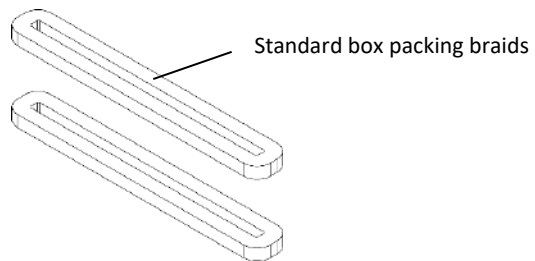

B. Gland box packing installation.

B1 Gland box packing installation

Prepare gland box packing system according section A.

Pre-shape the packing braids to make it easier to install them in the knife gate valve.

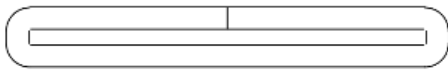

B2 Gland box packing installation

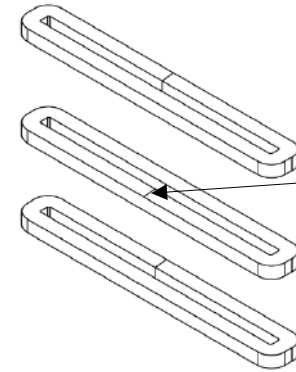

For each packing braid, the ends should be on the opposite side of the previous one.

B3 Gland box packing installation

Use suitable tools to support installation of the packing into the valve gland box/es.
Do not use any sharp or pointed tools that could damage the braid or the gate.

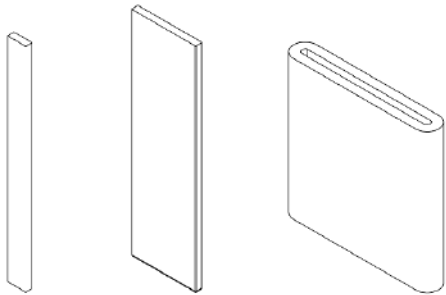

B4 Gland box packing installation

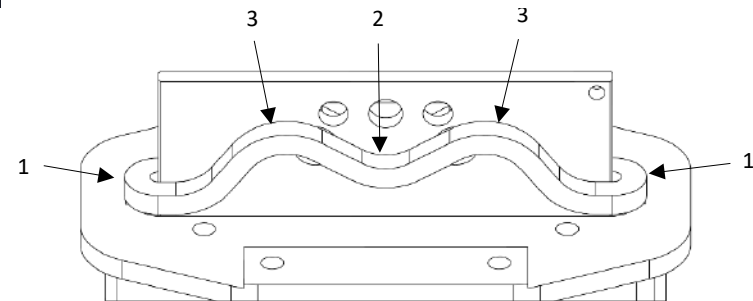

1. Observe potential scraper installation in bottom of the box, see section A.
2. Install the braid into the radius first.
3. Then bring down the overflow in the center to get the "M" shape.
4. Gently press down the rest of the braid until it is in level with top of the gland box.
5. Gently press down the braid to bottom of the gland box.
6. Ensure each braid is compressed individually.
7. Repeat procedure until all braids are in place.

B5

Gland box packing installation

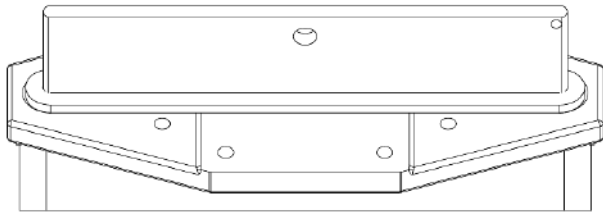

Successful packing installation.

B6

Assembly of the gland

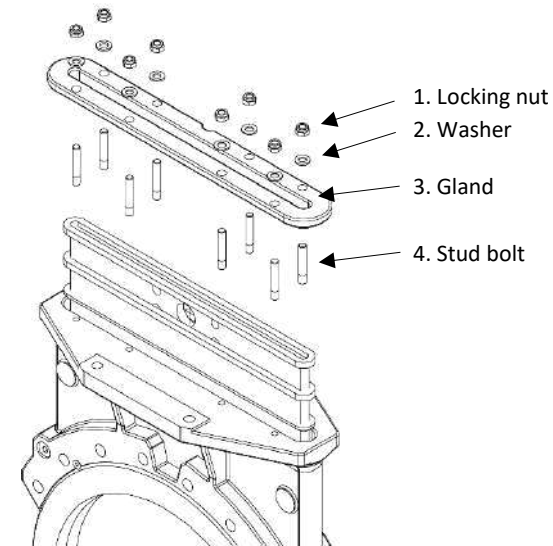

B7

Assembly of the stud bolts

Stud bolts always have a long and a short thread which are divided by a flat surface.

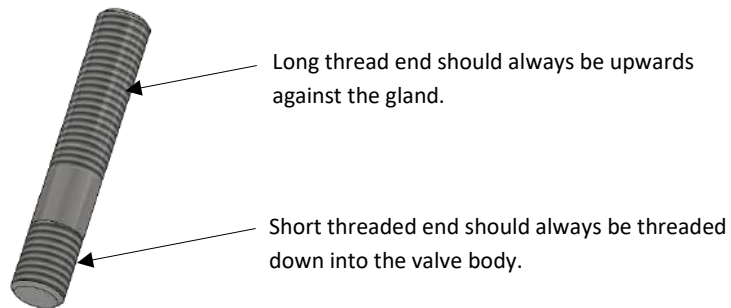

B8

Assembly of the stud bolts

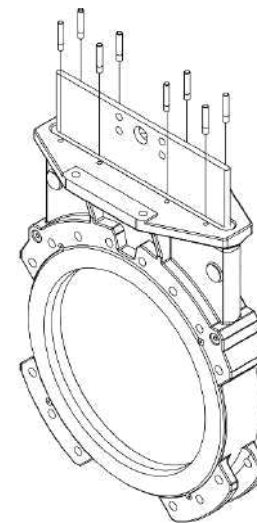

1. Lubricate short thread end of the stud bolt with thread paste.
2. Thread down manually the stud bolt with short threaded end into the valve body. Always find the threads before using machine support. Thread down until flat surface meet the valve body.
3. Lubricate the long thread with thread paste.

B9 Assembly of the gland

Install the gland onto the stud bolts.

1. If gland has a slot, ensure it faces the side of the valve body with a hole on the top of the valve body.

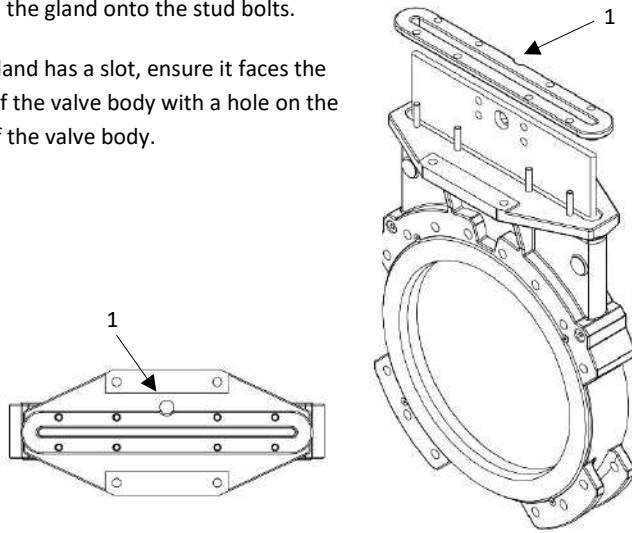

B10 Assembly of the gland

Knife gate valves HG, HP and HX can be supplied with two different glands.

Lockout gland should always be installed valve topworks side.

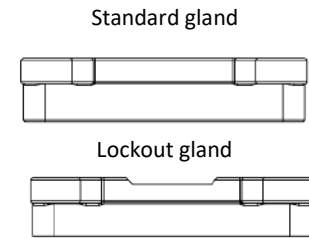

B12 Assembly of the gland

Install washers and nuts onto the stud bolts

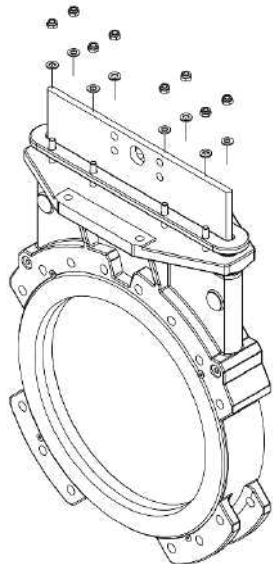

B13 Assembly of the gland

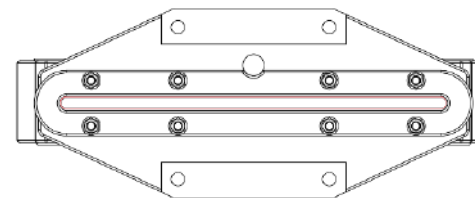

When tightening the nuts, ensure that the gland is centered and has equal distance all around the gate.

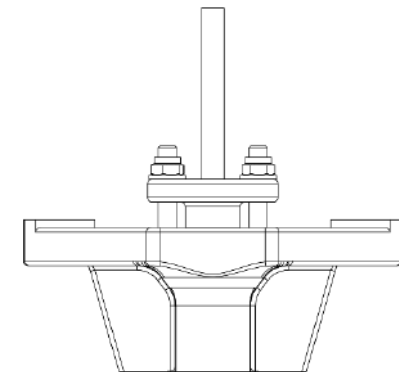

It is also important to ensure gland is even tightened all around the gate.

B14 Assembly of the gland

Tighten the gland nuts evenly crosswise, bit by bit according torques table.
Do not tighten more than necessary!

Check at regular intervals the gland is not misaligned in any direction (See B13).

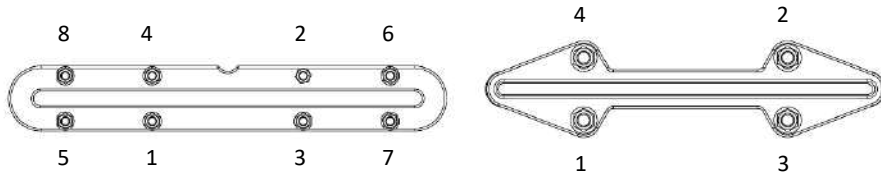

B15 Assembly of the gland – torque table

Recommended maximum gland nuts torque		
Size range	Nm	lbf x ft
DN 50 - DN 80 (2" - 3")	20	15
DN 100 - DN 150 (4" - 6")	25	18
DN 200 - DN 300 (8" - 12")	30	22
≥ DN 350 (14")	35	26

B16 Assembly of the gland – torque table for HP and HX

Recommended maximum gland nuts torque for HP and HX		
Size range	Nm	lbf x ft
DN 50 - DN 80 (2" - 3")	25	18
DN 100 - DN 150 (4" - 6")	30	22
DN 200 - DN 1000 (8" - 40")	35	26

B17 Assembly of the gland – torque table for RKS

Recommended maximum gland nuts torque for RKS – not installed		
Size range	Nm	lbf x ft
200x200 - 1000x1000 (8" x 8" - 40" x 40")	10	7

Recommended maximum gland nuts torque for RKS – installed in between flanges		
Size range	Nm	lbf x ft
200x200 - 1000x1000 (8" x 8" - 40" x 40")	25	18

C. Retainer ring concept

C1 Retainer ring concept

The retainer ring holds the seat in exact correct position as the gate strokes. It is mechanically locked, and it can easily be removed from the valve for seat change. Both the retainer ring and seat is available in several different materials.

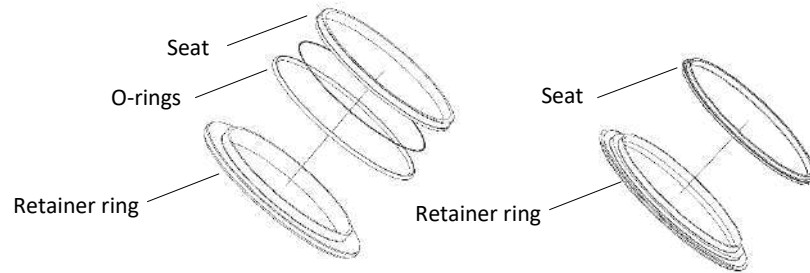

C2 MV with retainer ring, PTFE seat and back-up o-rings

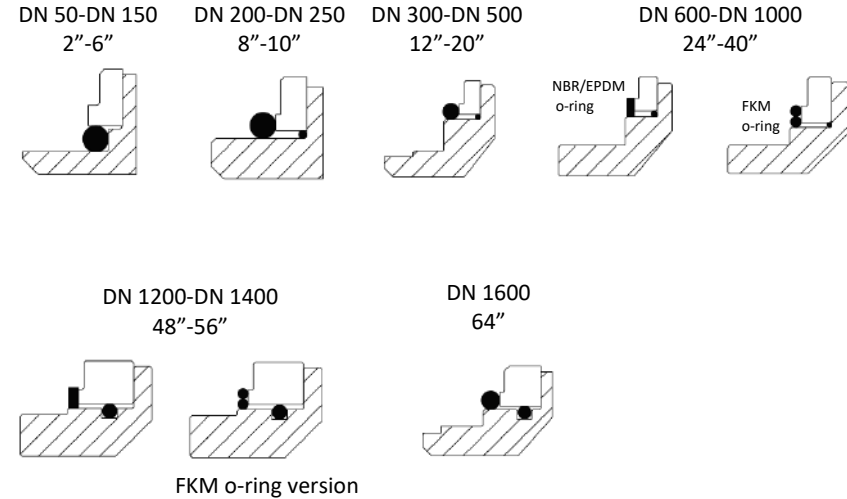

C3 HG and HP with retainer ring, PTFE seat and back-up o-rings

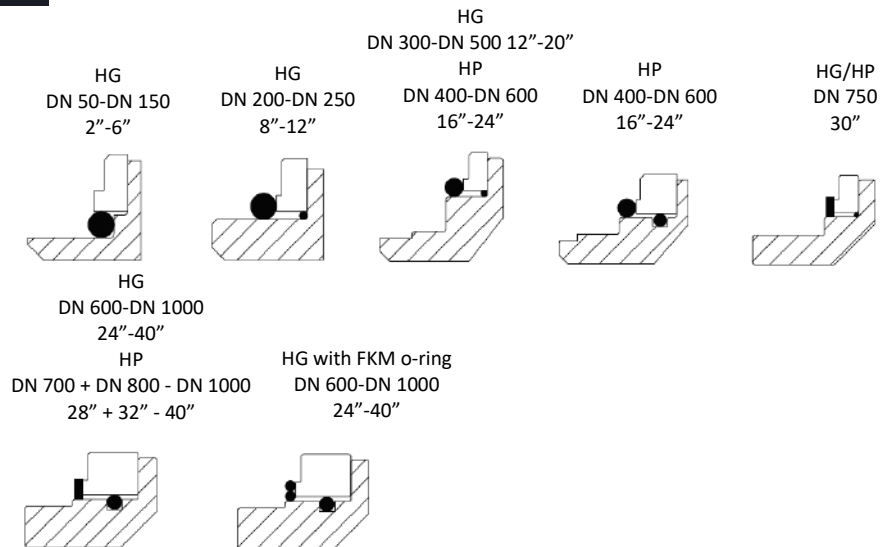

C4 RKO with retainer ring, PTFE seat and back-up o-rings

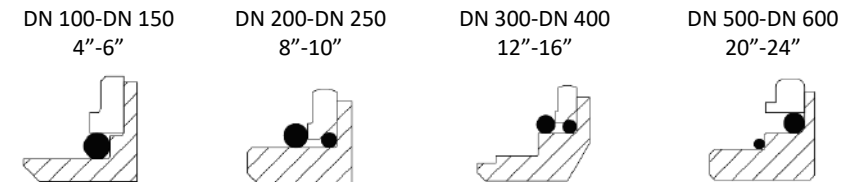

C5

HX with retainer ring, PTFE seat and back-up o-rings

DN 150
6"

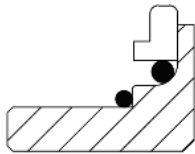

DN 200-DN 900
8"-36"

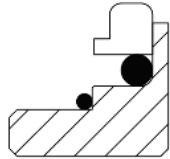

C6

D2G and HL with retainer ring, PTFE seat and back-up o-rings

XV/D2G
DN 65-DN 350
2.5"-14"

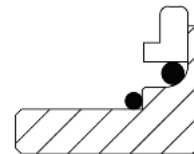

XV/D2G/HL
DN 400-DN 1000
16"-40"

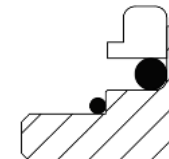

C7

JTV with retainer ring, polyurethane seat and back-up o-rings

250x250
10"x10"

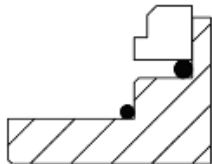

C8

Polyurethane seat version

One piece item where retainer ring and seat is one and the same piece. Additional o-rings are not needed.

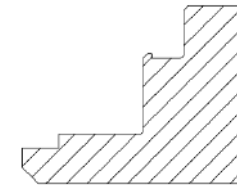

C9 HG and MV metal seat version

One piece item where retainer ring and seat is one and the same piece.

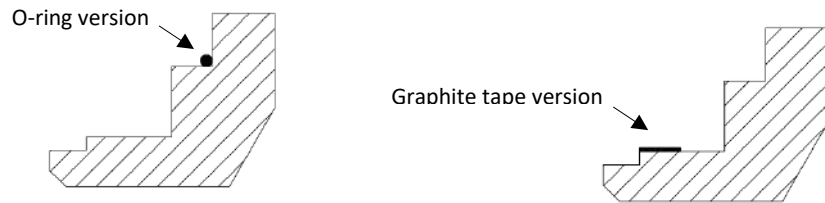

C10 MV with retainer ring, EPDM, NBR or FKM rubber seat



C11 Apply grease

To simplify installation of the seat and retainer ring into the valve body, we recommend applying grease:

- On the o-rings.
- On side of the seat facing the valve body, not on side facing the gate.
- Ensure to use grease approved for the seat material. OKS 476 – Multipurpose Grease or equal is recommended.

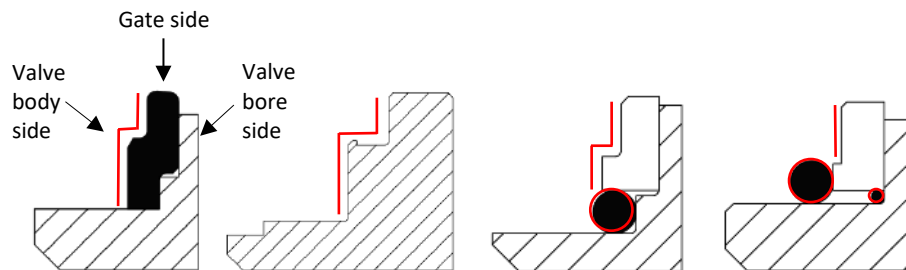

C12 Assemble the retainer ring kit into the valve

See relevant valve maintenance instruction.

