

Model 1078

Vacu-Gard Pilot Operated Blanketing Valve

SECTION I

I. DESCRIPTION AND SCOPE

The Model 1078 Vacu-Gard is a pilot operated blanketing valve intended for installation on top of medium to large storage tanks. Available with either FNPT or flange end connections, 1" size available with

150 lb. integral cast flanges. 1" size valve bodies are cast 316 stainless steel (CF3M). 2" size valve bodies are available in cast carbon steel (WCB) or stainless steel (CF3M). All sizes have 316 SST Trim.

SECTION II

II. PRIOR TO INSTALLATION

Clean out blanket gas supply lines prior to valve installation to get rid of dirt, sand, loose scales and other foreign particles trapped in the piping. This is particularly true for new tanks and/or new piping. One way to accomplish this is to blow out the lines from the supply side up to the connection to the Vacu-Gard inlet.



CAUTION

Follow your company's safety procedures to avoid injury to personnel or damage to equipment.

SECTION III

III. INSTALLATION

It is always good practice to install a main line filter upstream of any tank blanketing valve. The element should be approximately 5-40 microns with a flow capacity at least equal to or greater than that of the Vacu-Gard.

The valve should be installed in the normal upright position. The inlet is horizontal and the outlet is vertical downward. An optional horizontal outlet is available for the remote sensing design only. All outlet piping from the valve body to the vessel must be at least as large or larger than the outlet port in the body. Keep piping as short as possible for best valve performance.

For Remote Sensing:

The sense line should be a 1/2" O.D. tube (or larger) and the length should not exceed fifteen feet. Longer lengths may be used with larger diameter sense lines. The sense line should slope downward from the pilot to the tank to allow condensate, if any, to drain back into the tank. (The sense port is the port on the side of the pilot body marked with an "S". A "tee" may be added to the sense port for gauging pressure in the vessel.)

For Dip-Tube Sensing:

The integral dip-tube line must protrude into the tank at least 6" below the roof.

NOTE: The port at the end of the main valve body opposite the inlet is not a sense port. This port should not be used for pressure gauging since the pressure at this point may be higher than the maximum tank pressure and may cause damage to the gauge.

NOTE: The sense chamber is not a dead-ended chamber. In addition to the main flow and pilot flow when the valve is open, there is also a very small flow from the pilot valve into the vessel through the sense connec-

tion. Therefore, the sense tube must be large enough so that the flow will not be restricted. Premature closing of the valve may occur if excess pressure builds up in the sense chamber due to a sense line that is too small.

 **CAUTION**
A pressure/vacuum relieving device large enough to vent excess pressure and to serve as an emergency vacuum breaker must be installed to protect the tank.

 **CAUTION**
DO NOT overtighten threaded connections since damage or breakage may result. Wrap all NPT threads with TFE tape. Apply anti-seize compound on bolt threads.

SECTION IV

IV. START-UP

Operation of the Model 1078 is automatic once the set pressure has been established. (The set pressure is usually bench-set at the factory prior to shipment.) The set pressure may be approximated on the bench or set after the valve has been installed. If the set pressure is to be made after valve installation, the adjusting screw should be backed off before applying inlet pressure to the valve. **NOTE:** The set pressure is defined as the pressure at which the valve should be fully closed on increasing tank pressure.

Refer to applicable drawing dependent on sensing style. Temporarily keep valve A closed. Use an appropriate pressure indicating instrument for G2 to measure the pressure in the vessel. (For external sensing open valves C and E, then valve B.) Now very slowly open valve A while watching gauge G2. NEVER SLAM OPEN VALVE A! The Vacu-Gard should close when the tank pressure reaches the set pressure of the pilot. To adjust the set pressure, remove the hex cap at the top of the pilot and loosen the jam nut around the adjusting screw. Clockwise rotation of the adjusting

screw will increase the set pressure. Counter clockwise will decrease the pressure provided there is a manual valve to vent the excess pressure. Do not set the set pressure beyond the nameplate range. Tighten the jam nut after adjustments are made and replace the hex cap.

 **CAUTION**
DO NOT exceed the maximum inlet pressure on the nameplate, as the valve may not open in time. Likewise, the minimum nameplate pressure must be maintained, otherwise the valve may not open.

In the event that the adjusting screw is backed out eliminating the spring compression, intentionally or unintentionally, the valve will begin to open when the tank pressure reaches about 1" w.c. vacuum.

VACUUM SET VALVES: For valves that are set to open and close on vacuum - a clockwise rotation of the adjusting screw will set the valve to open closer towards atmospheric pressure (less vacuum).

SECTION V

V. SHUT-DOWN

Refer to drawings on page 3. Close inlet block valve A. Remove plug D slowly from the body to allow any pressure that maybe trapped in the body to vent to atmosphere. If installation has remote sensing, close valve B and valve E. The Model 1078 can now be removed from the system or repaired while in place.

 **CAUTION**
Follow your company's safety procedures to avoid injury to personnel or damage to equipment.

Normal Installation - Remote Sensing Model 1078 Pilot Operated Vacu-Gard

It is recommended that the Vacu-Gard be installed approximately one foot above the seat of the relief valve to avoid getting liquid into the Vacu-Gard if the tank is overfilled.

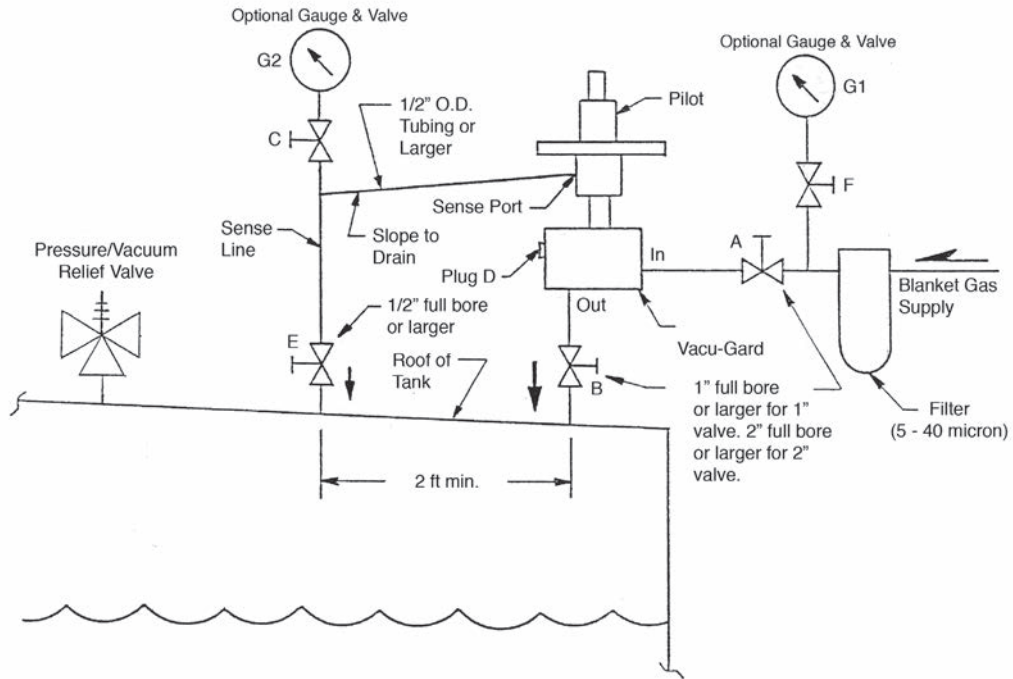

Installation - with Integral Dip-Tube Sensing Model 1078 Pilot Operated Vacu-Gard

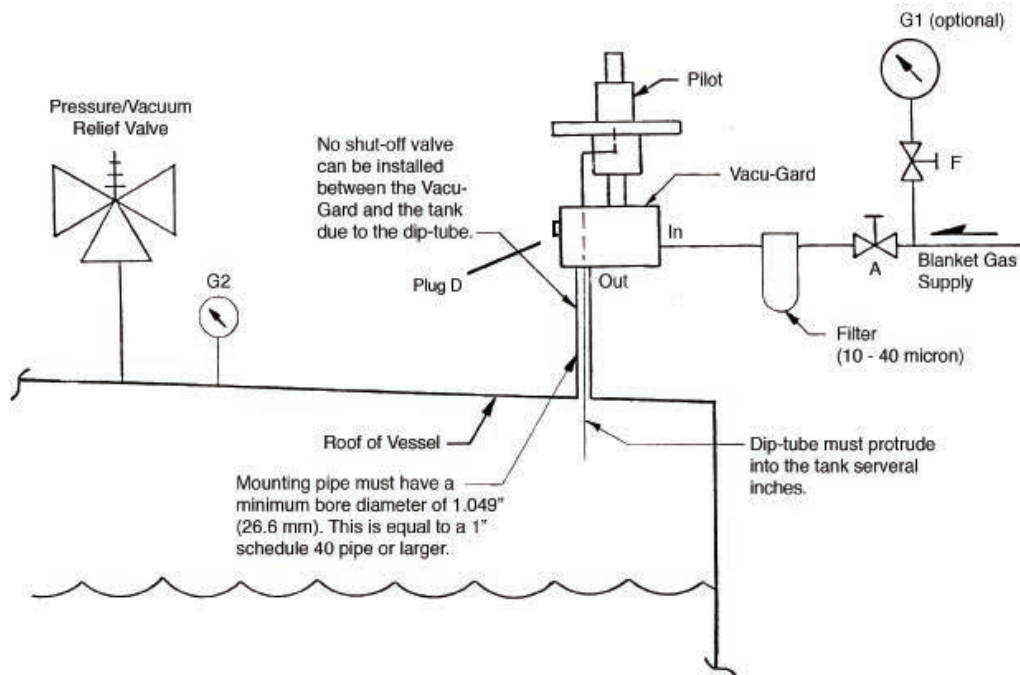

SECTION VI

VI. MAINTENANCE

The Model 1078 should be periodically actuated and all sliding surfaces and seals lubricated to ensure smoothness of operation. The frequency required depends on the severity of the service conditions. At least once a year is recommended.

Maintenance procedures hereinafter are based upon removal of the unit from the vessel where installed. Install the body in a vise with the pilot upwards. Loosen the tubing fittings and remove all tubing (115).

Refer to the appropriate drawings for disassembly.



CAUTION

If the valve is to be disassembled, first make sure all pressure to the blanketing valve is blocked and any pressure trapped inside the valve is vented safely out. Refer to your company procedure for any special precautions when handling toxic or hazardous materials.

Pilot Internals: *NOTE: The working components and o-rings within the pilot body may be inspected and replaced without the need to take apart the diaphragm case assembly.*

To Replace the Pilot Body Internals Only:

NOTE For 1" size: *Unscrew and remove the lower portion of the filter canister and filter element from the filter assembly (202).*

Grab the pilot diaphragm case assembly with hands and rotate the pilot assembly counter clockwise CCW to remove the pilot body from the pilot mount (on 1" SIZE); from the pilot connector (on 2" SIZE). **NOTE:** *Be careful not to drop internal components as the pilot body is lifted up. Return spring (25) could dislodge the spindle (20), guide pin (24) and spacer (26) as the pilot body and pilot mount separate.*

Remove o-rings (21,22 and 35). Clean and inspect trims parts for wear. Replace if worn.

Install new o-ring (35) around the groove adjacent to the threads on pilot mount (37)(on 1" SIZE); on pilot connector (47) (on 2" SIZE). Install o-ring (21) around the outside groove of the spindle (20). Install o-ring (22) in the internal groove at the lower end of the spindle. **NOTE: O-RINGS MUST BE ORDERED FROM THE FACTORY.**

Position spacer (26) on top of the pilot mount / connector. Insert the spring (25) and guide pin (24) inside the spindle (20) and place these parts into the

center of the spacer with the small end of spindle oriented up.

Lower the pilot body over the top of the spindle. Ensure that the top of the spindle enters into the small opening in the center of the body cavity. Press down on the top of the pilot body and slowly, evenly rotate CW to engage the threads on the pilot mount or connector to the pilot body. It is not necessary to use any tool to ensure a tight seal between the pilot body and the pilot mount / connection.

To Disassemble the Diaphragm Case Assembly:



WARNING

SPRING UNDER COMPRESSION. Prior to removing diaphragm case bolts, relieve spring compression by backing out the adjusting screw. Failure to do so may result in flying parts that could cause personal injury.

Re-install filter element and canister to filter assembly. Re-connect tubing and fittings.

Rotate closing cap (1) CCW to remove. Rotate jam nut (3) CCW two rotations and then back out the adjusting screw (2). Place a set of match marks between the upper and lower cases. Remove nuts (15), lock washers (12), flat washers (41) and cap screws (11) from perimeter of diaphragm case (9). Lift up to remove upper case assembly. Set spring (7) and spring button (6) aside. Lift ring gasket (14) and diaphragm assembly up and remove from lower case (9).

To replace gasket (8) - remove cap screws (11) and lock washers (12) from the center of the lower case. At re-assembly torque these cap screws 13-15 ft-lbs.

To Disassemble Pilot Diaphragm Assembly:

Secure hex head of center bolt (17) in soft jawed vise. Rotate nut (15) CCW and remove nut, lock washer (12) and flat washers (33). Lift up to remove upper support plate (16), gasket (18) and diaphragm (13). Lift up to remove lower support plate (16) and gasket (18). Clean and inspect parts, replace diaphragm and gasket. At re-assembly torque nut (15) 4-5 ft-lbs.

To Disassemble the Main Valve Assembly:

For 1" SIZE: Rotate the four cap screws (11) CCW and remove washers (12, 41) that hold the mounting plate (36) to the main body. Carefully lift the pilot mount (37) upwards to remove from the main body. The piston



CAUTION

If the piston (107) does not remain in the main body cavity, it may slowly slide out from the housing. Make sure the piston does not fall out of the housing while retracting the housing from the main body.

(107), o-rings (103, 104 and 135) and other internal parts should come out with the pilot mount.

To access o-rings (105, 106), pull the piston (107) out of the pilot mount and remove the screw (111) and lock washer (112). The flow plug (109) will come out with a straight pull.

For 2" SIZE: Place a set of match marks between the main body (108) and the pilot housing (124). Rotate the six cap screw (129) CCW and remove lock washers (130) that hold the piston housing (124) to the main body (108). Carefully lift the pilot housing upwards to remove from the main body. To access the o-rings (105,106), pull the piston (107) out of the piston housing or remove it from the main body cavity. Rotate cap screw (111) CCW to remove lock washer (112). The flow plug (109) will come out with a straight pull.

To access seat ring seal (132), rotate cap screws (11) CCW and remove lock washers (12) from seat ring (131). Lift up to remove the seat ring from the main body. If the seat ring is difficult to remove, thread two cap screws into the threaded holes and remove the seat ring by lifting upwards on the cap screws.

Replace all parts that show signs of damage or excessive wear. Make sure the material for new parts is suitable for the service, especially elastomeric components. If an o-ring needs to be replaced, be sure to use the correct size and material. Prior to reassembly, make sure all parts are clean and free of contamination and seating surface is free of scratches.

To Reassemble the Valve - utilize specific instructions as follows:



CAUTION

DO NOT overtighten threaded connections since damage or breakage may result. Wrap all NPT threads with TFE tape. Apply anti-seize compound on bolt threads. Very lightly lubricate all o-rings with a lubricant that is compatible with the service, sealing surfaces of gaskets and diaphragms also.

MAIN VALVE: Install the body in a vise with the large opening of the body upwards. Lightly lubricate all o-rings as mentioned above. Prior to installing the flow plug (109) on the piston (107), place o-ring (106) on the groove on the OD of the piston . Install o-ring (105)

in the recess in the end of the flow plug (109). Grasp the flow plug and push it into the shallow cavity end of the piston. Slide lock washer (112) on screw (111) and install screw through hole in flow plug (109) into the piston (107). **For 1" SIZE** torque the screw to 8-10 ft-lbs. **For 2" SIZE** torque the screw to 13-15 ft-lbs. **NOTE:** The size of the flow plug is stamped on the flat end. See TABLE 1.

For 1" SIZE: Install o-ring (135) in the groove inside the pilot mount (37). Next install o-ring (103) in the groove on the outside of the piston (107). Lightly grease the O.D. of the piston and the I.D. of the pilot mount. Install o-ring (104) on the lip inside the cavity of the body. Slide mounting plate (36) over end of pilot mount. Place spring (102) on top of piston and slide spring / piston into pilot mount. Push the piston in against the spring several times to ensure there is no undue binding. Guide the pilot mount, with the piston inside, into the main body cavity. Install flat washers (41), lock washers (12) and cap screws (11) and tighten the cap screws enough to hold the pilot mount against the main body to prevent the mount from turning.

For 2" SIZE: Install the seat o-ring (132) in the groove in the main body cavity. Place seat ring (131) over the o-ring, install the four lock washers (12) and cap screws (11) through the holes in the seat ring. Be sure the flat side of the seat ring is up. Torque cap screws to 13-15 ft-lbs.

Lightly grease the O.D. of the piston (107) and I.D. of the piston housing (124). Install o-ring (135) in the groove in the piston housing. Next install o-ring (103) in the groove on the outside of the piston. Before placing the piston into the main body cavity, ensure the o-ring (135) seats properly into the piston housing and the piston can slide smoothly in the housing. To check this, insert the spring (102), followed by the piston, into the piston housing. Push the piston in against the spring several times to ensure there is no undue binding. If there is no binding, the piston can then be removed from the housing and placed in the main body.

Set the piston (107) on the seat ring (131) inside the main body cavity. Place spring (102) into the cavity of the piston. Install o-ring (104) under the flange of the piston housing (124). Carefully guide the piston housing over the piston and into the main body cavity. Ensure the piston slides properly into the housing. Align the match marks between the body and the pilot housing. Install the six lock washers (130) and cap screws (129) to secure the housing to the main body. Reinstall pilot connector (47) into the top of the pilot housing (124) if it was removed previously.

PILOT INTERNALS: Install new o-ring (35) around the groove adjacent to the threads on pilot mount (37)(for 1" SIZE); on pilot connector (47) (on 2" SIZE). Install o-ring (21) around the outside groove of the spindle (20). Install o-ring (22) in the internal groove at the lower end of the spindle. **NOTE: O-RINGS MUST BE ORDERED FROM THE FACTORY.**

Position spacer (26) on top of the pilot mount / connector. Insert the spring (25) and guide pin (24) into the spindle (20) and place these parts into the center of the spacer with the small end of spindle oriented up. Lower the pilot body over the top of the spindle. Ensure that the top of the spindle enters into the small opening in the center of the body. **NOTE: The lower diaphragm case may not have been removed from the pilot body.**

Press down on the top of the pilot body or center of the lower diaphragm case and slowly and evenly rotate CW to engage the threads on the pilot mount or connector to the pilot body. It is not necessary to use any tool to ensure a tight seal between the pilot body and the pilot mount / connection.

NOTE: The inlet for the pilot body should be in-line and directly above the inlet of the main body. If the pilot ports need re-positioning:

For 1" SIZE: Loosen the cap screws (11) of the mounting plate and turn the pilot mount to orient the pilot ports in the proper direction. Re-tighten the cap screws to 13-15 ft-lbs.

For 2" SIZE: Use a combination of tightening the pilot connector (47) onto the piston housing (124) and/or rotating the piston housing one bolt hole. Tighten the cap screws to 15-18 ft-lbs.

For DIAPHRAGM ASSEMBLY: Install center bolt (17) in a vise with the threaded end up. Install one bolt gasket (18) between the center bolt and the lower support plate (16) as shown on the drawing. **NOTE: The support plate should be install with the smooth side up.**

Lay the diaphragm (13) on top of the lower support plate. **NOTE: Place diaphragm with the flute facing up for pressure set point or facing down for vacuum set point.**

An identical gasket (18) is used between the upper surface of the sense diaphragm (13) and the bottom side of the upper support plate (16). **NOTE: The support plate should be install with the smooth side down. This is to ensure a tight squeeze on both sides of the sense diaphragm to effect a tight seal.**

Install washers (33), lockwasher (12) and nut (015). Torque nut 13-15 ft-lbs. Place the diaphragm assembly on the lower case and align the bolt holes. Align the holes in the ring gasket (14) and place it on top of the diaphragm assembly. Position spring (7) in the center of the diaphragm assembly.

NOTE: Washers are used to center the lower end of the spring. It may sometimes be necessary to "thread" the spring onto the washer or onto spring button (6). You will find that turning the end of the spring in one direction against the spring button or washers will tend to close the coils and make installation more difficult. However, turning the spring in the opposite direction will tend to open the coils for easier installation.

Apply anti-seize compound to the recess in the spring button (6) and set spring button on top of the spring.

Align the match marks between the upper and lower cases and place the upper diaphragm case assembly on top of the ring gasket (14). **NOTE: The vent outlet for the upper case should align with the pilot body's inlet.**

Install cap screws,(11), washers (12) and nuts (15). Tighten to 13 - 15 ft-lbs. Thread adjusting screw (2) with jam nut (3) into the spring bonnet (5). Install closing cap (1).

Reconnect all tubing, Ensure all tubing is clean and unobstructed.

TABLE 1

**Identification Grooves for reduced flow plugs for verification when the valve is fully assembled.
1" and 2" Vacu-Gards**

Flow plugs are steel stamped with their size on the flat tip as follows:

1" Size	2" Size
100	100
75	80
50	60
25	40
10	20

This number represents the percentage of maximum flow that is allowed through the valve. The number is marked on the flat tip of the plug and is not visible when the valve is assembled. Therefore all flow plugs (except the 100% plug) are marked with circumferential grooves that are visible from the inlet port of a fully assembled valve. The identifying grooves are as follows:

FLOW PLUG SIZE		
No. of Grooves	1" Size	2" Size
None	100% (barely visible)	100% (not visible)
1	75%	80%
2	50%	60%
3	25%	40%
4	10%	20%

SECTION VII

VII. ORDERING INFORMATION

NEW REPLACEMENT UNIT vs PARTS "KIT" FOR FIELD REPAIR

To obtain a quotation or place an order, please retrieve the Serial Number and Product Code that was stamped on the metal name plate, attached to the unit. This information can also be found on the Bill of Material ("BOM"), a parts list that was provided when unit was originally shipped. (Serial Number typically 6 digits).

Product Code

NEW REPLACEMENT UNIT:

Contact your local Cashco, Inc., Sales Representative with the Serial Number, Product code and the pressure/vacuum settings. With this information they can provide a quotation for a new unit including a complete description, price and availability.

that was provided when unit was originally shipped.

If the "BOM" is not available, refer to the cross-sectional drawings included in this manual for part identification and selection.

A Local Sales Representative will provide quotation for appropriate Kit Number, Price and Availability.

 CAUTION
<p>Do not attempt to alter the original construction of any unit without assistance and approval from the factory. All purposed changes will require a new name plate with appropriate ratings and new product code to accommodate the recommended part(s) changes.</p>

PARTS "KIT" for FIELD REPAIR:

Contact your local Cashco, Inc., Sales Representative with the Serial Number and Product code. Identify the parts and the quantity required to repair the unit from the Bill of Materials sheet

SECTION VIII

VIII. TROUBLE SHOOTING GUIDE

1. Vacu-Gard will not open.

Possible Cause	Remedy
A. Incorrect sense line connection.	A1. Check sense line and be sure it is connected from the sense port on the Vacu-Gard to the tank. A2. Check sense line and shut-off valve for size and configuration to prevent pressure drops and trapped condensate.
B. Sense line is clogged.	B1. Check sense line and sense port for blockage.
C. Improper inlet and/or outlet connection.	C1. Check and be sure supply line is connected to inlet of Vacu-Gard and outlet of Vacu-Gard is connected to tank, making sure it is not reversed.
D. Loss of supply pressure.	D1. Check supply pressure and see that it is within the range stated on nameplate.

2. Vacu-Gard will not close.

Possible Cause	Remedy
A. Sense line not installed.	A1. Check that the sense line is properly connected.
B. Vacu-Gard set pressure is higher than or too close to the set pressure of the pressure relieving devices.	B1. Check settings of valves and adjust if needed. The pressure relieving devices must be set higher than the Vacu-Gard setting. The greater the spread the better.
C. Blanket gas is escaping from opening in tank.	C1. Be sure all openings such as pressure relieving devices, gauge hatches, etc., are closed and working properly.
D. Malfunction of pressure relieving devices.	D1. Check operation of pressure relieving devices.
E. Blanket gas is escaping from faulty piping or connections.	E1. Check all piping and connections for tightness.
F. Foreign particles trapped in Vacu-Gard.	F1. Check Vacu-Gard for dirt and debris. (See Maintenance Section for disassembly and reassembly.)
G. Pilot inlet port is clogged.	G1. Check pilot inlet port, filter and tubing.
H. Vacu-Gard has loose connections.	H1. Check and make sure all Vacu-Gard connections are tight.

3. Vacu-Gard cycles rapidly.

Possible Cause	Remedy
A. Shut-off valve at outlet is restricting flow.	A1. Be sure shut-off valve at outlet is full bore or larger.
B. Vacu-Gard set pressure too close to the set pressure of the pressure relieving devices.	B1. Check settings of valves and adjust if needed. The pressure relieving devices must be set higher than the Vacu-Gard.
C. Sense or flow line pipe is undersized.	C1. Check all piping connected to Vacu-Gard for size and configuration to prevent pressure drops and trapped condensate.

4. Vacu-Gard closes but will not shut-off tight.

Possible Cause	Remedy
A. Worn o-rings or seat surfaces.	A1. Replace worn parts. (See Maintenance Section for disassembly and reassembly.)
B. Foreign particles on o-rings or seat surfaces.	B1. Clean and lubricate parts. (See Maintenance Section for disassembly and reassembly.)
C. Loose connections on Vacu-Gard.	C1. Check all connections for tightness.

**1" Model 1078 Remote Sense
Horizontal or Vertical Outlet**

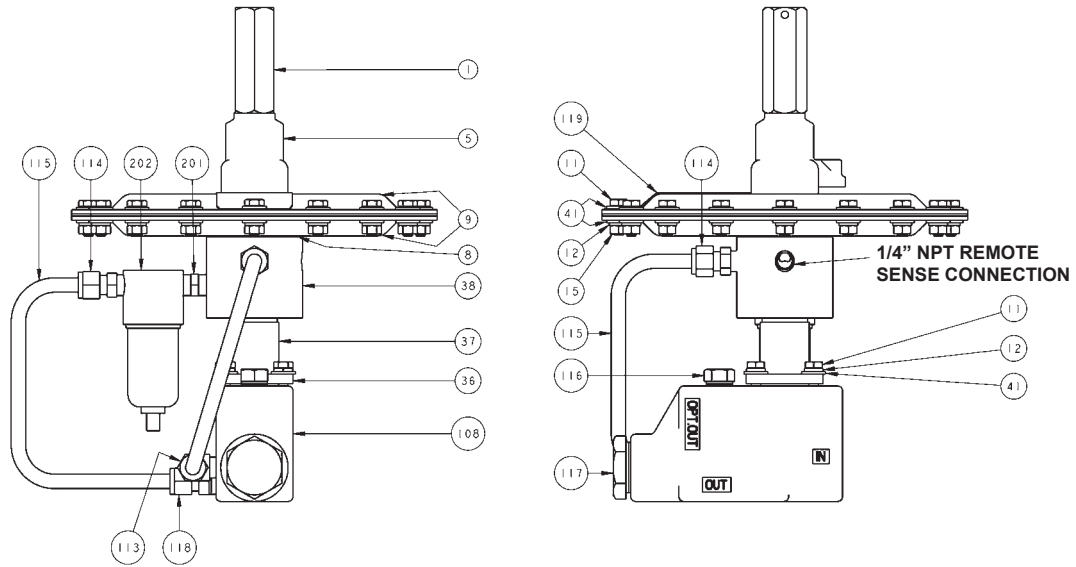

**1" Model 1078 Dip Tube Sense
Vertical Outlet Only**

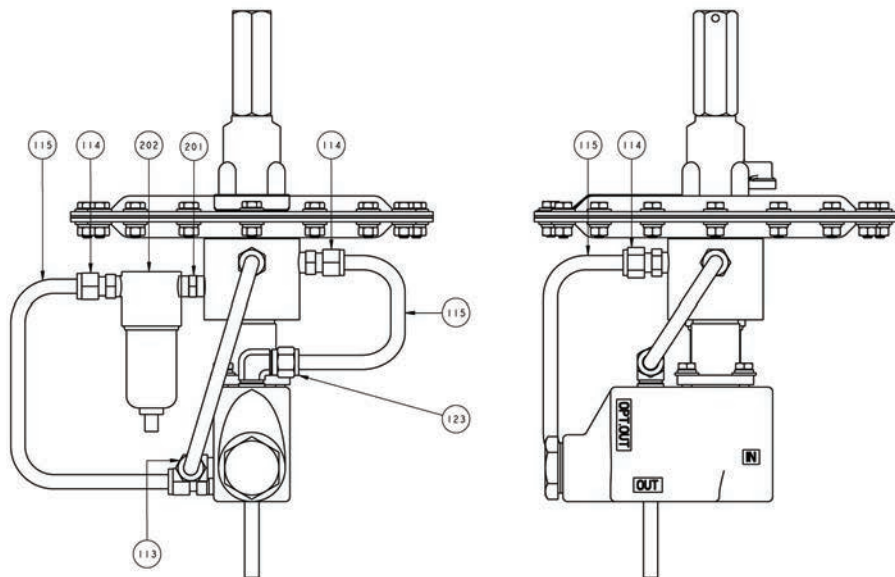

ITEM NO.	QUANTITY	PART NAME
1	1	Cap
5	1	Spring Bonnet
8	2	Gasket ‡
9	2	Diaphragm Case
11	16	Cap Screws
12	20	Lockwashers
15	16	Nuts
36	1	Mounting Plate
37	1	Pilot Mount
38	1	Pilot Body
41	32	Washers

ITEM NO.	QUANTITY	PART NAME
108	1	Main Body
113	1	Elbow Fitting
114	3	Tube Fittings
115	2	Tubings
116	1	Pipe Plug
117	1	Pipe Plug
118	1	Thermocouple Fitting
119	1	Name Plate
123	1	Dip Tube
201	1	Orifice Fitting
202	1	Filter Assy

‡ Typical Parts required for inspection and rebuild.

1" Model 1078 Internals

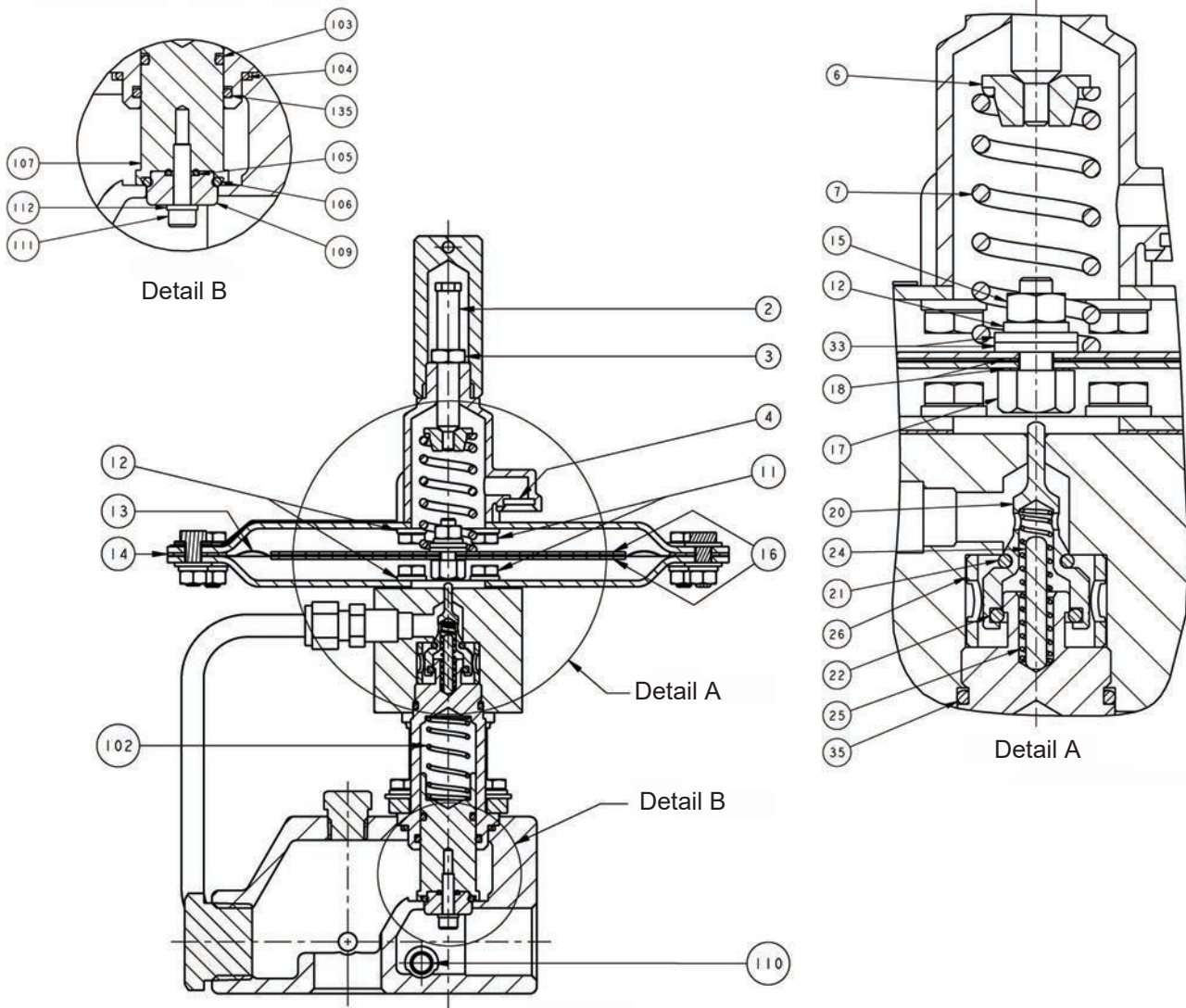

ITEM NO.	QUANTITY	PART NAME	ITEM	QUANTITY	PART NAME
2	1	Adjusting Screw	24	1	Guide Pin
3	1	Jam Nut	25	1	Return Spring
4	1	Vent Screen	26	1	Spacer
6	1	Spring Button	33	2	Washer
7	1	Pressure Spring	35	1	O-Ring ‡ (-120)
11	4	Cap Screws	102	1	Spring
12	4	Lockwashers	103	1	O-Ring ‡ (-116)
13	1	Sense Diaphragm ‡	104	1	O-Ring ‡ (-125)
14	1	Ring Gasket ‡	105	1	O-Ring ‡ (-010)
15	1	Nut	106	1	O-Ring ‡ (-115)
16	2	Support Plates	107	1	Piston
17	1	Center Bolt	109	1	Flow Plug
18	2	Bolt Gaskets ‡	110	1	Strainer
20	1	Spindle	111	1	Screw
21	1	O-Ring ‡ (-110)	112	1	Lockwasher
22	1	O-Ring ‡ (-112)	135	1	O-Ring ‡ (-119)

‡ Typical Parts required for inspection and rebuild.

1" Model 1078 with Tank & Supply Gauges

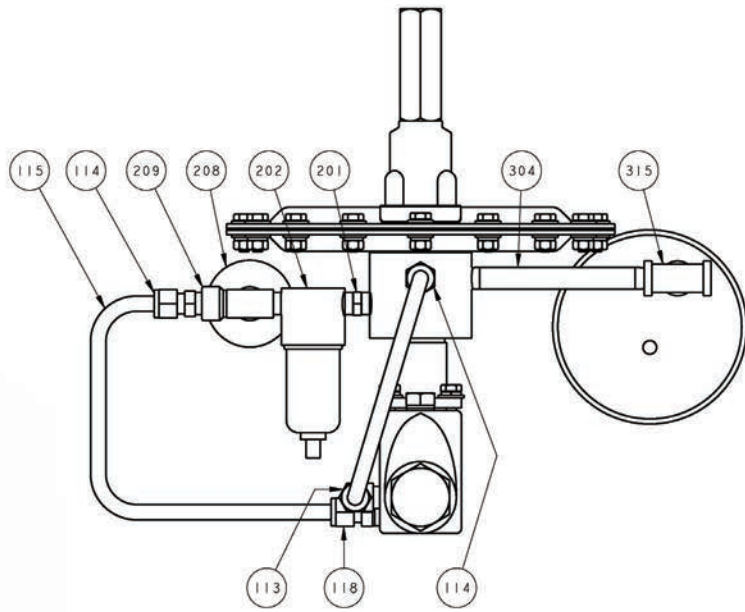

Remote Sense

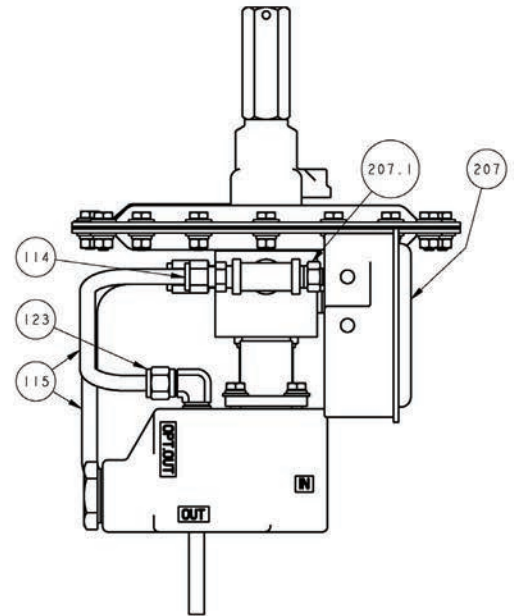

Dip Tube Sense

1" Model 1078 with Purge, Tank & Supply Gauges

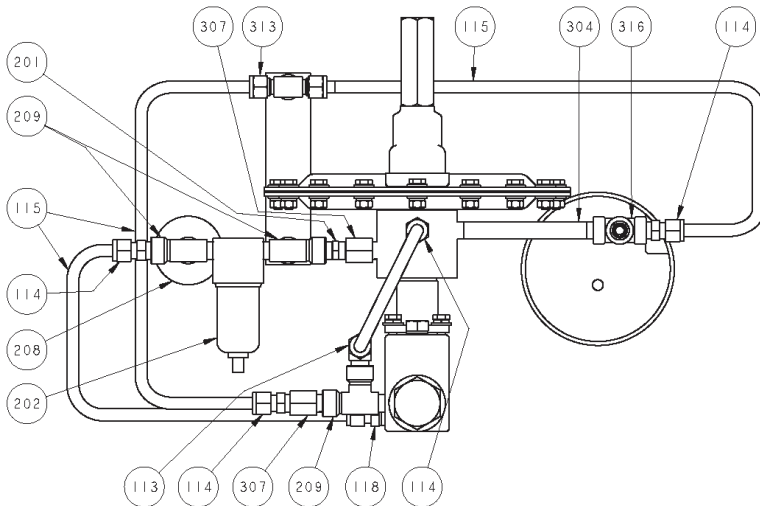

Remote Sense

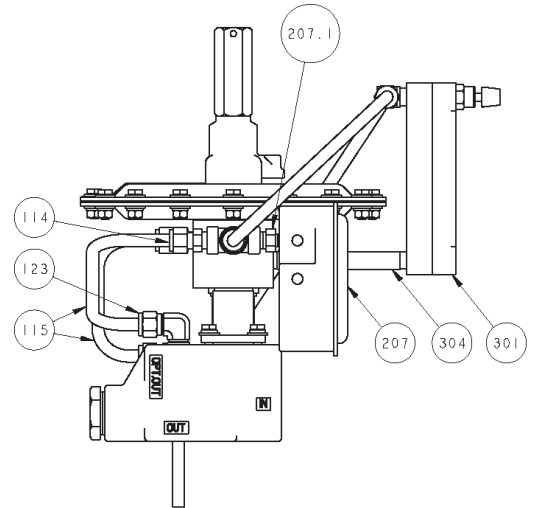

Dip Tube Sense

ITEM NO.	QUANTITY	PART NAME
113	1	Elbow Fitting
114	5	Tube Fittings
115	5	Tubings
118	1	Thermocouple Fitting
123	1	Dip Tube
201	1	Orifice Fitting
202	1	Filter Assy
207	1	Tank Gauge

ITEM NO.	QUANTITY	PART NAME
207.1	1	Reducing Nipple
208	1	Supply Gauge
209	2	Street Tee
301	1	Purge Meter
304	2	Nipples
307	2	Orifice Fittings
313	1	Branch Tee
316	1	FNPT Cross

1" Model 1078 with Check Valve, Tank & Supply Gauges

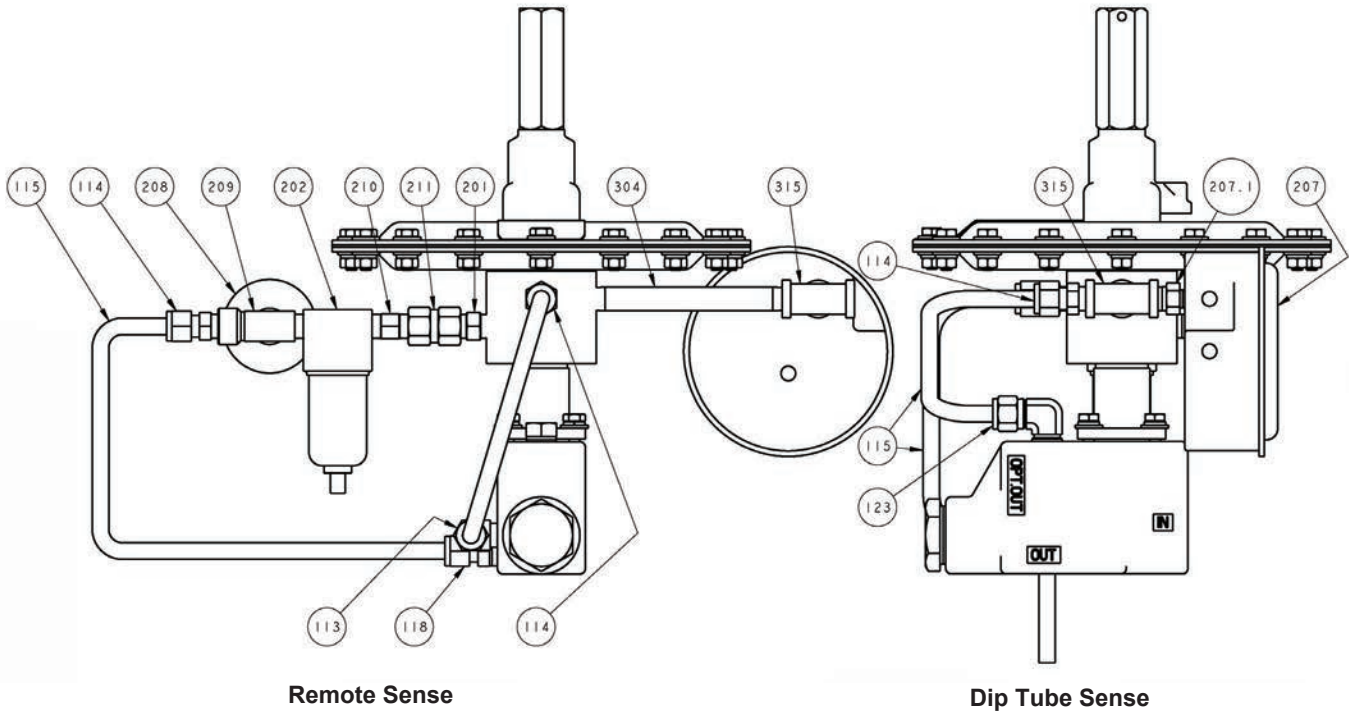

1" Model 1078 with Purge, Check Valve, Tank & Supply Gauges

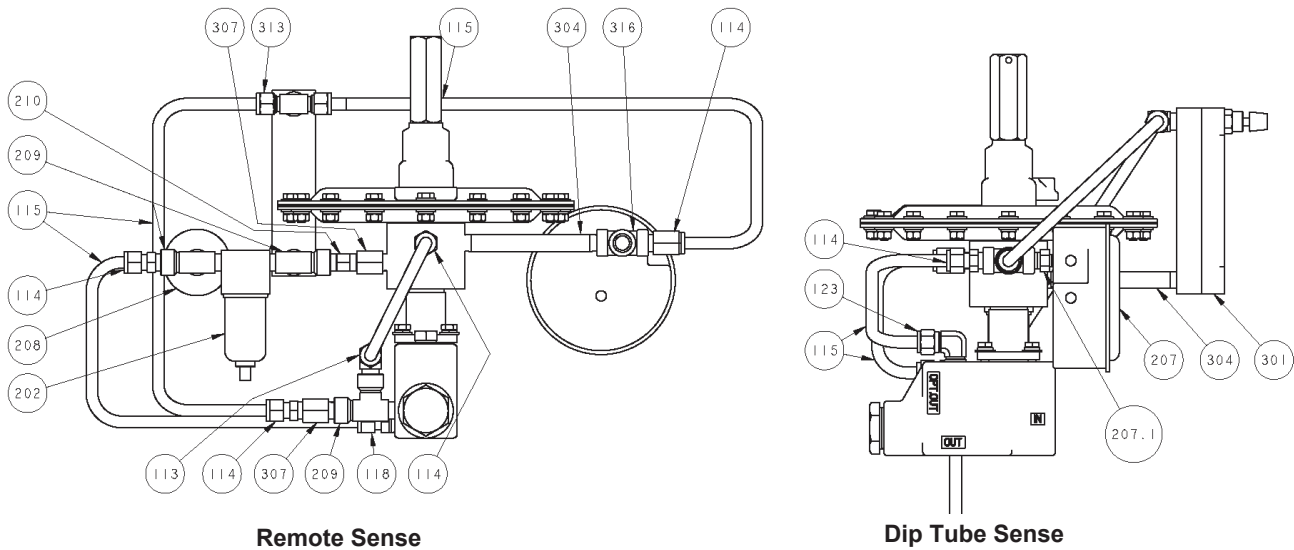

ITEM NO.	QUANTITY	PART NAME
113	1	Elbow Fitting
114	5	Tube Fittings
115	5	Tubings
118	1	Thermocouple Fitting
123	1	Dip Tube
201	1	Orifice Fitting
202	1	Filter Assy
207	1	Tank Gauge
201.1	1	Reducing Nipple
208	1	Supply Gauge

ITEM NO.	QUANTITY	PART NAME
209	2	Street Tees
210	1	Check Valve
211	1	Hex Coupling
301	1	Purge Meter
304	2	Nipples
307	2	Orifice Fittings
313	1	Branch Tee
315	2	FNPT Tee
316	1	FNPT Cross

**2" Model 1078 Remote Sense
Horizontal or Vertical Outlet**

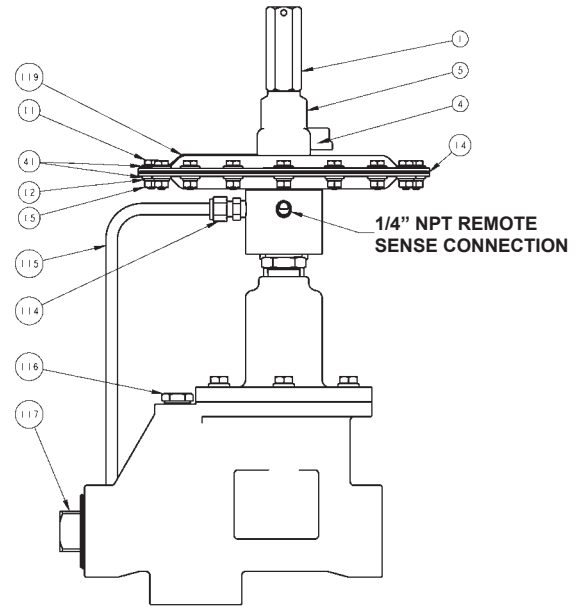
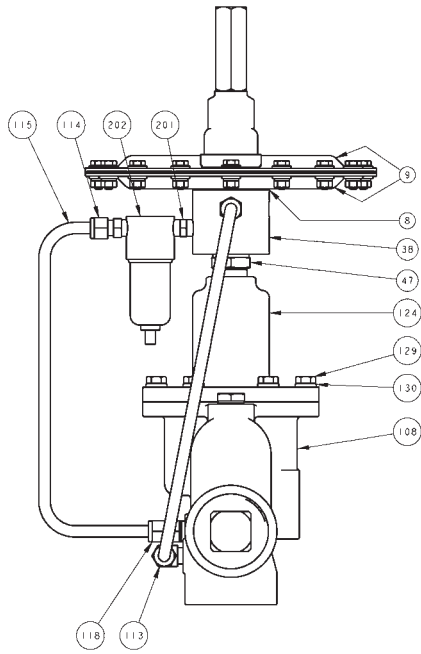

**2" Model 1078 Dip Tube Sense
Vertical Outlet Only**

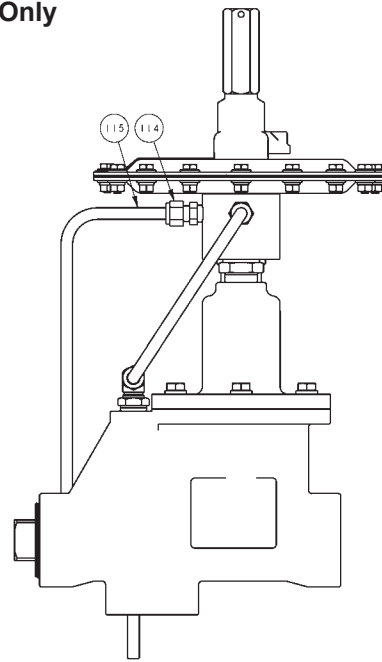
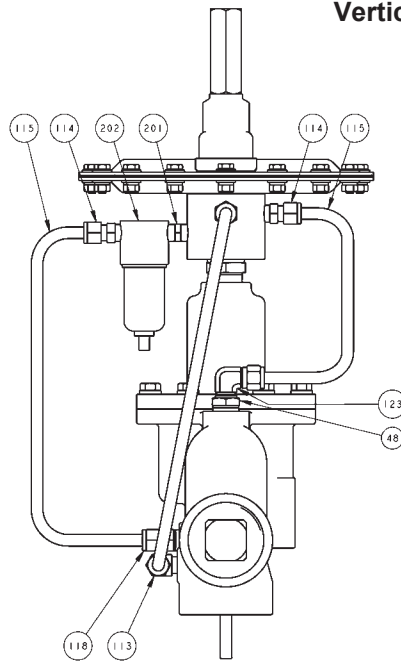

ITEM NO.	QUANTITY	PART NAME
1	1	Cap
4	1	Vent Screen
5	1	Spring Bonnet
8	1	Gasket ‡
9	2	Diaphragm Case
11	16	Cap Screws
12	20	Lockwashers
14	1	Ring Gasket ‡
15	16	Nuts
38	1	Pilot Body
41	32	Washers
47	1	Pilot Connector
48	1	Bushing
108	1	Main Body

ITEM NO.	QUANTITY	PART NAME
113	1	Elbow Fitting
114	3	Tube Fittings
115	2	Tubings
116	1	Pipe Plug
117	1	Pipe Plug
118	1	Thermocouple Fitting
119	1	Name Plate ‡
123	1	Dip Tube
124	1	Piston Housing
129	6	Cap Screws
130	6	Lock Washer
201	1	Orifice Fitting
202	1	Filter Assy

‡ Typical Parts required for inspection and rebuild.

2" Model 1078 Internals

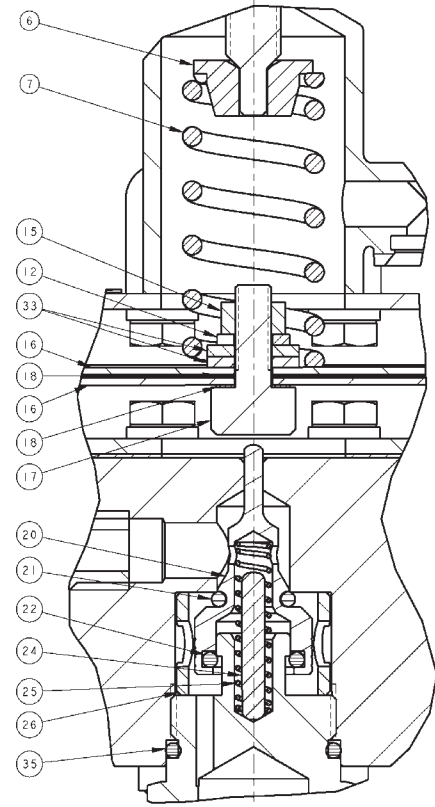
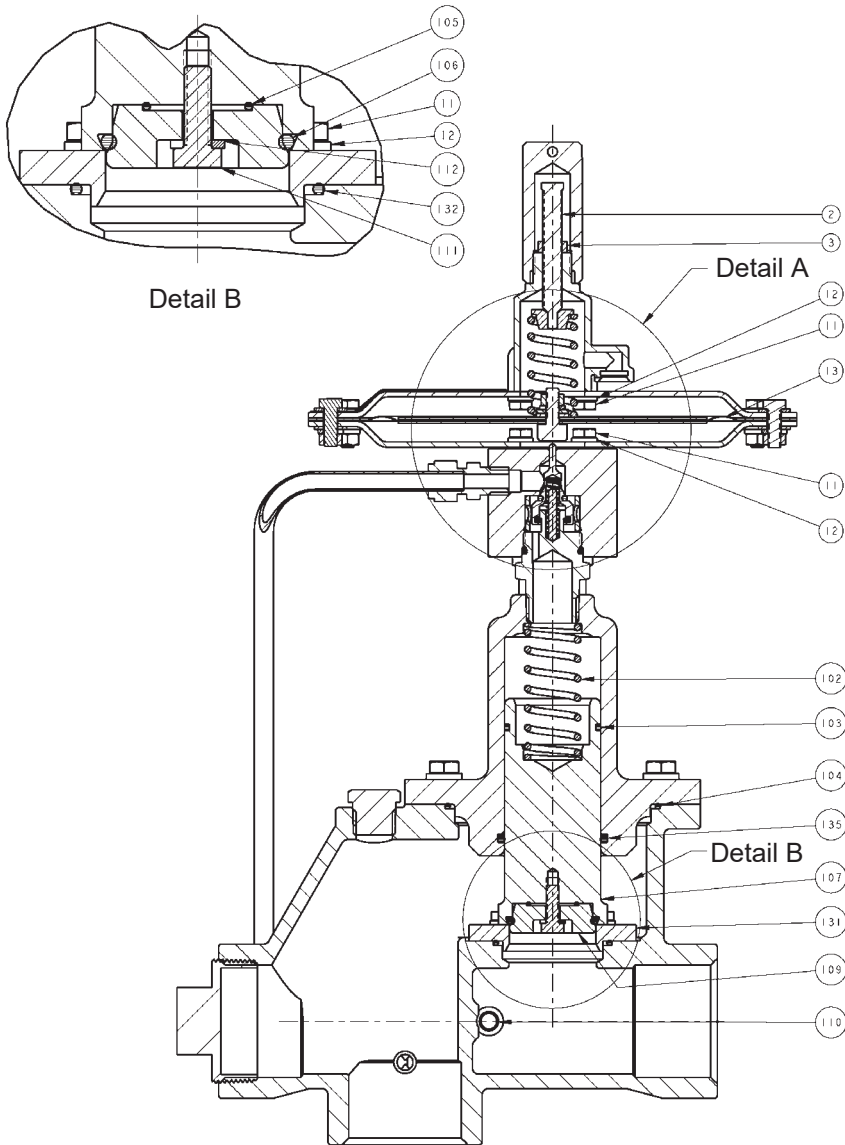

Detail A

ITEM NO.	QUANTITY	PART NAME
2	1	Adjusting Screw
3	1	Jam Nut
6	1	Spring Button
7	1	Pressure Spring
11	4	Cap Screws
12	4	Lockwashers
13	1	Sense Diaphragm ‡
15	1	Nut
16	2	Support Plates
17	1	Center Bolt
18	2	Bolt Gaskets ‡
20	1	Spindle
21	1	O-Ring ‡ (-110)
22	1	O-Ring ‡ (-112)
24	1	Guide Pin
25	1	Return Spring

ITEM	QUANTITY	PART NAME
26	1	Spacer
33	2	Washer
35	1	O-Ring ‡ (-120)
102	1	Spring
103	1	O-Ring ‡ (-131)
104	1	O-Ring ‡ (-155)
105	1	O-Ring ‡ (-020)
106	1	O-Ring ‡ (-223)
107	1	Piston
109	1	Flow Plug
111	1	Screw
112	1	Lockwasher
131	1	Seat Ring
132	1	O-Ring ‡ (-138)
135	1	O-Ring ‡ (-225)

‡ Typical Parts required for inspection and rebuild.

2" Model 1078 with Tank & Supply Gauges

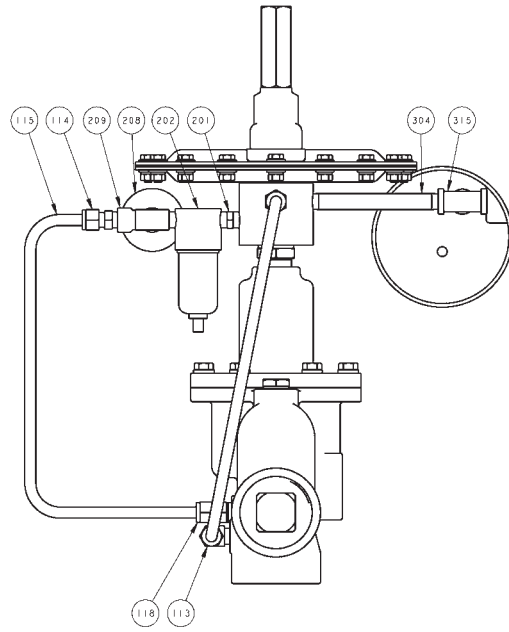

Remote Sense

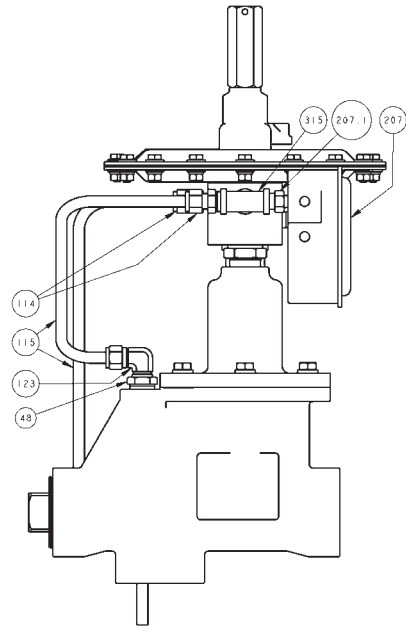

Dip Tube Sense

2" Model 1078 with Purge, Tank & Supply Gauges

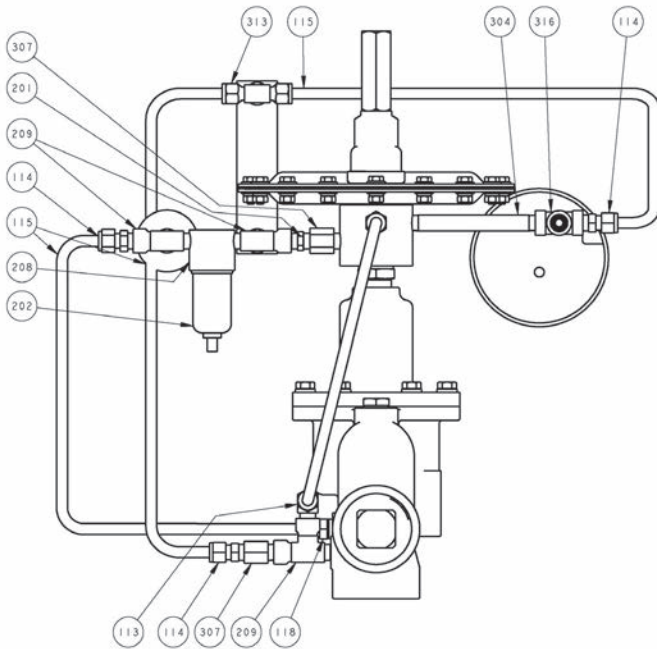

Remote Sense

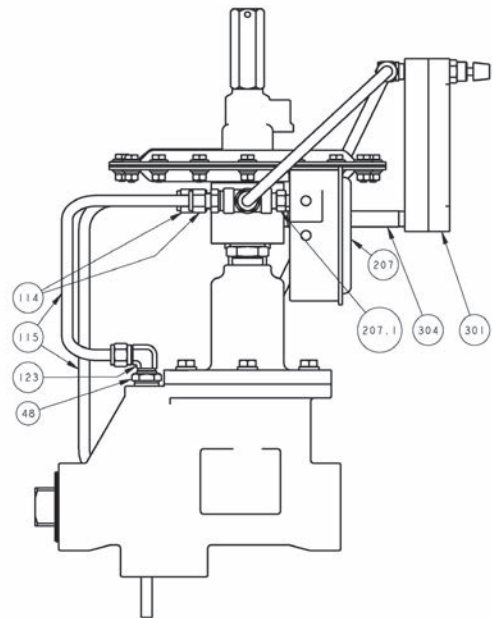

Dip Tube Sense

ITEM NO.	QUANTITY	PART NAME
48	1	Bushing
113	1	Elbow Fitting
114	5	Tube Fittings
115	5	Tubings
118	1	Thermocouple Fitting
123	1	Dip Tube
201	1	Orifice Fitting
202	1	Filter Assy
207	1	Tank Gauge

ITEM NO.	QUANTITY	PART NAME
207.1	1	Reducing Nipple
208	1	Supply Gauge
209	2	Street Tee
301	1	Purge Meter
304	2	Nipples
307	2	Orifice Fittings
313	1	Branch Tee
315	1	FNPT Tee
316	1	FNPT Cross

2" Model 1078 with Check Valve, Tank & Supply Gauges

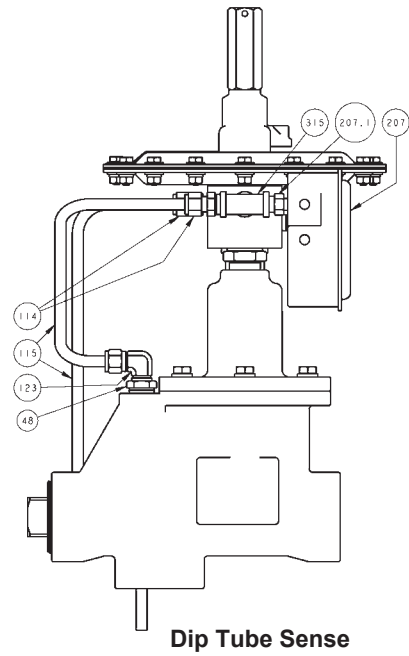
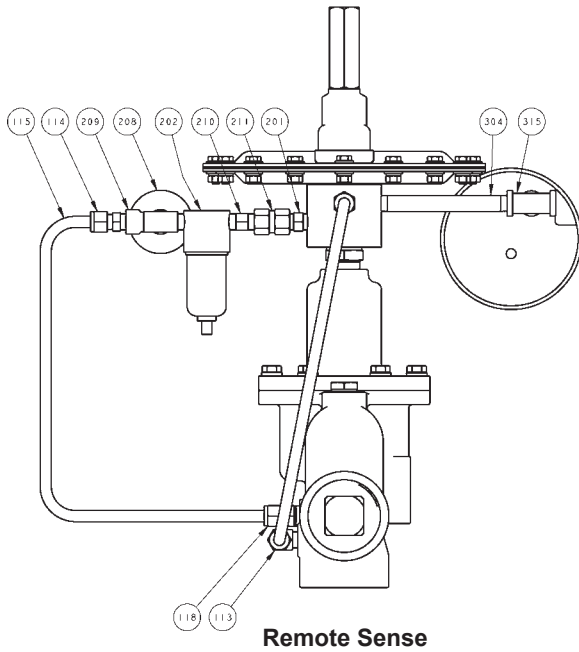

2" Model 1078 with Purge, Check Valve, Tank & Supply Gauges

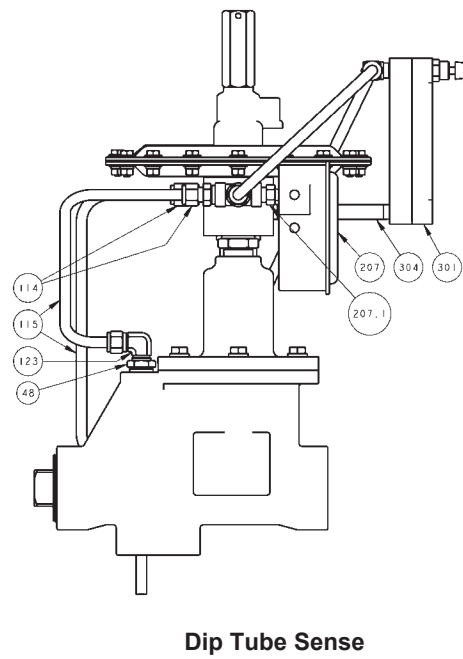
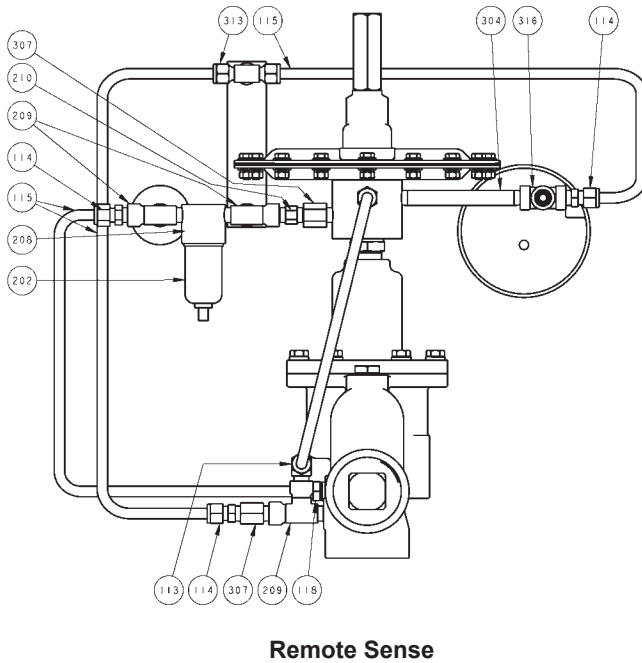

ITEM NO.	QUANTITY	PART NAME
48	1	Bushing
113	1	Elbow Fitting
114	5	Tube Fittings
115	5	Tubings
118	1	Thermocouple Fitting
123	1	Dip Tube
201	1	Orifice Fitting
202	1	Filter Assy
207	1	Tank Gauge
201.1	1	Reducing Nipple

ITEM NO.	QUANTITY	PART NAME
208	1	Supply Gauge
209	2	Street Tees
210	1	Check Valve
301	1	Purge Meter
304	2	Nipples
307	2	Orifice Fittings
313	1	Branch Tee
315	2	FNPT Tee
316	1	FNPT Cross

ATEX 2014/34/EU: Explosive Atmospheres and Cashco Inc. Products



Cashco, Inc. declares that the products listed in the table below has been found to comply with the Essential Health and Safety Requirements relating to the design and construction of products intended for use in potentially explosive atmospheres given in Annex II of the ATEX Directive 2014/34/EU. Compliance with the Essential Health and Safety Requirements has been assured by compliance with EN ISO 80079-36:2016 and EN ISO 80079-37:2016. The product will be marked as follows:

CE Ex II 2 G
Ex h IIB T6... T1 Gb
1000ATEXR1 X

The 'X' placed after the technical file number indicates that the product is subject to specific conditions of use as follows:

1. The maximum surface temperature depends entirely on the operating conditions and not the equipment itself. The combination of the maximum ambient and the maximum process medium temperature shall be used to determine the maximum surface temperature and corresponding temperature classification, considering the safety margins described prescribed in EN ISO 80079-36:2016, Clause 8.2. Additionally, the system designer and users must take precautions to prevent rapid system pressurization which may raise the surface temperature of system components and tubing due to adiabatic compression of the system gas. Furthermore, the Joule-Thomson effect may cause process gases to rise in temperature as they expand going through a regulator. This could raise the external surface temperature of the regulator body and the downstream piping creating a potential source of ignition. Whether the Joule-Thomson effect leads to heating or cooling of the process gas depends on the process gas and the inlet and outlet pressures. The system designer is responsible for determining whether the process gas temperature may raise under any operating conditions.
2. Where the process medium is a liquid or semi-solid material with a surface resistance in excess of 1GΩ, special precautions shall be taken to ensure the process does not generate electrostatic discharge.
3. Special consideration shall be made regarding the filtration of the process medium if there is a potential for the process medium to contain solid particles. Where particles are present, the process flow shall be <1m/s (<3.3 ft/s) in order to prevent friction between the process medium and internal surfaces.
4. Effective earthing (grounding) of the product shall be ensured during installation.
5. The valve body/housing shall be regularly cleaned to prevent build up of dust deposits.
6. Regulators must be ordered with the non-relieving option (instead of the self-relieving option) if the process gas they are to be used with is hazardous (flammable, toxic, etc.). The self-relieving option vents process gas through the regulator cap directly into the atmosphere while the non-relieving option does not. Using regulators with the self-relieving option in a flammable gas system could create an explosive atmosphere in the vicinity of the regulator.
7. Tied diaphragm regulators with outlet ranges greater than 7 barg (100 psig) should be preset to minimize the risk that improper operation might lead to an outboard leak and a potentially explosive atmosphere.
8. All equipment must only be fitted with manufacturer's original spare parts.
9. Ensure that only non-sparking tools are used, as per EN 1127-1, Annex A.

	PRODUCT
REGULATORS	31-B, 31-N
	1164, 1164(OPT-45)
	1171, 1171(OPT-45), 1171(CRYO)
	2171, 2171(OPT-45), 2171(CRYO), 3171
	1465, 3381, 3381(OPT-45), 3381(OPT-40)
	4381, 4381(OPT-37), 4381(CRYO), 4381(OPT-45), 5381
	MPRV-H, MPRV-L
	PBE, PBE-L, PBE-H
	CA-1, CA-2
	CA1, SA1, CA4, SA4, CA5, SA5
	DA2, DA4, DA5, DA6, DA8
	DA0, DA1, DAP, SAP
	SLR-1, SLR-2, PTR-1
	ALR-1, ULR-1, PGR-1
	BQ, BQ(OPT-45), BQ(CRYO)
	123, 123(CRYO), 123(OPT-45), 123(OPT-46G)
	123-1+6, 123-1+6(OPT-45), 123-1+6(OPT-46G), 123-1+6+S, 123-1+6+S(OPT-40)
	1000HP, 1000HP(OPT-37), 1000HP(OPT-45), 1000HP(OPT-45G), 1000HP(CRYO)
	1000HP-1+6, 1000HP-1+8, 1000LP, 1000LP(OPT-45), 1000LP(OPT-46G)
	6987
	8310HP, 8310HP-1+6, 8310HP-1+8, 8310LP, 8311HP, 8311LP
	345, 345(OPT-45)
	BA1/BL1, PA1/PL1
	C-BPV, C-PRV, C-CS
	D, D(CRYO), D(OPT-37), D(OPT-20), D(OPT-45)
	DL, DL(LCC), DL(OPT-45)
	BR, BR(CRYO)
	HP, HP(LCC), HP(OPT-45), HP(OPT46G), HP-1+6+S(OPT-40), HP-1+6+S
	P1, P2, P3, P4, P5, P7
	B2, B7
	POSR-1, POSR-2
5200P, 5300P	
135	
NW-PL, NW-SO	
CG-PILOT	
FG1	
CONTROL VALVES	RANGER, 987, PREMIER
	964, 521, 988, 988-MB, 989
	2296/2296HF
	SCV-30, SCV-S
	FL800/FL200
TANK BLANKETING	8700, 8910, 8920, 8930, 8940
	2100, 2199
	3100, 3200, 3300, 3400, 3500, 3600, 3700
	1078, 1088, 1100, 1049
	5100, 5200, 5400, 5500
	4100, 4200, 4300, 4400, 4500, 4600
MISC	764P/PD, 764-37, 764T



**Valve
& Automation**
Total Valve & Control Solutions®

JOHANNESBURG

Tel: 011 397 2833

DURBAN

Tel: 031 579 2593

South Africa:

0861 103 103

E-mail: sales@valve.co.za

www.valve.co.za



SCAN ME