



INDUSTRIAL REGULATORS

www.cashco.com
Innovative Solutions

Get Consistent Quality

By involving every employee in our ISO 9001:2015 Quality Assurance Program, you can count on the quality we provide you. We have coordinated our business systems, invested in state-of-the-art machine tools, and built an extensive component inventory so we can consistently provide cost-effective solutions and on-time delivery to meet your replacement or project requirements — regardless of size or complexity.

Make the Right Choice

“We simply make it right” by putting your needs first. The next time you specify control valves, regulators or vapor control emission systems, or you need a replacement fast...call the supplier that makes it right. Rely on Cashco for your single-source convenience. Great service, field-proven quality, and timely delivery makes Cashco the right choice.

Select Control Valves & Regulators

FOR SPECIALIZED OR UTILITY SERVICE

We manufacture a broad line of throttling rotary and linear control valves, pressure reducing regulators, and back pressure regulators in line sizes from 1/4 inch to 10 inches and Cv ranges from .002 to 4,406. Models are available to handle slurries, cryogenic service, and corrosive fluids; to withstand high temperatures and pressures; and to maximize the reduction of fugitive emissions. Contact Cashco for complete product information.





WE ARE CASHCO

The Strength Of Our Organization Is Our Employees

COMMITMENT. QUALITY. DEDICATION.

Cashco, Inc., is a manufacturing enterprise, centrally located within the United States. Our employees use hard work, commitment, and passion to define company goals that deliver world-class products at a fair price.

At Cashco, we continue to innovate our products until they are recognized as best in class within their respective industry. If the customer is not satisfied, we take it upon ourselves to make it right. Cashco employees are the bloodline of our company elevating products above industry standards for performance, dependability, and safety.

At Cashco, the strength of our organization is our employees.

TABLE OF CONTENTS

Pressure Reducing Regulators

Cashco		Model SLR-1	14
Model 1000HP	5	Model SLR-2	14
Model D/DL	5	Model P1	15
Model 1000LP	6	Model P2	15
Model POSR-1	6	Model P3	15
Model POSR-2	6	Model P4	16
Model 31-N	7	Model P5	16
Model 1465	7	Model P7	16
Model 3381	7		
Model 4381	8	Back Pressure Regulators	
Model MPRV-L	8	Cashco	
Model MPRV-H	8	Model BQ	17
Model PBE	8	Model BR	17
Model PBE-L	9	Model 123	18
Model PBE-H	9	Model 1171	18
Model HP	9	Model 1164	19
Model 8310LP/HP	10	Model 6987	19
Model 345	10	Model 2171	20
Model DA1	11	Model 8311HP/LP	20
Model DA2	11	Model CA-1 & CA-2	21
Model DA4	12	Model 31-B	21
Model DAP	12	Model DA-5	22
Model DAO	12	Model DA-6	22
Model PGR-1	13	Model DA-8	23
Model ULR-1	13	Model B2	23
Model PTR-1	13	Model B7	23
Model ALR-1	14		



At Cashco we have been creating innovative pressure control solutions to meet the needs of American industry since 1914. Today you'll find the Cashco name on an extensive line of self-contained regulators, control valves, and vapor control systems that are available globally according to PED, CE, ATEX, and CRN.

Cashco regulators, control valves, and vapor control systems are in use worldwide, covering a wide range of applications. We believe our quality is surpassed only by the service we provide to ensure you get the product you need — when you need it.

When you contact Cashco or our representatives, you will discover the care we take to help you specify the best valve for your application and the speed with which we handle your order — large or small.

If you don't find what you're looking for in the following pages, we will be glad to provide you with personal assistance and technical literature. Please call 785.472.4461 or email us at: sales@cashco.com. You may also review our entire product offering at www.cashco.com.

MODEL // 1000HP

The Model 1000HP is the most versatile, self-contained pressure reducing regulator available today. Its unique internal design and straight-through flow path isolate the diaphragm from fluid velocity effects and increase capacity and stability at both high or low-flow rates. Flow-to-open design and extended guiding allow pressure drops to 650 psig. It can be used in severe service and cryogenic applications that normal pressure reducing regulators cannot handle. Four body materials and nineteen trim material selections provide compatibility with many fluids — including saturated and superheated steam, industrial gases, fuel oils, compressed air, sour gas, chemical, and other process fluid services.



The Model 1000HP is a self-contained pressure reducing regulator.

Body sizes:

1/2", 3/4", 1", 1-1/4", 1-1/2", 2"

Maximum Cv:

1.35 to 22

Materials:

Body	DI, BRZ, CS, 316 SST
Spring chamber	DI, BRZ, CS, 316 SST
Trim	BR, 416 SST, 316 SST
Seat	Metal – SST
	Composition – Buna-N, EPR, TFE, F.C. Elastomer
Diaphragm	Phos. BRZ, 302 SST, Neoprene, F.C. Elastomer, EPDM

End connections:

NPT, BSP, Flanged, Extended Pipe Ends, flanges in ASME or DIN

Temperature range:

-325° F to +600° F, (-198° C to +315° C), (special construction to -425° F), (-232° C)

Pressures:

Inlet: up to 740 psig standard, (51 barg)
 Outlet: 10 to 300 psig, (0.7 - 20 barg)

Pressure drop:

Up to 650 psig, (44 barg)

Options:

Differential construction (single and double diaphragm), pharmaceutical/food industry and cryogenic construction, NACE service, numerous industry-specific options

MODEL // D/DL

The Model D Pressure Reducing Regulator is a time-proven product. For over 80 years, this inexpensive, ruggedly built regulator with piston-type, valve plug has been serving in medium-capacity, industrial applications — including service for steam, air, oil, water, and many chemicals and gases. Optional construction extends Model D capabilities to cryogenic, pharmaceutical, food, and NACE applications.

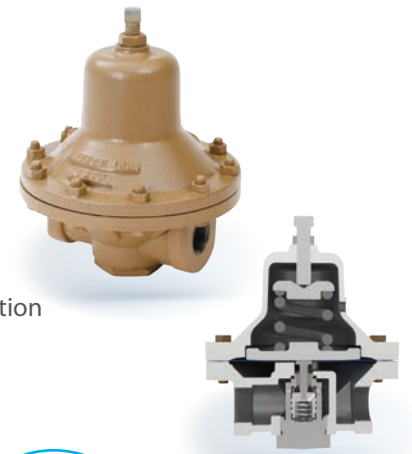

The Model D is an economical industrial-grade regulator.

Model D body size:

3/8", 1/2", 3/4", 1"

Model DL body size:

1-1/2", 2"

Model D maximum Cv:

1.8 to 4

Model DL maximum Cv:

7.0 to 10

Materials:

Body	CI, BRZ, CS, 316 SST
Spring chamber	CI, BRZ, CS, 316 SST
Trim	BRZ, 416 SST, 316 SST
Seat	Metal – BR, SST
	Composition – Buna-N, TFE, EPDM, F.C. Elastomer
Diaphragm	Phos. BRZ, 302 SST, Neoprene, F.C. Elastomer, EPDM

End connections:

NPT, BSP, Flanged, Extended Nipples, flanges in ASME or DIN

Temperature range:

-325° F to +400° F, (-198° C to +204° C)

Pressures:

Model D Inlet: up to 400 psig, (22 barg)
 Model DL Inlet: up to 300 psig, (20 barg)
 Model D Outlet: up to 250 psig, (17 barg)
 Model DL Outlet: up to 150 psig, (10 barg)

Pressure drop:

Up to 350 psid, (24 barg)

Options:

Handwheel and locking lever

MODEL // 1000LP

This 1000LP-Series Regulator has a larger diaphragm area than its 1000HP counterpart to handle lower operating pressures. But the 1000LP's basic construction, specifications, and superior rangeability mirrors the 1000HP regulator. The internal design isolates the diaphragm from fluid velocity effects and eliminates flow-induced instability at high and low-flow rates.

Body sizes:

1/2", 3/4", 1"

Maximum Cv:

3 to 9

Materials:

Body	CI, BRZ, CS, 316 SST
Spring chamber	CI, CS, 316 SST, BRZ
Trim	BR, 416 SST, 316 SST
Seat	Metal – SST Composition – Buna-N, TFE, F.C. Elastomer
Diaphragm	Phos. BRZ, 302 SST, Neoprene, F.C. Elastomer, EPDM

End connections:

NPT, BSP, Flanged, Extended Pipe Ends, flanges in ASME or DIN

Temperature range:

-20° F to +600° F, (-6° C to +315° C)

Pressures:

Inlet: up to 450 psig standard, (31 barg)
Outlet: 1 to 30 psig, (0.069 - 2barg)

Options:

Similar to options for 1000 HP



The Model 1000LP is a pressure reducing regulator with a large diaphragm area to handle lower operating pressures.

MODEL // POSR-1

The POSR-1 is a low-cost, pilot-operated pressure reducing steam regulator with a bellows seal design that eliminates sticking. Pilot and main valve trim are hardened 416 SST for long life. These regulators can maintain outlet pressure within +/- .5% and are commonly used in large steam heating installations and process applications with coolers, pasteurizers, sterilizers, vulcanizers, and other equipment. Available without the pilot as a pressure-loaded regulator.

Body sizes:

1/2", 3/4", 1"

Maximum Cv:

3.4 to 5.8

Materials:

Body	DI, CS
Seat	Metal – HDN 416 SST
Diaphragm	302 SST

End connections:

NPT

Temperature range:

Up to +450° F, (232° C)

Pressures:

Inlet: up to 300 psig, (20 barg)
Outlet: 5 to 150 psig, (0.34 -10 barg)

Pressure drop:

Up to 200 psid, (13 barg)

Options:

Pressure loaded main valve

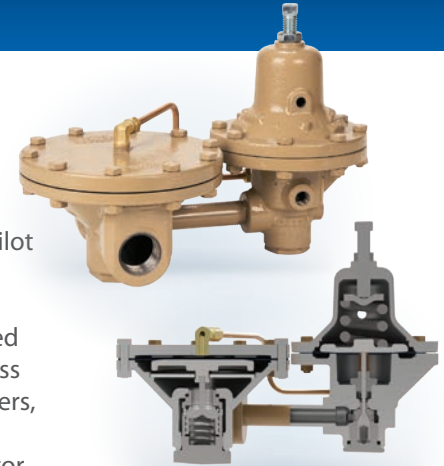

The Model POSR-1 is a low-cost pilot-operated steam regulator with bellows seals that eliminates sticking.

MODEL // POSR-2

The POSR-2 is a high-capacity version of the POSR-1. It utilizes a pressure-loaded piston design to eliminate the common problem of main valve diaphragm rupture. The POSR-1 and POSR-2 also eliminate common pilot valve sticking and provide high sensitivity and stability even on older or intermittently used steam systems.

The Model POSR-2 is a high-capacity, pilot-operated steam regulator with bellows seal that eliminates sticking.

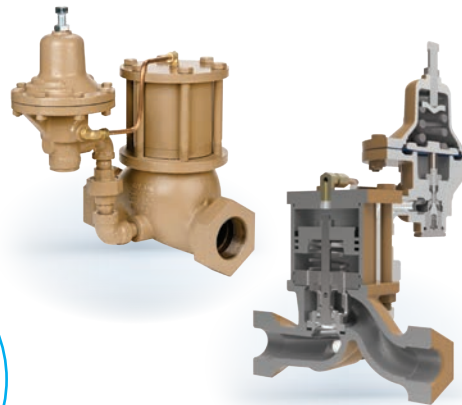

Body sizes:

1/2", 3/4", 1", 1-1/4", 1-1/2", 2", 3", 4"

Maximum Cv:

6.9 to 88

Materials:

Body	DI, CS
Seat	Metal – HDN 416 SST
Diaphragm	302 SST – pilot only

End connections:

NPT, Flanged, flanges in ASME or DIN

Temperature range:

Up to +450° F, (+232° C)

Pressures:

Inlet: up to 300 psig, (20 barg)
Outlet: 5 to 150 psig, (10 barg)

Pressure drop:

Up to 200 psid, (13 barg)

Options:

Handwheel

MODEL // 31-N

Model 31-N is designed for use in the process industry where low-pressure gas is controlled. Corrosion-resistant ST or SST construction negates gas diffusion effects. The 31-N is designed primarily for blanketing fluids that are volatile, corrosive, or lethal. No internal relief.



Body sizes:

1/2", 3/4", 1", 1-1/2", 2"

Maximum Cv:

0.5 to 3.9

Materials:

Body	CS, 316 SST
Spring chamber	CS, 316 SST
Trim	316L SST
Seat	Composition – Buna-N, Silicone, F.C. Elastomer
Diaphragm	Buna-N, F.C. Elastomer

End connections:

NPT, Flanges, Extended Nipples, flanges in ASME or DIN

Temperature range:

-30° F to +400° F, (-34° C to +204° C)

Pressures:

Inlet: up to 100 psig, (6.9 barg)
Outlet: 2" W.C. to 16" W.C., (5 mbarg to 40 mbarg)

Pressure drop:

Up to 100 psid, (6.9 bard)

Options:

Pharmaceutical and food industry construction

The Model 31-N is a regulator designed for up to 16" W.C. control.

MODEL // 1465

The Model 1465 is intended specifically for low-flow and high-pressure drop applications. It is frequently used to reduce pressure on a sample fluid to allow easier sampling/analysis.



Body size:

1/4"

Maximum Cv:

0.05 (0.109"orifice) to 0.19 (0.156"orifice)

Materials:

Body	316 SST
Spring chamber	BR, 316L SST
Trim	SST
Seat	Metal – Stellite
Diaphragm	302 SST, Neoprene, Elgiloy, FKM

End connections:

NPT

Temperature range:

-20° F to +400° F, (-28° C to +204° C)

Pressures:

Inlet: up to 5000 psig, (344 barg)
Outlet: 5 to 500 psig, (0.34 - 34 barg)

Pressure drop:

Up to 4700 psid, (324 bard)

Options:

NACE construction, high outlet pressure construction

The Model 1465 is a low-flow regulator for condensate analyzer letdown.

MODEL // 3381

The Model 3381 is designed to handle low to moderate flows. It is suitable for controlling a wide range of fluids, including industrial gases, air, oil, steam, and water. High-mass plug provides stability.

The Model 3381 is a bronze regulator for low-flow service.

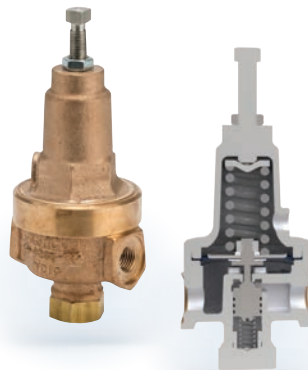

Body sizes:

1/4", 3/8"

Maximum Cv:

0.5

Materials:

Body	BRZ
Spring chamber	BRZ
Trim	BR
Seat	Metal – BR
Diaphragm	Composition – Buna-N, TFE Phos. BRZ, Neoprene, FKM

End connections:

NPT

Temperature range:

-325° F to +400° F, (-198° C to +204° C)

Pressures:

Inlet: up to 800 psig, (55 barg)
Outlet: 5 to 300 psig, (0.34 - 20 barg)

Options:

Cryogenic construction, dome loading, panel mounting, outlet pressure gauge

MODEL // 4381

The Model 4381 duplicates the strengths of the 3381 in SST. Its high-mass plug contributes to stability and it can handle industrial gases, air, oil, steam, water, and many chemicals.

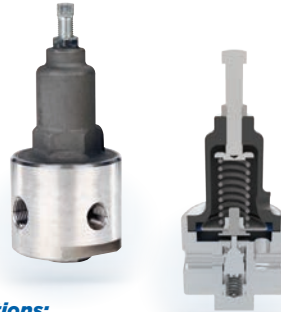

The Model 4381 is a SST-bodied regulator for low-flow service.

- Body sizes:**
1/4", 3/8", 1/2"
- Maximum Cv:**
0.5
- Materials:**
Body
Spring chamber
Trim
Seat

Diaphragm

- SST
BRZ, 316L SST
SST
Metal – 316 SST
Composition – TFE, EPDM
302 SST, TFE-coated
SST, Neoprene, EPDM

- End connections:**
NPT, Flanges, flanges in ASME or DIN
- Temperature range:**
-325° F to +400° F, (-198° C to + 204° C)
- Pressures:**
Inlet: up to 1500 psig, (103 barg)
Outlet: 2 to 500 psig, (140 mbarg to 34 barg)
- Options:**
Cryogenic construction, panel mounting, pharmaceutical/food industry construction, outlet pressure gauge

MODEL // MPRV-H

The Model MPRV-H is a compact, Brass body or SST body pressure regulator used to control outlet pressure up to 600 psig.

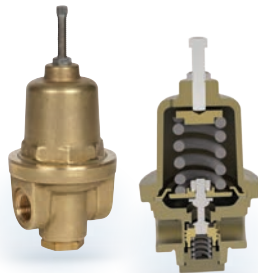

The Model MPRV-H is a compact pressure reducing regulator with a Max CV of 1.03.

- Body sizes:**
3/8", 1/2"
- Maximum Cv:**
1.03
- Materials:**
Body
Spring chamber
Trim
Seat
Diaphragm

- Bronze
316/316L SST
BR, SST
TFE or Buna-N
Metal – 302 SST, Composition-Gylon, Buna-N

- End connections:**
British Std Tapered Pipe Threads, FNTP
- Temperature range:**
-325 to +180°F, (-198° C to +82° C)
- Pressures:**
600 psig Max, (41 barg)

MODEL // MPRV-L

The Model MPRV-L is a compact, Brass body or SST body pressure reducing regulator used to control outlet pressure up to 600 psig.

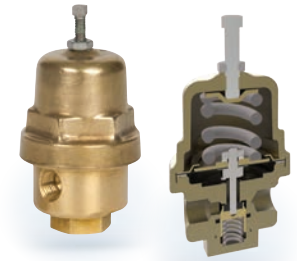

The Model MPRV-L is a compact regulator with a Max Cv of .48

- Body sizes:**
1/4", 3/8"
- Maximum Cv:**
.48
- Materials:**
Body
Spring chamber
Trim
Seat
Diaphragm
- Bronze - ASTM B283, C37700
316/316L SST - ASTM A479
Brass, SST
TFE or Buna-N
Metal – 302 SST, Composition-Gylon or Buna-N

- End connections:**
British Std Tapered Pipe Threads, FNTP
- Temperature range:**
-325 to +180°F, (-198° C to +204° C)
- Pressures:**
600 psig Max, (41 barg)

MODEL // PBE

The Model PBE has a compact body and functions in a dual role as a pressure building regulator and as an economizer relief regulator in one model. The pressure build feature controls the outlet pressure while the economizer feature operates to relieve any excess pressure in the system above set point from atmospheric to 600 psig.

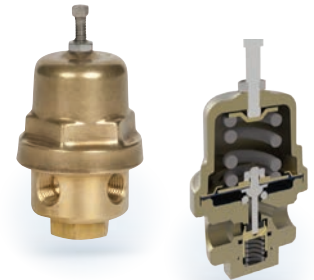

The Model PBE is a compact pressure build/economizer up to 1/4".

- Body sizes:**
1/4"
- Maximum Cv:**
.49
- Materials:**
Body
Spring chamber
Trim
Seat
Diaphragm
- Brass - ASTM B16, Alloy 360
Bronze - ASTM B283, C37700
BR
TFE
Gylon, 302 SST

- End connections:**
British Std Tapered Pipe threads, FNTP
- Temperature range:**
-325 to +150°F, (-198° C to +65° C)
- Pressures:**
600 psig Max, (41 barg)

MODEL // PBE-L

The Model PBE-L has a compact, forged body and functions in a dual role as a pressure building regulator and as an economizer relief regulator in one model. The pressure build feature controls the outlet pressure while the economizer feature operates to relieve any excess pressure in the system above set point from atmospheric to 600 psig.

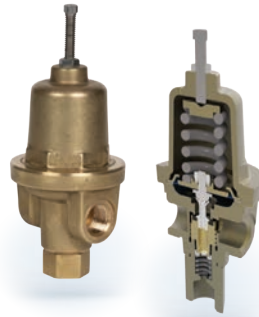

Body sizes:

1/2"

Maximum Cv:

1.21

Materials:

Body	Bronze
Spring chamber	Bronze
Trim	BR
Seat	TFE
Diaphragm	Metal – 302 SST, Composition or Gylon

End connections:

British Std Tapered Pipe Threads, FNPT

Temperature range:

-325 to +150°F,
(-198° C to +65° C)

Pressures:

600 psig Max,
(41 barg)

The Model PBE-L is a compact pressure build/economic regulator.

MODEL // PBE-H

The Model PBE has a compact body and functions in a dual role as a pressure building regulator and as an economizer relief regulator in one model. The pressure build feature controls the outlet pressure while the economizer feature operates to relieve any excess pressure in the system above set point from atmospheric to 250 psig.

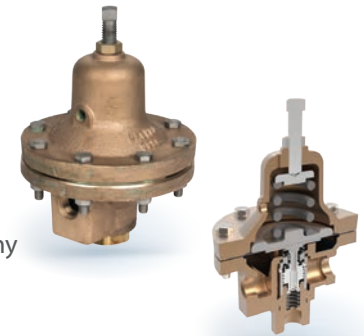

Body sizes:

1/2"

Maximum Cv:

1.80

Materials:

Body	Bronze - ASTM B62 C83600
Spring chamber	Bronze - ASTM B62 C83600
Trim	Br
Seat	TFE
Diaphragm	Phos. Bronze, 302 SST, or Gylon

End connections:

British Std Tapered Pipe Threads, FNPT

Temperature range:

-325 to +150°F,
(-198° C to +65° C)

Pressures:

400 psig Max,
(27 barg)

The Model PBE-H is a pressure build/economizer with Max CV up to 1.80.

MODEL // HP

The HP is a heavy-duty high-pressure regulator designed to control downstream pressure between 10 and 750 psig with inlet pressure as high as 3000 psig. Composition seat provides bubble-tight shutoff. Metal seating is available and metal seating surfaces can be stellite. This regulator is not designed to be used in steam applications.



The Model HP is a high-pressure regulator, the industry standard for differential service on seal oil systems.

Body sizes:

1/2", 3/4", 1", 1 1/2"

Maximum Cv:

4.39

Materials:

Body	CS, SST, Mn BRZ
Spring chamber	CS, SST, Mn BRZ
Trim	316 SST
Seat	Metal - 316 SST
	Composition-TFE or Nylon
Diaphragm	TFE coated SST, SST or Neoprene

End connections:

NPT, Flanged, BSP, Extended Pipe Ends, flanges in ASME or DIN

Temperature range:

-20° F to +600° F, (-201° C to +315° C)

Pressures:

Inlet: up to 3000 psig, (206 barg)
Outlet: 10 to 750 psig, (4 to 51 barg)

Options:

NACE Construction, Oxygen cleaned, Differential Construction

MODEL // 8310LP/8310HP

The Model 8310LP and the Model 8310HP are some of the highest-capacity pressure reducing regulators we manufacture. Their balanced plug design and double-port construction yields outstanding performance even at very low pressure drops. Diaphragms are isolated from fluid velocity effects. Applications include a wide variety of fluids.

Body sizes:

1-1/2", 2", 2-1/2", 3", 4"

Maximum Cv:

Up to 100

Materials:

Body	CI, CS
Spring chamber	DI, CS
Trim	SST
Seat	TFE, Rulon – 316 SST, Stellite
Diaphragm	302 SST, Neoprene, F.C. Elastomer

End connections:

1-1/2", 2"	– NPT, CI or CS
All sizes	– 125#, 250# flange, CI
All sizes	– 150#, 300# flange, CS

Temperature range:

-20° F to +450° F, (-29° C to +232° C)

Pressures:

HP – Inlet:	up to 650 psig, (44 barg) /
LP – Inlet:	up to 200 psig, (13 barg)
HP – Outlet:	10 to 200 psig, (0.69 to 13 barg) /
LP – Outlet:	1 to 30 psig, (0.07 to 2 barg)

Pressure drop:

HP – up to	450 psid, (31 bard) /
LP – up to	200 psid, (13 bard)

Options:

Differential service construction

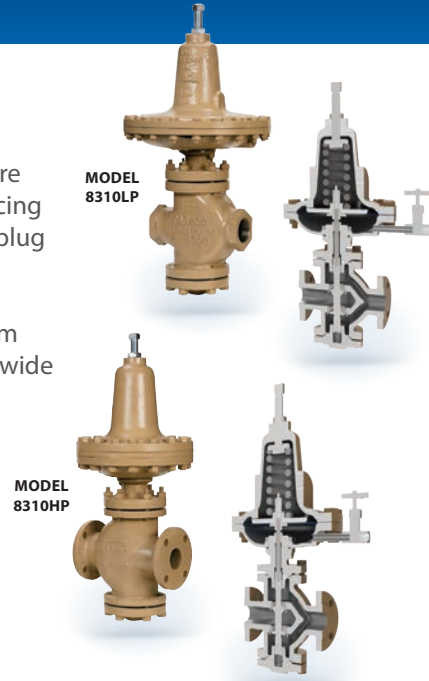

Models 8310LP/8310HP are self-contained high-capacity regulators with double-seat design ideal for remote installation.

MODEL // 345

The Model 345 utilizes a piston design to handle high pressures. With optional nylon or TFE seats, it can control downstream pressures between 50 and 3000 psig with inlet pressures as high as 4000 psig. A metal-seated version with an unbalanced trim design is also available. The Model 345 is used primarily as a first-stage letdown valve on high-pressure applications. It is not designed to be used in steam applications.

Body sizes:

1/2", 3/4", 1"

Maximum Cv:

Up to 1.8

Materials:

Body	Alum. BRZ, SST
Spring chamber	BRZ
Trim	316 SST
Seat	Metal – 316 SST, Stellite Composition – TFE, Nylon

End connections:

NPT, 300#, 600#, 900#, 1500# Flanges With SST Body

Temperature range:

Up to +400° F, (204° C)

Pressures:

Inlet:	up to 4000 psig, (275 barg)
Outlet:	50 to 3000 psig, (4 to 206 barg)

Pressure drop:

Up to 3000 psid, (206 bard)

Options:

Weld-on flanges



The Model 345 is a heavy-duty high-pressure regulator commonly found in hydraulic or gaseous service.

// PRESSURE REDUCING REGULATORS

Cashco has been a technological pioneer in the regulator industry since 1914. The regulators are designed to perform and built to last with the highest Cv and regulation accuracy available per valve size. They also offer the highest rangeability of any regulator in the industry.

Cashco regulators cover a wide range of compatible fluid applications including: water, steam, all industrial gases, acids, cryogenic fluids,

ultra-high purity fluids, corrosives, and high viscosity fluids.

In addition, we manufacture a comprehensive line of control valves and regulators for all your process requirements. Our sales consultants can help you specify the appropriate product for your applications at: sales@cashco.com.

MODEL // DA1

The DA1 is an excellent pressure reducing regulator for all fluid types. Whether it is GOX or a viscous fluid, the Model DA1 is able to provide constant and accurate control through the necessary range of flow of your application. The regulator features a high flow design with balanced trim as a standard. The balanced trim allows rangeability up to 1000:1 for varying flows with very little change in set pressure. Due to the high capacities these regulators provide, it is now possible to install regulators where control valves were once needed. This allows additional savings since controllers, positioners, and auxiliary air supply are no longer needed.

The Model DA1 is a high capacity pressure reducing regulator.

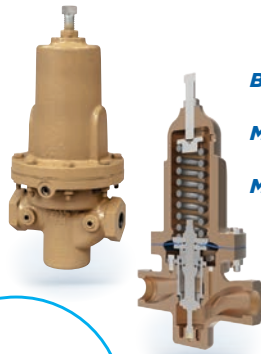

Body sizes:

1/2", 3/4", 1", 1-1/4", 1-1/2", 2", 2-1/2", 3", 4"

Maximum Cv:

198

Materials:

Body BRZ, DI, CS, HC, Duplex SST, 316 SST
Spring chamber BRZ, DI, CS, Duplex SST, 316 SST
Trim 17-PH SST, 316L SST, Monel
Seat PolyAll, V-TFE, GF-TFE, C+TFE, NBR, BC, FKM
Diaphragm Composition – BC, EPR, FKM, FK, NBR, FKM + TFE, Elast. TFE
 Metal – Be-Cu

End connections:

NPT, 125#-250#, 150#-600# Integral Flanged, PN16, PN25, PN40 DIN Flanged, Extended Pipe Nipples, Tube End Construction or BSP

Temperature range:

-425° to +400° F, (-253° C to +204° C)

Inlet Pressure:

10 - 1480 psig, (0.69 - 102 barg)

Outlet Pressure:

1 - 450 psig, (0.07 - 31 barg)

Options:

NACE, Cleaned for O2 Service, Cleaned for Chlorine Service

MODEL // DA2

The DA2 is a positive bias differential pressure reducing regulator for all fluid types. Much like the DA1, the ability to allow varying flows with little change in set pressure makes this an ideal regulator for high accuracy applications.

The Model DA2 is a positive bias differential pressure reducing regulator.



Body sizes:

1/2", 3/4", 1", 1-1/4", 1-1/2", 2", 3", 4"

Maximum Cv:

196

Materials:

Body BRZ, DI, CS, 316 SST
Spring chamber BRZ, DI, CS, 316 SST
Trim 17-PH SST, 316L SST, Monel
Seat PolyAll, V-TFE, GF-TFE, C+TFE, Buna-N, BC
Diaphragm Composition – BC, EPR, FKM, FK, NBR, FKM + TFE, Elast. TFE, Metal – Be-Cu

End connections:

NPT, 125#-250#, 150#-600# Integral Flanged, PN16, PN25, PN40 DIN Flanged, Extended Pipe Nipples, Tube End Construction or BSP

Temperature range:

-425° to +400° F, (-253° C to + 204° C)

Inlet Pressure:

10 - 3705 psig, (0.69 - 255 barg)

Options:

Cleaned for O2 Service, Cleaned for Chlorine Service

MODEL // DA4

The DA4 is a dome loaded, high capacity reducing regulator. Much like the DA1, the ability to allow varying flows with little change in set pressure makes this an ideal regulator for high accuracy applications. (The DA4 and the DA6 are ideal solutions for automating your pressure control systems.)

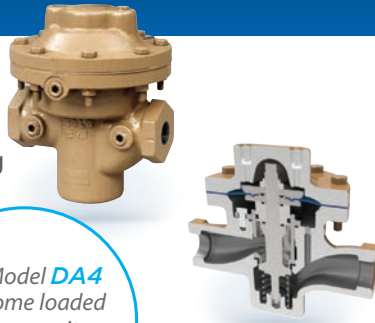

The Model DA4 is a dome loaded high capacity reducing regulator.

Body sizes:

1/2", 3/4", 1", 1-1/4", 1-1/2", 2", 2-1/2", 3", 4"

Maximum Cv:

198

Materials:

Body	BRZ, DI, CS, Duplex SST, 316 SST
Cover Dome	BRZ, DI, CS, Duplex SST, 316 SST
Trim	17-PH SST, 316L SST, Monel
Seat	PolyAll, V-TFE, GF-TFE, C+TFE, BC, NBR, FKM
Diaphragm	Composition – BC, EPR, FKM, FK, NBR, FKM + TFE, Elast. TFE, Metal – Be-Cu

Temperature range:

-425° to +400° F,
(-253° C to +204° C)

Inlet Pressure:

10 - 3705 psig,
(0.69 - 255 barg)

Outlet Pressure:

2.0" W.C. - 1500 psig,
(0.04 - 103 barg)

Options:

NACE, Cleaned for O2 Service,
Cleaned for Chlorine Service

End connections:

NPT, 125#-250#, 150#-600# Integral
Flanged, PN16, PN25, PN40 DIN Flanged, Extended
Pipe Nipples, Tube End Construction or BSP

MODEL // DAP

The DAP is a pressure loaded pressure reducing regulator for all fluid types. Much like the DAO, the ability to allow varying flows with little change in set pressure makes this an ideal regulator for high accuracy applications. The difference is the larger piston design, which allows for higher outlet pressures with lower pressure drops across the valve.

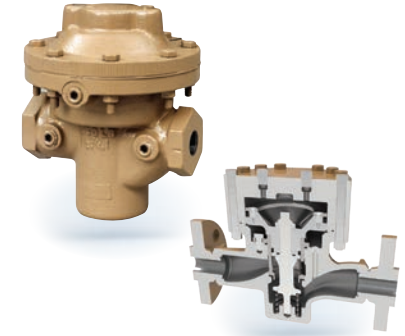

The Model DAP is a large piston/pilot operated gaseous pressure reducing regulator.

Body sizes:

1/2", 3/4", 1", 1-1/2", 2"

Maximum Cv:

50

Materials:

Body	SST
Cover Dome	SST
Trim	17-PH SST, 316L SST
Seat	V-TFE, PA, C-TFE

End connections:

NPT, 150#, 300#, 600#, Integral Flanged,
PN16, PN25, PN40 DIN, Flanged, BSP

Temperature range:

-20° to +400° F, (-29° C to +204° C)

Inlet Pressure:

50 - 3600 psig, (4 - 248 barg)

Outlet Pressure:

1225 psig, (84 barg)

MODEL // DAO

The DAO is a pilot-operated steam reducing regulator with a piston design. The internal pressure balanced plug/piston provides high flow capacity and moderate pressure drop capability. Much like the DAP, the ability to allow varying flows with little change in set pressure makes this an ideal regulator for high accuracy applications. Apply in steam service applications only.

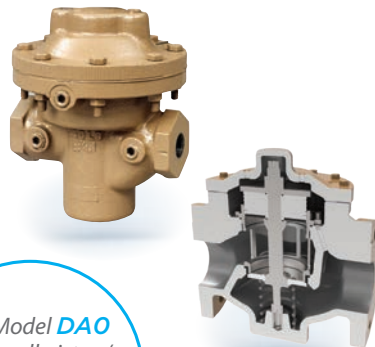

The Model DAO is a small piston/pilot operated steam pressure reducing regulator.

Body sizes:

1/2", 3/4", 1", 1-1/4", 1-1/2", 2", 2-1/2", 3", 4"

Maximum Cv:

220

Materials:

Body	DI, CS
Cover Dome	DI, CS
Trim	17-PH SST
Seat	GF-TFE

End connections:

NPT, 125#-250#, 150#-300#
Integral Flanged

Temperature range:

+100 F to +406° F, (+38° C to +208° C)

Inlet Pressure:

35 - 400 psig, (2.4 - 27 barg)

Outlet Pressure:

2 - 215 psig, (0.13 - 14 barg)

MODEL // PGR-1

Model PGR-1 is high performance, pressure loaded diaphragm-type, flow-to-open pressure reducing regulator. Design includes an internal pressure balancing piston-cylinder that provides high flow capacity. The internal trim design allows the same basic unit to cover a broad range of pressure settings. Performance meets or exceeds that of competitive pressure loaded or pilot-operated designs. The PGR-1 regulator is applied primarily in clean natural gaseous service and fuel gas - sweet or sour.



The Model PGR-1 is a precise pressure reducing regulator.

Body sizes:
1", 1-1/2", 2", 3", 4"

Maximum Cv:
198

Body/Cover Dome Materials:
DI/DI, CS/CS, SST/SST
DI = Ductile Iron
CS = Carbon Steel
SST = Stainless Steel

End connections:
ASME Flanged, NPT

Temperature range:
-70° to +250°F,
(-56° C to +121° C)

Inlet Pressure:
10 – 400 psig

Outlet Pressure:
2.0" W.C. – 200 psig

MODEL // ULR-1

Model ULR-1 is high performance, pressure loaded diaphragm-type, flow-to-open pressure reducing regulator. Design includes an internal pressure balancing piston-cylinder that provides high flow capacity and high pressure drop capability. The internal trim design allows the same basic unit to cover a broad range of pressure settings. Performance meets or exceeds that of competitive pressure loaded or pilot-operated designs. A back pressure regulator or "unloader" is piped to the top of the dome and is "set" to control the outlet pressure of the pressure reducing regulator.



The Model ULR-1 is an economical, high capacity, precision regulator.

Body sizes:
1/2", 3/4", 1", 1-1/4", 1-1/2", 2", 2-1/2", 3", 4"

Maximum Cv:
198

Body/Cover Dome Materials
DI/DI, BRZ/BRZ, CS/DI, BRZ/DI, CS/CS,
SST/SST, SST/DI, SST/CS
DI = Ductile Iron
SST = Stainless Steel
BRZ = Bronze
CS = Carbon Steel

End connections:
Standard: Female NPT
ASME Flanged: 125#, 150#,
250#, 300#, 600#
DIN Flanged: PN16, PN25,
PN40

Temperature range:
-50° to +400°F,
(-45° C to +204° C)

Max Operating Pressure:
475 psig, (32 barg)

MODEL // PTR-1

Model PTR-1 is high performance, pressure loaded diaphragm-type, flow-to-open pressure reducing regulator. Design includes an internal pressure balancing piston-cylinder that provides high flow capacity and high pressure drop capability. Performance meets or exceeds that of competitive pressure loaded or pilot-operated designs. A back pressure regulator or "unloader" is piped to the top of the dome and is "set" to control the outlet pressure of the pressure reducing regulator. In addition, a low temperature probe (pneumatic controller) with an integral, rigid insertion bulb and invar rod is installed up-stream of the Model PTR-1. When the exposed outer sheath senses a change in the process temperature below the minimum temperature set point of the probe, it vents loading pressure from the dome of the regulator and allows it to close.

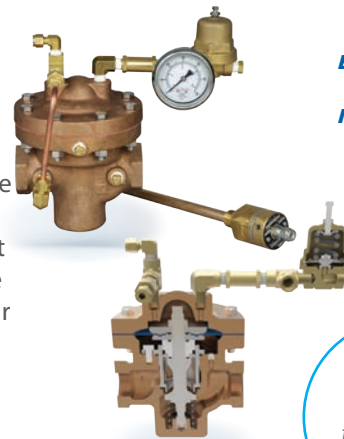

The Model PTR-1 is a precise temperature control regulator.

Body sizes:
1/2", 3/4", 1", 1-1/4", 1-1/2", 2", 2-1/2", 3", 4"

Maximum Cv:
198

Body/Cover Dome Materials
BRZ/BRZ SST/SST
BRZ = Bronze
SST = Stainless Steel

End connections:
Standard: Female NPT
ASME Flanged: 150#, 300#, 600#
DIN Flanged: PN16, PN25, PN40

Temperature range:
-325° to +400°F,
(-198° C to +204° C)

Max Operating Pressure:
475 psig, (32 barg)

MODEL // ALR-1

Model ALR-1 is high performance, pressure loaded diaphragm-type, flow-to-open pressure reducing regulator. Design includes an internal pressure balancing piston-cylinder that provides high flow capacity and high pressure drop capability. The internal trim design allows the same basic unit to cover a broad range of pressure settings. Performance meets or exceeds that of competitive pressure loaded or pilot-operated designs. A back pressure regulator or "unloader" is used to maintain outlet pressure through an auxiliary gas supply.



The Model ALR uses auxiliary gas supply to load the dome.

Body sizes:

1/2", 3/4", 1", 1-1/4", 1-1/2", 2", 2-1/2", 3", 4"

Maximum Cv:

198

Body/Cover Dome Materials

DI/DI, BRZ/BRZ, CS/DI, BRZ/DI, CS/CS, SST/SST, SST/DI, SST/CS

DI = Ductile Iron
SST = Stainless Steel
BRZ = Bronze
CS = Carbon Steel

End connections:

Standard: Female NPT
ASME Flanged: 125#, 150#, 250#, 300#, 600#
DIN Flanged: PN16, PN25, PN40

Temperature range:

-50° to +400°F,
(-45° C to +204° C)

Max Operating Pressure:

475 psig, (32 barg)

MODEL // SLR-1

Model SLR-1 is high performance, self-relieving and reducing regulator. Design includes an internal pressure balancing piston-cylinder that provides high flow capacity and high pressure drop capability. The internal trim design allows the same basic unit to cover a broad range of pressure settings. Performance meets or exceeds that of competitive pressure loaded or pilot-operated designs.

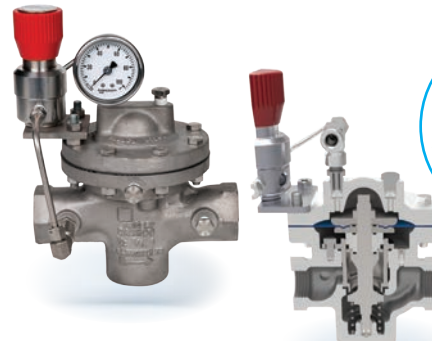

The Model SLR is a high performance, self relieving, pressure reducing regulator.

Body sizes:

1/2", 3/4", 1", 1-1/4", 1-1/2", 2", 2-1/2", 3", 4"

Maximum Cv:

198

Body/Cover Dome Materials

DI/DI, BRZ/BRZ, CS/DI, BRZ/DI, CS/CS, SST/SST, SST/DI, SST/CS

DI = Ductile Iron
SST = Stainless Steel
BRZ = Bronze
CS = Carbon Steel

End connections:

Standard: Female NPT
ASME Flanged: 125#, 150#, 250#, 300#, 600#; DIN Flanged: PN16, PN25, PN40

Temperature range:

-50° to +400°F,
(-45° C to +204° C)

Max Operating Pressure:

750 psig, (51 barg)

MODEL // SLR-2

Model SLR-2 is high performance, pressure loaded diaphragm-type, flow-to-open, non-relieving pressure reducing regulator. Design includes an internal pressure balancing piston-cylinder that provides high flow capacity and high pressure drop capability. Performance meets or exceeds that of competitive pressure loaded or pilot-operated designs. A non-relieving pressure regulator "loader" is bracket mounted to the top of the dome. The set point of the loader controls the upstream supply pressure into the dome to maintain the desired downstream pressure of the SLR-2. Pressure in the dome will constantly bleed out through a filter and check valve which is piped back into the outlet of the body of the pressure reducing regulator.

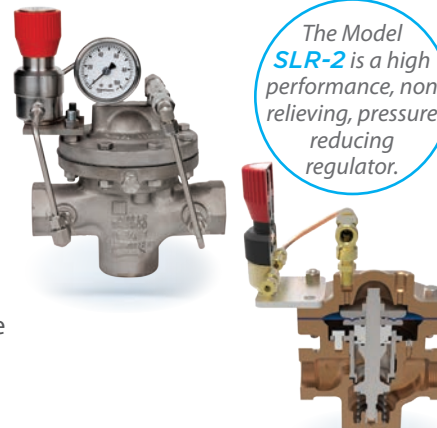

The Model SLR-2 is a high performance, non relieving, pressure reducing regulator.

Body sizes:

1/2", 3/4", 1", 1-1/4", 1-1/2", 2", 2-1/2", 3", 4"

Maximum Cv:

198

Body/Cover Dome Materials

DI/DI, BRZ/BRZ, CS/DI, BRZ/DI, CS/CS, SST/SST, SST/DI, SST/CS

DI = Ductile Iron
SST = Stainless Steel
BRZ = Bronze
CS = Carbon Steel

End connections:

Standard: Female NPT
ASME Flanged: 125#, 150#, 250#, 300#, 600#
DIN Flanged: PN16, PN25, PN40

Temperature range:

-50° to +400°F,
(-45° C to +204° C)

Max Operating Pressure:

3600 psig, (248 barg)

MODEL // P1

The Model P1 is designed for gases and liquids with inlet pressures up to 3600 psig (248 Barg). Standard adjustable outlet ranges from 1-10 psig (.07-.69 Barg) thru 10-750 psig (.69-51.7 Barg). Flow coefficient of 0.02, 0.06, and 0.20 available. This versatile point of use regulator can be ordered with a variety of options to meet your system demands. Standard construction includes a 40 micron integral filter, adjustment knob, and diffusion resistant stainless steel diaphragm.

Body sizes:

1/4", 3/8", 1/2"

Maximum Cv:

.02, .06 and .20

Materials:

Body/Spring chamber 316L SST
Brass/6061 AL

End connections:

FNPT, Tube End, Tri-Clamp

Temperature range:

-45° to 575° F (-42.7° to 301° C)

Pressures:

Max Inlet: 3,600 psig (248.2 Barg)
Max Outlet: 1-750 psig (.07-51.7 Barg)

Options:

Relief Valve



The Model P1 is a single stage high pressure reducing regulator.

MODEL // P2

The Model P2 is designed for gases with inlet pressures up to 3600 psig (248 Barg). Standard adjustable outlet ranges from 1-10 psig (.07-.69 Barg) thru 10-750 psig (.69-51.7 Barg). Flow coefficient of 0.02, 0.06, and 0.20 available. This versatile cylinder gas regulator can be ordered with a variety of options to meet your system demands. Standard construction includes a 40 micron integral filter, adjustment knob, and diffusion resistant stainless steel diaphragm. Gauges and CGA fittings are optional.

Body sizes:

1/4", 3/8", 1/2"

Maximum Cv:

.02, .06 and .20

Materials:

Body/Spring chamber 316L SST
Brass/6061 AL

End connections:

FNPT, CGA End Connection

Temperature range:

-45° to 575° F (-42.7° to 301° C)

Pressures:

Max Inlet: 3,600 psig (248.2 Barg)
Max Outlet: 1-750 psig (.07-51.7 Barg)

Options:

Packed Valve, Diaphragm Valve



The Model P2 is a single stage cylinder gas high pressure reducing regulator.

MODEL // P3

The Model P3 is a 2-stage regulator designed for gases with inlet pressures up to 3600 psig (248 Barg). Standard adjustable outlet ranges from 1-10 (.07-.69 Barg) thru 10-750 psig (.69-51.7 Barg). Flow coefficient of 0.02, 0.06, and 0.20 available. This versatile cylinder gas regulator can be ordered with a variety of options to meet your system demands. Standard construction includes a 40 micron integral filter, adjustment knob, and diffusion resistant stainless steel diaphragm. Gauges and CGA fitting are optional.



The Model P3 is a two stage cylinder high gas pressure reducing regulator.

Body sizes:

1/4", 3/8", 1/2"

Maximum Cv:

.02, .06 and .20

Materials:

Body/Spring chamber 316L SST
Brass/6061 AL

End connections:

FNPT, CGA End Connection

Temperature range:

-45° to 575° F (-42.7° to 301° C)

Pressures:

Max Inlet: 3,600 psig (248.2 Barg)
Max Outlet: 1-500 psig (.07-34.5 Barg)

Options:

Packed Valve, Diaphragm Valve

MODEL // P4

The Model P4 is designed for gases with inlet pressures up to 3600 psig (248 Barg). Standard adjustable outlet ranges from 1-10 psig (.07-.69 Barg) through 10-500 psig (69-34.4 Barg). Flow coefficient of .6 Cv available. This versatile point of use regulator can be ordered with a variety of options to meet your system demands. Standard construction includes a 40 micron integral filter, adjustment knob, and diffusion resistant stainless steel diaphragm.



The Model P4 is a balanced pressure reducing regulator.

Body sizes:

3/8", 1/2"

Maximum Cv:

.6

Materials:

Body/Spring chamber 316L SST
Brass/6061 AL

End connections:

FNPT, Tube End, Tri-Clamp

Temperature range:

-45° to 275° F (-42.7° to 135° C)

Pressures:

Max Inlet: 3,600 psig (248.2 Barg)

Max Outlet: 1-500 psig (.69-34.4 Barg)

Options:

Relief Valve

MODEL // P5

The Model P5 is a piston designed regulator for gases and liquids with inlet pressures up to 3600 psig (248 Barg). Flow coefficient of 0.06. This general purpose use regulator can be ordered with a variety of options to meet your system demands. Standard construction includes a 40 micron integral filter, adjustment knob, and diffusion resistant stainless steel diaphragm.



The Model P5 is a piston designed reducing regulator.

Body size:

1/4", 3/8", 1/2"

Maximum Cv:

.06

Materials:

Body/Spring chamber 316L SST

End connections:

NPT

Temperature range:

-55° to 300° F (-48° to 149° C)

Pressures:

Max Inlet: 3,600 psig (248.2 Barg)

Max Outlet: 50-1,500 psig (3.4-103 Barg)

Options:

Mounting Bracket,
Panel Mount

MODEL // P7

The Model P7 is a piston designed regulator that safely reduces inlet pressures of up to 4500 psig (310 Barg) and accurately delivers high gas flows throughout the 10-1500 psig (.69-103.4 Barg) range. This self-venting unit can be furnished as a non-venting regulator for hydraulic applications.

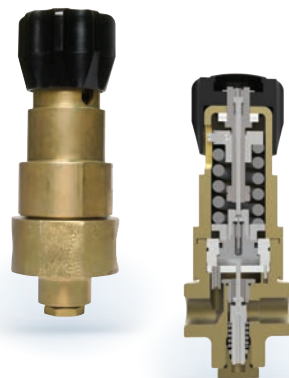

The Model P7 can handle pressure up to 4500 psig.

Body sizes:

1/2", 3/4"

Maximum Cv:

2.0

Materials:

Body/Spring chamber Brass/Brass or
316 SST/316 SST

End connections:

FNPT, 300#, 600#, 1500# Flanges in SST

Temperature range:

-15° to 165° F (-25.0° to 75° C)

Pressures:

Max Inlet: 4500 psig (310.3 Barg)

Max Outlet: 10-1500 (.69-103 Barg)

Options:

Dome Loaded, Ratio Loaded, Panel Mount

// BACK PRESSURE REGULATORS

Just as pressure reducing regulators respond to and control changes in outlet pressure, back pressure regulators respond to and control changes in inlet pressure. These regulators modulate the discharge rate

to maintain a constant pressure on the inlet side. However, back pressure regulators are not safety devices and must not be substituted for code-approved pressure safety relief valves or rupture discs.

MODEL // BQ

The Model BQ is designed for lower flow installations to control flow rates not covered by Model 123. It is often used in economizer circuits. It is also a popular cryogenic regulator and widely used in chemical process services.

Body sizes:

1/4", 3/8", 1/2"

Materials:

Body DI, BRZ, CS, SST
Spring chamber DI, BRZ, SST
BR, 316 SST
Trim Metal-BR, SST –
 Composition-Buna-N,
 TFE, EPR, FKM
Seat Phos. BRZ, 302 SST,
 Neoprene, EPDM,
 Elgiloy

Diaphragm

End connections:

NPT, flanges in ASME or DIN

Temperature range:

-325° F to +600° F,
 (-198° C to +315° C)

Set pressures:

Springs for 5-300 psig,
 (0.34 - 20 barg)

Pressure drop:

Up to 400 psid, (27 bard)

Options:

Closing cap,
 cryogenic construction,
 differential construction

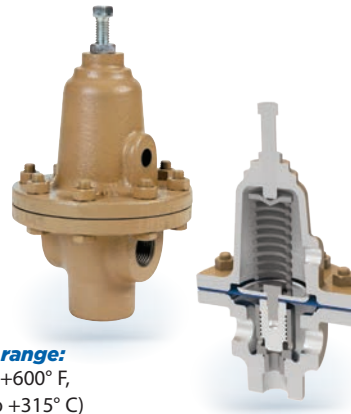

The Model BQ is for lower-flow and cryogenic applications.

MODEL // BR

The Model BR is a versatile back-pressure regulator, available either in a globe style or angular porting configuration. Controlling inlet pressures up to 200 psig, it can be utilized in a majority of the general industrial pressure relief applications.

Body sizes:

3/8", 1/2", 3/4", 1" 1-1/2", 2"

Materials:

Body DI, BRZ, CS, 316 SST
Spring Chamber DI, BRZ, CS, 316 SST
BRZ, 416 SST, 316 SST
Trim Metal - BR, SST, Composition-
 Buna-N, TFE, EPR, Neoprene
Seat Phos. BRZ, 302 SST, Neoprene,
 F.C. Elastomer, EPDM

Diaphragm

End connections:

NPT, BSP, Flanged, Extended Nipples,
 flanges in ASME or DIN

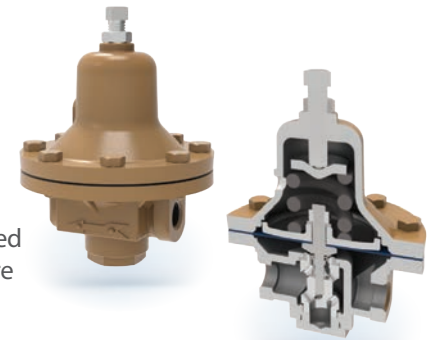

Temperature range:

-325° F to +400° F, (-198° C to +204° C)

Set pressures:

Springs for 2-120 psig, (0.13 - 8 barg)

Pressure drop:

Up to 260 psid, (18 bard)

Options:

Handwheel and locking lever,
 NACE Construction,
 Cleaned for O2 Service

The Model BR is a flow thru, back pressure regulator with set pressures up to 200 psig.

MODEL // 123

With five body materials and twenty-three trim material combinations, the Model 123 is compatible with most fluids. It can handle a wide range of flow and pressure settings to match nearly any back-pressure application up to a 2" line size. The regulator offers four composition seat materials and controlled compression with metal-to-metal back-up for long life and trouble-free operation.



The Model 123 is a highly versatile, back pressure regulator.

Body sizes:

1/2", 3/4", 1", 1-1/2", 2"

Materials:

Body CI, BRZ, CS, LCC, 316 SST
Spring chamber CI, BRZ, CS, LCC, 316 SST
Trim BRZ, 316 SST, 416 SST
Seat Metal – BR, 416 SST, 316 SST, Stellite Composition – Buna-N, TFE, EPR, F.C. Elastomer
Diaphragm Phos. BRZ, 302 SST, Neoprene, F.C. Elastomer, EPDM, Buna N.

End connections:

NPT, flanged, extended nipples, flanges in ASME or DIN

Temperature range:

-325° F to +450° F, (-198° C to +232° C)

Set pressures:

Springs for 2-350 psig, (0.13 - 24 barg)

Pressure drop:

Up to 525 psid, (36 barg)

Options:

Closing cap, cryogenic construction, differential construction, NACE service

MODEL // 1171

The Model 1171 is a back pressure/relief regulator suitable for most liquid and gas applications including pump by-pass and modulating back pressure relief services.

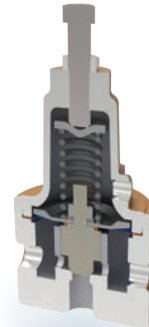

The Model 1171 brass-bodied BPR is for low-flow general service.

Body sizes:

3/8", 1/2"

Materials:

Body Brass
Spring chamber BRZ
Trim BR
Seat Metal – BR
Diaphragm Composition – TFE
End connections: Phos. BRZ, Neoprene, FKM

End connections:

NPT

Temperature range:

-325° F to +400° F, (-198° C to +204° C)

Set pressures:

Springs for 5-200 psig, (0.34 - 13 barg)

Pressure drop:

Up to 400 psid, (27 barg)

Options:

Inlet pressure gauge, panel mounting, cryogenic construction

MODEL // 1164

The Model 1164 back pressure regulator is equipped with a variety of body and trim materials that make it compatible with many fluids and chemicals. Its large orifice and diaphragm combine sensitivity with high capacity.

The Model 1164 is an economical back pressure regulator.

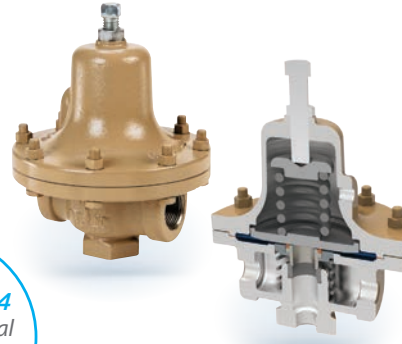

Body sizes:

3/4", 1", 1-1/2", 2"

Materials:

Body DI, BRZ, CS
Spring chamber CI, BRZ, CS
Trim 416 SST, 316 SST
Seat Metal – 316 SST
 Composition – TFE
Diaphragm Phos. BRZ, TFE-coated, 302 SST

End connections:

NPT, BSP

Temperature range:

-20° F to +400° F,
 (-29° C to +204° C)

Set pressures:

Springs for 5-150 psig,
 (0.34 - 10 barg)

Pressure drop:

Up to 225 psid,
 (15 bard)

MODEL // 6987

This heavy-duty, angle-bodied back pressure regulator can handle high inlet and outlet pressures plus high pressure drops. Six range springs provide wide setpoint selection. Applications include fuel, oil, water, inert gases, air and chemicals.

The Model 6987 is a heavy-duty high-pressure back pressure regulator.

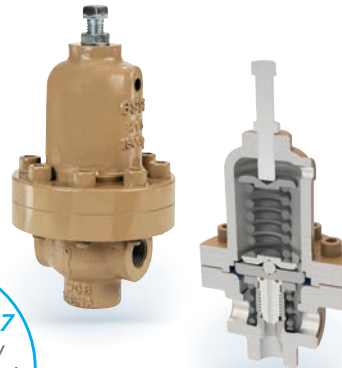

Body sizes:

1/2", 3/4"

Materials:

Body CS, SST
Spring chamber CS
Trim 316 SST
Seat Metal – 316 SST, Stellite
Diaphragm 302 SST

End connections:

Standard – NPT
Optional – Flanged 300# or 600#,
 Plain End Pipe Nipples
 – Flanges in ASME or DIN

Temperature range:

-20° F to +450° F, (-29° C to +232° C)

Set pressures:

Springs for 50-800 psig, (3 - 55 barg)

Pressure drop:

Up to 960 psid, (66 bard)

Options:

Closing cap, reduced
 orifice seats, differential and NACE

MODEL // 2171

Model 2171 is similar in design and capacity to its brass-bodied counterpart, but its SST body and trim enable it to handle an even wider range of fluids.

Model 2171 is a stainless steel low-flow back pressure-regulator.

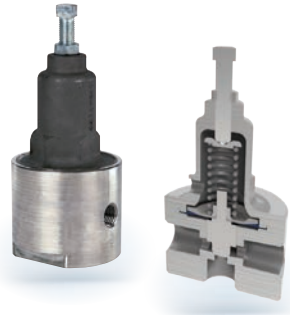

Body sizes:

1/4", 3/8", 1/2"

Materials:

Body 316L SST
 Spring chamber 316 SST, BRZ
 Trim 316 SST
 Seat Metal – 316 SST
 Composition – TFE
 Diaphragm 302 SST, Neoprene, TFE-coated, 302 SST, FL Elastomer

End connections:

NPT, flanged

Temperature range:

-325° F to +400° F, (-198° C to +204° C)

Set pressures:

Springs for 5-500 psig, (0.34 - 34 barg)

Pressure drop:

Up to 600 psid, (41 bard)

Options:

Cryogenic construction, inlet pressure gauge, special pharmaceutical/food industry construction

MODEL // 8311HP & 8311LP

When air and electric controls are not available, these reliable high-capacity regulators can be used in place of control valves. Dual-port construction makes these our highest-capacity back pressure regulators. Both models share the same basic design, differing only in diaphragm size.

The Models 8311HP and 8311LP are high-capacity regulators and ideal for remote installations.

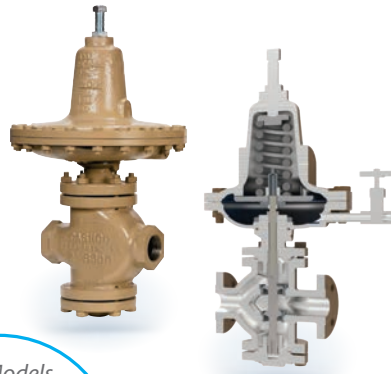

Body sizes:

1-1/2", 2", 2-1/2", 3", 4"

Materials:

Body CI, CS
 Spring chamber CI, DI, CS
 Trim 316 SST
 Seat Metal – 316 SST, Stellite
 Diaphragm 302 SST, Neoprene, F.C. Elastomer

End connections:

1-1/2", 2" – NPT, CI or CS
 All Sizes – 125#, 250# flange, CI
 All Sizes – 150#, 300# flange, CS

Temperature range:

-20° F to +450° F, (-29° C to +232° C)

Set pressures:

8311HP – springs for 10-145 psig, (0.69 - 10 barg) options 130-200 psig, (9 -13 barg)
 8311LP – springs for 1-30 psig, (0.069 - 2 barg)

Pressure drop:

Up to 260 psid, (18 bard)

Options:

Closing cap

MODEL // CA-1 & CA-2

Designed for lower flow applications. It is often used in small pump set applications as well as the cryogenic and compressed gas industry. Metal lapped seats allow for leakage rate to approach levels of composition seats.

The Models CA-1 and CA-2 are compact forged bronze back pressure regulators.

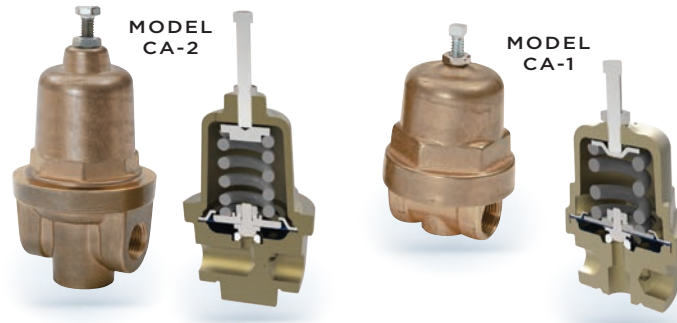

Body sizes:

1/8", 1/4", 3/8" and 1/2"

Flow designs:

Globe, Angle, Flow-thru

Materials:

Body	Forged Bronze, 316 SST
Spring chamber	Bronze, 316 SST
Trim	316 SST
Seat	Metal
Diaphragm	302 SST, Buna-N

End connections:

NPT

Temperature range:

-325° F to +300° F, (-198° to +149° C)

Set pressures:

- CA1 – springs for 2-400 psig, (0.14 - 27 barg)
- CA2 – springs for 3-610 psig, (0.2- 42 barg)

Options:

Closing Caps, Cryogenic, Handwheel and Panel Mounting

MODEL // 31-B

The Model 31-B is a compact relief regulator designed expressly for use as a back pressure regulator or bypass valve for controlling inlet pressure between 2 and 16 inches - W.C. (mm H2O) range. Body is available in cast carbon steel or stainless steel materials only. Interior wetted trims for corrosive applications is standard.

The 31-B is a back pressure regulator that maintains set points as low as 2" W.C.

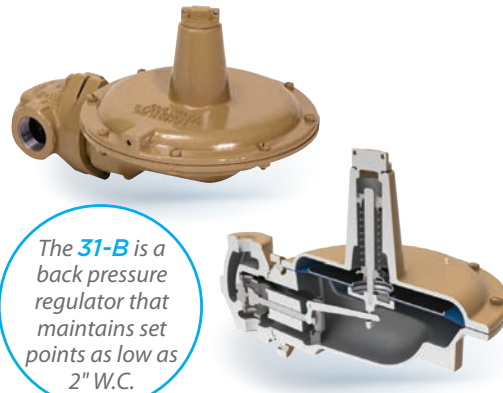

Body sizes:

1/2", 3/4", 1", 1-1/2" and 2"
(20, 25, 40 and 50)

NOTE: Inlet and outlet same size.

Materials:

Body	CS, SST
Spring chamber	CS, SST
Trim	316 SST
Seat	Buna-N, Silicone, TFE, FC, Elastomer
Diaphragm	Buna-N, F.C. Elastomer

End connections:

- Standard: NPT Female
- Option-30: Weld-on 150# RF Flanges
- Option-32: Extended Plain End Nipples

Temperature range:

-30° F to 400° F, (-34° C to +204° C)

Set pressures:

Multiple springs covering 2.0" - 16.0" W.C. (50 - 400 mm H2O), (5 mbarg - 40 mbarg)

Options:

NACE

MODEL // DA-5

The DA5 is an excellent back pressure regulator for all fluid types. The regulator features a high flow design with standard balanced trim. The balanced trim allows rangeability up to 500:1; allowing for varying flows with very little change in set pressure. Due to the high capacities these regulators provide, it is now possible to install regulators where control valves once were needed. This allows additional savings since controllers, positioners, and auxiliary air are not needed. The Model DA8 is similar to this regulator except it provides positive bias differential construction.

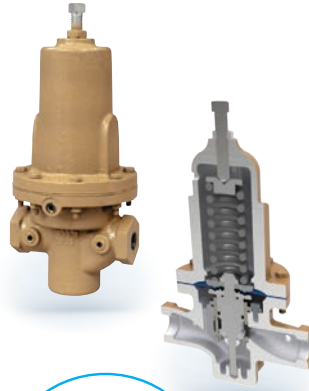

The Model **DA5** is a high capacity self contained back pressure regulator.

Body sizes:

1/2", 3/4", 1", 1-1/4", 1-1/2", 2", 2-1/2", 3", 4"

Maximum Cv:

187

Materials:

Body	BRZ, DI, CS, HC, 316 SST, Duplex SST
Spring chamber	BRZ, DI, CS, 316 SST, Duplex SST
Trim	17-PH SST, 316L SST, Monel
Seat	PolyAll, V-TFE, GF-TFE, C+TFE, FKM
Diaphragm	Composition – BC, EPR, FKM, FK, NBR, FKM + TFE, Elast. TFE Metal – Be-Cu

End connections:

NPT, 125#-250#, 150#-600#
Integral Flanged, PN16, PN25,
PN40 DIN Flanged, Extended
Pipe Nipples or Tube End
Construction

Temperature range:

-425° to +400° F, (-254° C to +204° C)

Set pressures:

Springs for 1-450 psig, (0.07 - 31 barg)

Options:

NACE, Cleaned for O2 Service,
Cleaned for Chlorine Service

MODEL // DA-6

The DA6 is a pressure loaded back pressure regulator for all fluid types. Much like the DA5, the ability to allow varying flows with little change in set pressure makes this an ideal regulator for high accuracy applications. When the precision of automated controls cannot be sacrificed, the dome-loaded series is ideal. The ability to load the regulator with a wide variety of pilots, airsets, and I/P transducers allows for accuracy and automation in a small inexpensive package.



The Model **DA6** is a high capacity pressure loaded back pressure regulator.

Body sizes:

1/2", 3/4", 1", 1-1/4", 1-1/2", 2", 2-1/2", 3", 4"

Maximum Cv:

150

Materials:

Body	BRZ, DI, CS, HC, LCC, 316 SST
Cover Dome	BRZ, DI, CS, LCC, 316 SST
Trim	17-PH SST, 316L SST, Monel
Seat	PolyAll, V-TFE, GF-TFE, C+TFE, FKM
Diaphragm	Composition – BC, EPR, FKM, FK, NBR, FKM + TFE, Elast. TFE Metal – Be-Cu

End connections:

NPT, 125#-250#, 150#-600#
Integral Flanged, PN16, PN25,
PN40 DIN Flanged, Extended Pipe
Nipples or Tube End Construction

Temperature range:

-425° to +400° F, (-254° C to +204° C)

Loading set pressures:

2.0" W.C. - 750 psig, (5 mbarg - 51 barg)

Options:

NACE, Cleaned for O2 Service,
Cleaned for Chlorine Service

MODEL // DA-8

The DA8 is a positive bias differential back pressure regulator for all fluid types. Much like the DA5, the ability to allow varying flows with little change in set pressure makes this an ideal regulator for high accuracy applications.

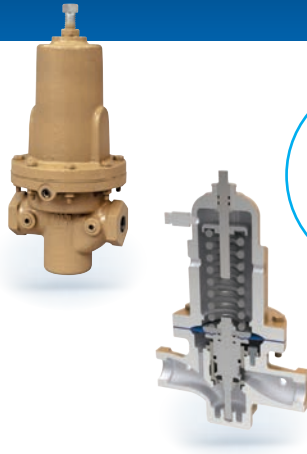

The Model DA8 is a positive bias differential back pressure regulator.

Body sizes:

1/2", 3/4", 1", 1-1/4", 1-1/2", 2", 3", 4"

Maximum Cv:

187

Materials:

Body BRZ, DI, CS, 316 SST
 Spring chamber BRZ, DI, CS, 316 SST
 Trim 17-PH SST, 316L SST, Monel
 Seat PolyAll, V-TFE, GF-TFE, C+TFE, FKM
 Composition – BC, EPR, FKM, FK, NBR, FKM + TFE, Elast. TFE
 Diaphragm Metal – Be-Cu

End connections:

NPT, 125#-250#, 150#-600#
 Integral Flanged, PN16, PN25, PN40 DIN Flanged,
 Extended Pipe Nipples or Tube End Construction

Temperature range:

-425° to +400° F, (-254° C to +204° C)

Set pressures:

Springs for 1 to 200 psig, (70 mbarg - 13 barg)

Options:

Cleaned for O2 Service, Cleaned for Chlorine Service

MODEL // B2

The Model B2 is designed for gases and liquids with control ranges up to 750 psig (51.7 Barg). Flow coefficient of 0.10, 0.20, and 0.30 are available. This versatile back pressure regulator can be ordered with a variety of options to meet your system demands. Standard construction includes an adjustment knob and diffusion resistant stainless steel diaphragm.



The Model B2 is a high pressure back pressure regulator.

Body sizes:

1/4", 3/8", 1/2"

Maximum Cv:

0.1, 0.2 and 0.3

Materials:

Body/Spring chamber 316L SST/316L SST
 Brass/6061 AL

End connections:

FNPT, Tube End, Tri-Clamp

Temperature range:

-45° to 575° F (-42.7° to 301° C)

Set pressures:

Springs for 1-750 psig (.07-51.7 Barg)

MODEL // B7

The Model B7 is a self-contained, back pressure/relief regulator designed to control inlet setpoint pressure between 10-1150 psig.



The Model B7 is a back pressure regulator that maintains set points up to 1150.

Body sizes:

1/2", 3/4" in Angle,
 Globe or Flow-thru pattern

Maximum Cv:

2.5

Body Material:

316L SST or Brass Barstock

Trim:

SST, Brass
 Seat-SST,
 Brass or PTFE, Stellite

Temperature range:

-35° to 400° F,
 (-37° C to +204° C)

Set pressures:

Inlet to 1150 psig,
 (80 barg)



Check out the other high quality product lines
available exclusively from Cashco.



**Sanitary Control Valves
& Regulators**



Vapor Control Systems



Control Valves



**Valve
& Automation**
Total Valve & Control Solutions®

JOHANNESBURG
Tel: 011 397 2833

DURBAN
Tel: 031 579 2593

**South Africa: 0861 103
103**

E-mail: sales@valve.co.za
www.valve.co.za



SCAN ME