

# MODELS D and DL

## PRESSURE REDUCING REGULATORS

### SECTION I

#### I. DESCRIPTION AND SCOPE

The Model D is a pressure reducing regulator used to control downstream (outlet or  $P_2$ ) pressure. Sizes are 3/8" (DN10), 1/2" (DN15), 3/4" (DN20) and 1" (DN25). With proper trim utilization, the unit is suitable for liquid, gaseous, or steam service. Refer to Technical Bulletin D-TB for design conditions and selection recommendations.

The Model DL is also a pressure reducing regulator similar to above Model D. Sizes are 1-1/2" (DN40) and 2" (DN50). (Model DL was formerly a Cashco Model D). Refer to Technical Bulletin DL-TB for design conditions and selection recommendations.

### SECTION II

#### II. INSTALLATION



**CAUTION**

**For welded installations, all internal trim parts, seals and diaphragm(s) must be removed from regulator body prior to welding into pipeline. The heat of fusion welding will damage non-metallic parts if not removed. NOTE: This does not apply to units equipped with extended pipe nipples.**

1. An inlet block valve should always be installed.
2. If service application is continuous such that shutdown is not readily accomplished, it is recommended that an inlet block valve, outlet block valve, and a manual bypass valve be installed.
3. Pipe unions should be installed to allow removal from piping.
4. An outlet pressure gauge should be located approximately ten pipe diameters downstream and within sight.
5. All installations should include a downstream relief device if the inlet pressure could exceed the pressure rating of any downstream equipment or the maximum outlet pressure rating of the unit.

**CAUTION**

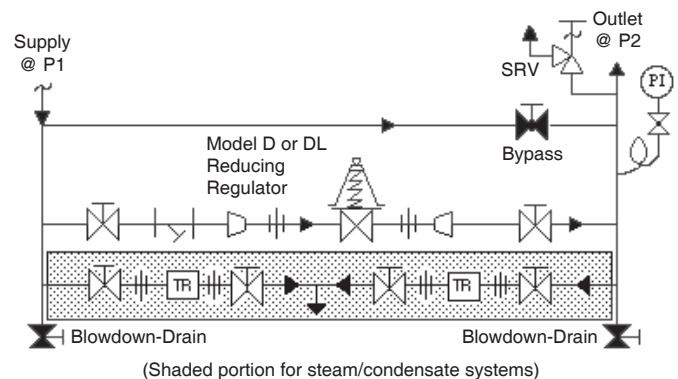
**Installation of adequate overpressure protection is recommended to protect the regulator from overpressure and all downstream equipment from damage in the event of regulator failure.**



Recommended Piping Schematic  
For Pressure Reducing Station

6. Clean the piping of all foreign material including chips, welding scale, oil, grease and dirt before installing the regulator. Strainers are recommended.
7. In placing thread sealant on pipe ends prior to engagement, ensure that excess material is removed and not allowed to enter the regulator upon startup.
8. Flow Direction: Install so the flow direction matches the arrow cast on the body.
9. For best performance, install in well drained horizontal pipe, properly trapped, if a steam service application.
- 10.A. Basic Regulator - (Refer to Figure 2): Regulator may be rotated around the pipe axis 360°. Recommended position is with spring chamber vertical upwards. Orient such that the spring chamber vent hole does not collect rainwater or debris.



## CAUTION

**DO NOT HYDROSTATIC TEST THROUGH AN INSTALLED UNIT; ISOLATE REGULATOR FROM TEST. The upper range spring pressure level listed on the nameplate or 100 psig (6.9 Barg) minimum is the recommended “upper operative limit” for the sensing diaphragm (see Section IV. Startup, Number 7.) Higher pressures could cause internal damage. In addition, note on the nameplate that the Inlet and Outlet pressure and temperature ratings are at different levels.**

10.B. Model D Cryogenic Regulator - Option D-5 or D-36  
(Refer to Figure 4):

a. Recommended installation is with spring chamber hanging directly below the body in a vertical downwards orientation. Allows water to drain; i.e. rainwater, etcetera.

b. Recommend inert purge gas to spring chamber through vent hole and out drain hole.

11. Regulators are not to be direct buried underground.

12. For insulated piping systems, recommendation is to not insulate regulator.

13. Spring Chamber Vent Tap - Option D-25 or DL-25: Pipe spring chamber vent opening to remote location. Orient so as not to take on rainwater.

## SECTION III

### III. PRINCIPLE OF OPERATION

1. Movement occurs as pressure variations register on the diaphragm. The registering pressure is the outlet,  $P_2$ , or downstream pressure. The range spring or loading pressure (Opt.-20) opposes diaphragm movement. As outlet pressure drops,

the range spring or loading pressure pushes the diaphragm down, opening the port; as outlet pressure increases, the diaphragm pushes up and the port opening closes.

2. A complete diaphragm failure will cause the regulator to fail open.

## SECTION IV

### IV. STARTUP

1. Start with the block valves closed. A bypass valve may be used to maintain outlet pressure in the downstream system without changing the following steps.

2. Relax the range spring by turning the adjusting screw counter clockwise (CCW) a minimum of three (3) full revolutions or reduce loading pressure (Opt.-20). This reduces the outlet (downstream) pressure set point.

3. If it is a “hot” piping system, and equipped with a bypass valve, slowly open the bypass valve to pre-heat the system piping and to allow slow expansion of the piping. Ensure proper steam trap operation if installed. Closely monitor outlet (downstream) pressure via gauge to ensure not over-pressurizing. **NOTE:** *If no bypass valve is installed, extra caution should be used in starting up a cold system; i.e. do everything slowly.*

4. Crack open the outlet (downstream) block valve.

5. Slowly open the inlet (upstream) block valve observing the outlet (downstream) pressure gauge. Determine if the regulator is flowing. If not, slowly rotate the regulator adjusting screw (6) clockwise (CW) or increase loading pressure (Opt.-20) until flow begins.

6. Continue to slowly open the inlet (upstream) block valve until fully open.

7. Continue to slowly open the outlet (downstream) block valve, especially when the downstream piping system isn't pressurized. If the outlet (downstream) pressure exceeds the desired pressure, close the block valve and go to Step 2, then return to Step 4.

8. When flow is established steady enough that the outlet (downstream) block valve is fully open, begin to slowly close the bypass valve if installed.

9. Develop system flow to a level near its expected normal rate, and reset the regulator set point by turning the adjusting screw (6) CW to increase outlet pressure, or CCW to reduce outlet pressure.

10. Reduce system flow to a minimum level and observe set point. Outlet pressure will rise from the set point of Step 9. The maximum rise in outlet pressure on decreasing flow should not exceed the stated upper limit of the range spring by greater than 10%; i.e. 10-40 psig (.69 - 2.8 Barg) range spring, at low flow the outlet pressure should not exceed 44 psig (3 Barg), if it does, consult factory.

## SECTION V

### V. SHUTDOWN

1. On systems with a bypass valve, and where system pressure is to be maintained as the regulator is shut down, slowly open the bypass valve while reducing the loading pressure (Opt.-20) and slowly closing the inlet (upstream) block valve. When all loading pressure is relieved, fully close the inlet (upstream) block valve. (When on bypass, the system pressure must be constantly observed and manually regulated.) Close the outlet (downstream) block valve.



#### CAUTION

**Do not walk away and leave a bypassed regulator unattended!**

2. If the regulator and system are to both be shutdown, remove all loading pressure while slowly closing the inlet (upstream) block valve. Close the outlet (downstream) valve only if regulator removal is required.

## SECTION VI

### VI. MAINTENANCE

#### A. General:



#### WARNING

**SYSTEM UNDER PRESSURE. Prior to performing any maintenance, isolate the regulator from the system and relieve all pressure. Failure to do so could result in personal injury.**

1. Maintenance procedures hereinafter are based upon removal of the regulator unit from the pipeline where installed.
2. Owner should refer to owner's procedures for removal, handling, cleaning and disposal of nonreusable parts, i.e. gaskets, etc.
3. Refer to Figure 2 for basic regulator. Refer to Figure 4 for cryogenic regulator. For blow-ups of Option-4 Stabilizer, refer to Figure 3.

#### B. Diaphragm Replacement:



#### WARNING

**SPRING UNDER COMPRESSION. Prior to removing flange bolts, relieve spring compression by backing out the adjusting screw. Failure to do so may result in flying parts that could cause personal injury.**

1. Securely install the body (1) in a vise with the spring chamber (2) loading chamber (33) directed upwards.
2. Relax range spring (14) by turning adjusting screw (6) CCW until removed from spring chamber (2). **NOTE:** If the D-3 Option handwheel is utilized, the adjusting screw (6) and locknut (7) are replaced respectively by handwheel adjusting screw (20) and locking lever (21). Refer to Figure 1.

3. Draw or embed a match mark between body casting (1) and spring chamber casting (2) loading chamber (33) along flanged area.
4. Remove all diaphragm nuts (9) and bolts (8).
5. Remove spring chamber (2), (loading chamber 33), range spring (14), spring button (4), pressure plate (3) and diaphragm(s) (12). **NOTE:** Refer to the quantity of diaphragms (12) incorporated per the bill of materials listing. Depending on outlet pressure level, multiple metal diaphragms may be "stacked".
6. Remove pusher plate (11) and inspect for a fit which limits its travel to a vertical direction. Wear will show as excessive wobble in pusher plate (11). If apparent, recommend trim removal and inspection; go to Sub-Section C following. Reinstall pusher plate (11).
7. Inspect pressure plate (3) to ensure no deformation due to over-pressurization. If deformed, replace.
8. Clean body (1) and diaphragm flange. **NOTE:** On regulators originally supplied as "oxygen clean", Option D-5, D-36, D-55, or DL-55, maintenance must include a level of cleanliness equal to Cashco cleaning standard #S-1134. On regulators originally supplied as "cleaned for Pharmaceutical and Food applications" Option D-37 or D-37S, maintenance must include a level of cleanliness equal to Cashco cleaning standard #S-1576.
9. Place diaphragm gasket (13) on body (1) flange. Position diaphragm(s) (12) into place. Visually center pressure plate (3) onto diaphragm(s) (12), and set range spring (14) onto retainer hub of pressure plate (3). (Opt.-20 does not utilize spring skip to step 11.) **NOTE:** No diaphragm gasket (13) for composition diaphragm.

10. Place multi-purpose, high temperature grease into depression of spring button (4) where adjusting screw bears. Set spring button (4) onto range spring (14); ensure spring button (4) is laying flat.
11. Aligning the matchmarks, place spring chamber (2) over the above stacked parts. Install all bolts (8) and nuts (9) by hand tightening. Mechanically tighten bolting (8 & 9) in a cross pattern that allows spring chamber (2) to be pulled down evenly. Recommended torque values are as follows:

Model	Regulator Size	Bolt Size	Metal Diaphragm	Comp. Diaphragm
D	3/8" thru 1" (DN10 thru 25)	5/16"-24	20-24 Ft-Lbs (27-32 N-m)	16-20 Ft-Lbs (22-27 N-m)
DL	1-1/2" (DN40)	7/16"-20	32-36 Ft-Lbs (43-49 N-m)	28-32 Ft-Lbs (38-43 N-m)
	2" (DN50)	1/2"-20	42-48 Ft-Lbs (57-65 N-m)	32-36 Ft-Lbs (43-49 N-m)

**NOTE:** Never replace bolting (8 & 9) with just any bolting if lost. Bolt heads and nuts are marked with specification identification markings. Use only proper grades as replacements.

12. Reinstall adjusting screw (6) with locknut (7).
13. Spray liquid leak detector around bolting (8 & 9) and body (1) and spring chamber (2) flanges and test for leakage. Ensure that an outlet pressure is maintained during this leak test of at least mid-range spring level; i.e. 10-40 psig (.69 - 2.8 Barg) range spring, 25 psig (1.7 Barg) test pressure minimum.

### C. Trim Replacement:

1. Install body (1) in a vise with the body cap (5) on top and the body (1) flange downwards.
2. Loosen and remove body cap (5).
3. Remove piston spring (17), piston (15), cylinder (16) and pusher plate (11). For Opt.-20 do not remove pusher plate (11). Inspect parts for excessive wear, especially at seat surfaces. Replace if worn, nicked or depressed. (Valves equipped with Opt-4 Stabilizer will have the u-cup stabilizer seal (32) removed when the piston (15) is removed from body (1). Remove stabilizer seal (32), if installed).
4. Remove the cylinder gasket (18) and clean contacting surface of body (1).
5. Clean flat mating surfaces of body (1) to body cap (5) shoulder.

6. Clean debris from within body (1) cavity. Clean parts to be reused.

**NOTE:** On regulators originally supplied as "oxygen clean", Option D-5, D-36, D-55, or DL-55, maintenance must include a level of cleanliness equal to Cashco cleaning standard #S-1134. On regulators originally supplied as "cleaned for Pharmaceutical and Food applications", Option D-37 or D-37S, maintenance must include a level of cleanliness equal to Cashco cleaning standard #S-1576. Contact factory for details.

7. Reinstall the pusher plate (11). Ensure proper position of flat surface being downwards. Ensure centered.
8. Reinstall a new cylinder gasket (18). Press firmly and evenly into place using the cylinder (16). Do not use a "homemade" cylinder gasket. Pipe sealant may be lightly coated to cylinder gasket (18) surfaces prior to installation, except when utilized as Item 6 above.
9. Reinstall the cylinder (16) concentrically within the body cap (5) opening.
10. If supplied with Opt-4 Stabilizer, install new stabilizer seal (32) properly oriented onto piston (15). See Figure 4.
11. Slide the piston (15), including stabilizer seal (32) if supplied, slowly into place, assuring that the piston (15) post slides into the female groove of the pusher plate (11). Use thumbs to ease stabilizer seal (32) into cylinder (16).
12. Place piston spring (17) into piston (15) cavity.
13. Use pipe thread sealant applied to the body cap (5) threads. Thread body cap (5) into body (1). For all sizes of the **Ductile Iron and SST** body caps -impact until body cap (5) is metal to metal against body (1) at the body cap (5) shoulder.  
  
**For 3/8" & 1/2" size with bronze** body cap - tighten cap to between 70 - 80 Ft-Lbs torque.  
**For 3/4" & 1" size with bronze** body cap - tighten cap to between 125-150 Ft-Lbs.
14. Bench test unit for suitable operation. **NOTE:** Regulators are not tight shutoff devices. Even if pressure builds up beyond set point, a regulator may or may not develop bubble tight shutoff. In general, tighter shutoff can be expected with composition seat.
15. Spray liquid leak detector around body cap (5) and body (1) for test for leakage. Test pressure should be a minimum of 100 psig (6.9 Barg) at

the inlet. Outlet should be tested to upper value of range spring (14) with a 100 psig (6.9 Barg) minimum.

**NOTE:** When piston (15) assemblies are used with comp seats, Cashco, Inc. does not recommend attempting to remove the comp seat. If composition seat is damaged, replace entire piston assembly.

## SECTION VII

### VII. TROUBLE SHOOTING GUIDE

#### 1. Erratic operation; chattering.

Possible Causes	Remedies
A. Oversized regulator.	A1. Check actual flow conditions, resize regulator for minimum and maximum flow. A2. Decrease regulator pressure drop; decrease inlet pressure by placing a throttling orifice in inlet piping union; 2-stage pressure drop by using with another regulator in series. A3. Install next step higher range spring. Contact factory. A4. Before replacing regulator, contact factory.
B. Inadequate rangeability (regulator full capacity approximately 50% utilized).	B1. Decrease regulator pressure drop; decrease inlet pressure by placing a throttling orifice in inlet piping union; 2-stage pressure drop by using with another regulator in series. B2. Install next step higher range spring. Contact factory.
C. Worn piston/cylinder; inadequate guiding.	C. Replace trim.
D. Weakened/broken piston spring.	D. Replace piston spring. Determine if corrosion is causing the failure; if so, then consider alternate trims.
E. Flow induced instability.	E. Replace piston with piston that includes Opt-4 Stabilizer seal.

#### 2. Downstream pressure will not reach desired setting.

Possible Causes	Remedies
A. Regulator undersized.	A1. Confirm by opening bypass valve together with regulator. A2. Check actual flow conditions, resize regulator; if regulator has inadequate capacity, replace with larger unit.
B. Plugged trim.	B. Remove trim and check for plugged holes in cylinder.
C. Incorrect range spring (screwing in CW of adjusting screw does not allow bringing pressure level up to proper level).	C. Replace range spring with proper higher range. Contact factory.
D. Too much proportional band (droop).	D1. Review P.B. (droop) expected. D2. Contact factory.
E. Restricted diaphragm movement.	E. Ensure no moisture in spring chamber at temperatures below freeze point. Ensure no dust or debris entering vent opening. If rainwater or debris can enter, re-orient spring chamber.

#### 3. Leakage through the spring chamber vent hole.

Possible Causes	Remedies
A. Normal-life diaphragm failure.	A. Replace diaphragm.
B. Abnormal short-life diaphragm failure.	B1. Can be caused by excessive chattering. See No. 1. to remedy chatter. B2. Can be caused by corrosive action. Consider alternate diaphragm material. B3. For composition diaphragms, ensure not subjecting to over-temperature conditions. B4. Downstream (outlet) pressure buildup occurring that overstresses diaphragms. Relocate regulator or protect with safety relief valve.

**4. Excessive pressure downstream.**

Possible Causes	Remedies
A. Regulator not closing tightly.	A. Inspect the seating. Clean and lap metal seat surfaces; replace if lapping does not remedy. If composition seats are depressed, nicked or embedded with debris, replace trim.
B. Downstream block.	B. Check system; isolate (block) flow at regulator inlet - not outlet. Relocate regulator if necessary..
C. No pressure relief protection.	C. Install safety relief valve, or rupture disc.
D. Restricted diaphragm movement.	D. Ensure no moisture in spring chamber at temperatures below freeze point. Ensure no dust or debris entering vent opening. If rainwater or debris can enter, re-orient spring chamber.

**5. Sluggish operation.**

Possible Causes	Remedies
A. Plugged spring chamber vent.	A. Clean vent opening.
B. Plugged piston balance port.	B. Remove trim and clean balance port.
C. Fluid too viscous.	C. Heat fluid. Contact factory.

**SECTION VIII**

**VIII. ORDERING INFORMATION**

**NEW REPLACEMENT UNIT vs PARTS "KIT" FOR FIELD REPAIR**

To obtain a quotation or place an order, please retrieve the Serial Number and Product Code that was stamped on the metal name plate and attached to the unit. This information can also be found on the Bill of Material ("BOM"), a parts list that was provided when unit was originally shipped. (Serial Number typically 6 digits). Product Code typical format as follows: (last digit is alpha character that reflects revision level for the product).

□□□□ - □□□□ 7 - □□□□□□□□□□

**NEW REPLACEMENT UNIT:**

Contact your local Cashco, Inc., Sales Representative with the Serial Number and Product code. With this information they can provide a quotation for a new unit including a complete description, price and availability.

**PARTS "KIT" for FIELD REPAIR:**

Contact your local Cashco, Inc., Sales Representative with the Serial Number and Product code. Identify the parts and the quantity required to repair the unit from the "BOM" sheet that was provided when unit was originally shipped.

**NOTE:** *Those part numbers that have a quantity indicated under "Spare Parts" in column "A" reflect minimum parts required for inspection and rebuild, - "Soft Goods Kit". Those in column "B" include minimum trim replacement parts needed plus those "Soft Goods" parts from column "A".*

If the "BOM" is not available, refer to the cross-sectional drawings included in this manual for part identification and selection.

A Local Sales Representative will provide quotation for appropriate Kit Number, Price and Availability.

 **CAUTION**

**Do not attempt to alter the original construction of any unit without assistance and approval from the factory. All purposed changes will require a new name plate with appropriate ratings and new product code to accommodate the recommended part(s) changes.**

The contents of this publication are presented for informational purposes only, and while every effort has been made to ensure their accuracy, they are not to be construed as warranties or guarantees, express or implied, regarding the products or services described herein or their use or applicability. We reserve the right to modify or improve the designs or specifications of such product at any time without notice. Cashco, Inc. does not assume responsibility for the selection, use or maintenance of any product. Responsibility for proper selection, use and maintenance of any Cashco, Inc. product remains solely with the purchaser.

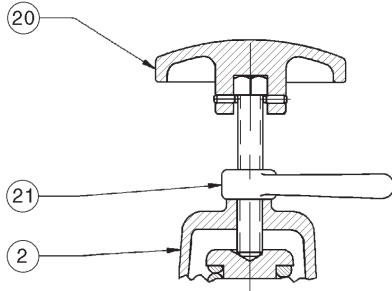

**Figure 1:** Option D-3 or DL-3 Handwheel and Locking Lever

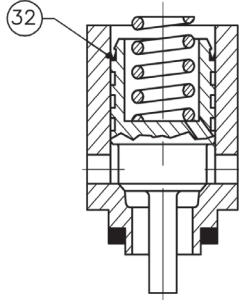

**Figure 3:** Option-4 - Stabilizer

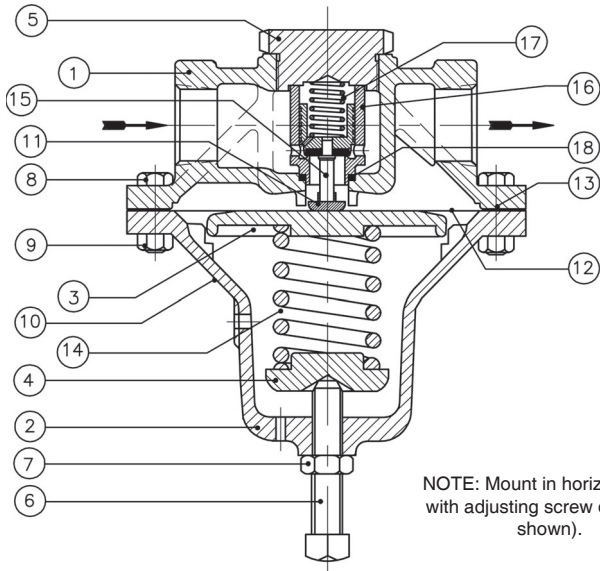

**Figure 4:** Option D-5 or D-36 Cryogenic Model D Metal Diaphragm

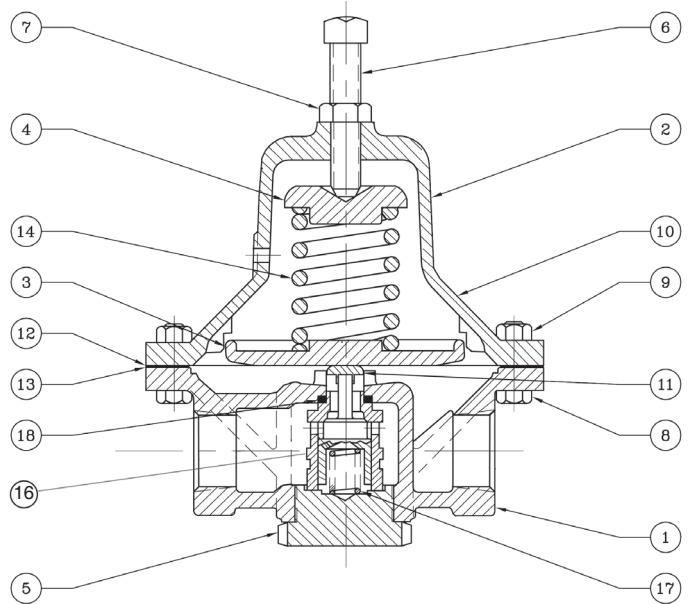

**Figure 2:** Basic Model D - Comp Diaphragm

Item No.	Description	Repair Parts	
		Kit A	Kit B
1	Body		
2	Spring Chamber		
3	Pressure Plate		
4	Spring Button		
5	Body Cap		
6	Adjusting Screw		
7	Nut (hex Jam)		
8	Cap Screw (Flange Bolting)		
9	Nut (Hex) (Flange Bolting)		
10	Name Plate		
11	Pusher Plate		**
12	Diaphragm	*	**
13	Diaphragm Gasket	*	**
14	Range Spring		
15	Piston		**
16	Cylinder		**
17	Piston Spring		**
18	Cylinder Gasket	*	**
20	Handwheel Assembly		
21	Handwheel Locking Lever		
32	Stabilizer Seal <sup>1</sup>	*	**
33	Loading Chamber		
Not Shown:			
27	Gauge		
28	Bushing		

<sup>1</sup> NOT included in kits - must order additionally.

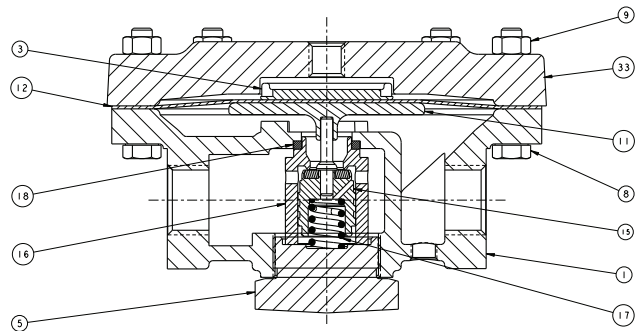

**Figure 5:** Option-20 - Pressure Loaded



IOM ADDENDUM:

ATEX DIRECTIVE 2014/34/EU and THE EQUIPMENT AND PROTECTIVE SYSTEMS INTENDED FOR USE IN POTENTIALLY EXPLOSIVE ATMOSPHERES REGULATIONS 2016

Cashco, Inc. declares that the products listed in the table below has been found to comply with the Essential Health and Safety Requirements relating to the design and construction of products intended for use in potentially explosive atmospheres given in Annex II of the ATEX Directive 2014/34/EU and given in Schedule 1 of The Equipment and Protective Systems Intended for Use in Potentially Explosive Atmospheres Regulations 2016. Compliance with the Essential Health and Safety Requirements has been assured by compliance with EN ISO 80079-36:2016 and EN ISO 80079-37:2016. The product will be marked as follows:



The 'X' placed after the technical file number indicates that the product is subject to specific conditions of use as follows:

1. The maximum surface temperature depends entirely on the operating conditions and not the equipment itself. The combination of the maximum ambient and the maximum process medium temperature shall be used to determine the maximum surface temperature and corresponding temperature classification, considering the safety margins described prescribed in EN ISO 80079-36:2016, Clause 8.2. Additionally, the system designer and users must take precautions to prevent rapid system pressurization which may raise the surface temperature of system components and tubing due to adiabatic compression of the system gas. Furthermore, the Joule-Thomson effect may cause process gases to rise in temperature as they expand going through a regulator. This could raise the external surface temperature of the regulator body and the downstream piping creating a potential source of ignition. Whether the Joule-Thomson effect leads to heating or cooling of the process gas depends on the process gas and the inlet and outlet pressures. The system designer is responsible for determining whether the process gas temperature may raise under any operating conditions.
2. Where the process medium is a liquid or semi-solid material with a surface resistance in excess of  $1G\Omega$ , special precautions shall be taken to ensure the process does not generate electrostatic discharge.
3. Special consideration shall be made regarding the filtration of the process medium if there is a potential for the process medium to contain solid particles. Where particles are present, the process flow shall be  $<1\text{m/s}$  ( $<3.3\text{ft/s}$ ) in order to prevent friction between the process medium and internal surfaces.
4. Effective earthing (grounding) of the product shall be ensured during installation.
5. The valve body/housing shall be regularly cleaned to prevent build up of dust deposits.
6. Regulators must be ordered with the non-relieving option (instead of the self-relieving option) if the process gas they are to be used with is hazardous (flammable, toxic, etc.). The self-relieving option vents process gas through the regulator cap directly into the atmosphere while the non-relieving option does not. Using regulators with the self-relieving option in a flammable gas system could create an explosive atmosphere in the vicinity of the regulator.
7. Tied diaphragm regulators with outlet ranges greater than 7 barg (100 psig) should be preset to minimize the risk that improper operation might lead to an outboard leak and a potentially explosive atmosphere.
8. All equipment must only be fitted with manufacturer's original spare parts.
9. Ensure that only non-sparking tools are used, as per EN 1127-1, Annex A.

	PRODUCT
<b>REGULATORS</b>	31-B, 31-N
	1164, 1164(OPT-45)
	1171, 1171(OPT-45), 1171(CRYO)
	2171, 2171(OPT-45), 2171(CRYO), 3171
	1465, 3381, 3381(OPT-45), 3381(OPT-40)
	4381, 4381(OPT-37), 4381(CRYO), 4381(OPT-45), 5381
	MPRV-H, MPRV-L
	PBE, PBE-L, PBE-H
	CA-1, CA-2
	CA1, SA1, CA4, SA4, CA5, SA5
	DA2, DA4, DA5, DA6, DA8
	DA0, DA1, DAP, SAP
	SLR-1, SLR-2, PTR-1
	ALR-1, ULR-1, PGR-1
	BQ, BQ(OPT-45), BQ(CRYO)
	123, 123(CRYO), 123(OPT-45), 123(OPT-46G)
	123-1+6, 123-1+6(OPT-45), 123-1+6(OPT-46G), 123-1+6+S, 123-1+6+S(OPT-40)
	1000HP, 1000HP(OPT-37), 1000HP(OPT-45), 1000HP(OPT-45G), 1000HP(CRYO)
	1000HP-1+6, 1000HP-1+8, 1000LP, 1000LP(OPT-45), 1000LP(OPT-46G)
	6987
	8310HP, 8310HP-1+6, 8310HP-1+8, 8310LP, 8311HP, 8311LP
	345, 345(OPT-45)
	BA1/BL1, PA1/PL1
	C-BPV, C-PRV, C-CS
	D, D(CRYO), D(OPT-37), D(OPT-20), D(OPT-45)
	DL, DL(LCC), DL(OPT-45)
	BR, BR(CRYO)
	HP, HP(LCC), HP(OPT-45), HP(OPT46G), HP-1+6+S(OPT-40), HP-1+6+S
	P1, P2, P3, P4, P5, P7
	B2, B7
	POSR-1, POSR-2
	5200P, 5300P
135	
NW-PL, NW-SO	
CG-PILOT	
FG1	
<b>CONTROL VALVES</b>	RANGER, 987, PREMIER
	964, 521, 988, 988-MB, 989
	2296/2296HF
	SCV-30, SCV-S
<b>TANK BLANKETING</b>	8700, 8910, 8920, 8930, 8940
	2100, 2199
	3100, 3200, 3300, 3400, 3500, 3600, 3700
	1078, 1088, 1100, 1049
	5100, 5200, 5400, 5500
	4100, 4200, 4300, 4400, 4500, 4600
<b>MISC</b>	764P/PD, 764-37, 764T

IOM-D/DL

