

MODEL DA1

DA1 - DIRECT-ACTING, SPRING LOADED PRESSURE REDUCING REGULATOR

SECTION I

I. DESCRIPTION AND SCOPE

The Model DA1 is a pressure reducing regulator used to control downstream (outlet or P2) pressure. Sizes are 1/2" (DN15), 3/4" (DN20), 1" (DN25), 1-1/4" (DN32), 1-1/2" (DN40), 2" (DN50), 3" (DN80) and 4" (DN100). With proper trim utilization, the unit is suitable for liquid, gaseous, or steam service. Refer to Technical Bulletin DA1-TB for design conditions and selection recommendations. (**NOTE:** This product was formerly identified as a Model D1; a Model DA1 and D1 are one and the same product.)

SECTION II

II. REFERENCES

Refer to Technical Bulletin DA1-TB and DAG-TB for technical specifications of a Model DA1 regulator.

ABBREVIATIONS

CCW – Counter Clockwise
CW – Clockwise
ITA – Inner Trim Assembly

SECTION III

III. INSTALLATION



CAUTION

For welded installations, all internal trim parts, seals and diaphragm(s) must be removed from regulator body prior to welding into pipeline. The heat of fusion welding will damage non-metallic parts if not removed. NOTE: This does not apply to units equipped with extended pipe nipples.

1. Regulator may be rotated around pipe axis 360 degrees. For ease of maintenance, the recommended position is with the spring chamber (4) upwards. In liquid service it is recommended that the spring chamber (4) be oriented downwards, and that a customer supplied and installed vent valve be provided at the external sensing connection to bleed-off trapped gas/air under the diaphragm.
2. Provide space below, above, and around regulator for removal of parts during maintenance.
3. Install block valves and pressure gauges to provide means for adjustment, operation, bypass, or removal of the regulator. A pipeline strainer is recommended before inlet to remove typical

pipeline debris from entering valve and damaging internal "soft goods", primarily the dynamic seal(27) and the V-TFE seat (21) when applied.

4. Downstream Sensing Installation Considerations – Internal or External Sensing:
 - a. The regulator may be installed with internal or external sensing. Unless otherwise specified, the regulator is supplied by factory with internal sensing. The regulator may be converted in the field to external sensing (see Section VII Maintenance, Paragraph H).
 - b. Reference DAG-TB, Table DAG-11 for recommendations for applying external pressure sensing.
 - c. For internal sensing, no external line is required. For external sensing, use an external control line. The line is connected from the port (1/4" NPT) on the side of the body diaphragm flange (see port 5 in Fig. 5) to a pressure tap 10 to 15 pipe diameters downstream of the regulator. Use 1/4" or 3/8" outer diameter tubing or 3/8" (DN10) pipe having an inner diameter equivalent to schedule 40 pipe.
 - d. For condensable vapors (i.e. steam) slope the external sensing line downward 2 to 5 degrees to outlet piping to prevent water pockets,

which allows the diaphragm chamber to always be self draining. The external sensing line may be sloped upward for liquids or gases.

CAUTION

DO NOT HYDROSTATIC TEST THROUGH AN INSTALLED UNIT; ISOLATE REGULATOR FROM TEST. The upper range spring pressure level on the nameplate is the recommended “upper operating limit” for the sensing diaphragm. Higher pressures could cause internal damage. In addition, note on the nameplate that the Inlet and Outlet pressure and temperature ratings are at different levels.

CAUTION

Installation of adequate overpressure protection is recommended to protect the regulator from overpressure and all downstream equipment from damage in the event of regulator failure.

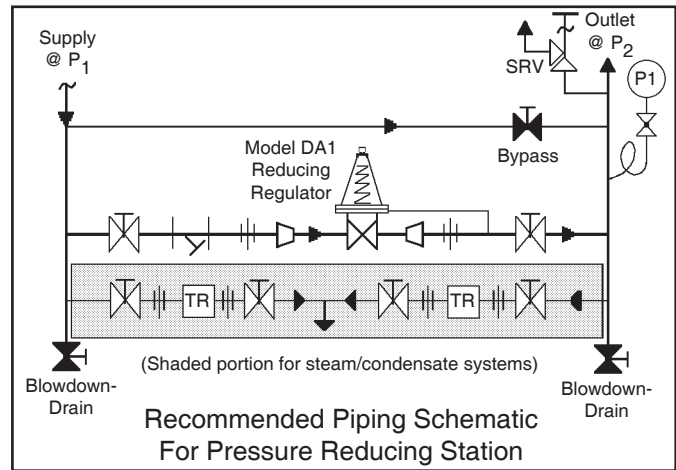

SECTION IV

IV. PRINCIPLE OF OPERATION

1. Movement occurs as pressure variations register on the diaphragm. The registering pressure is the outlet, P2, or downstream pressure. The range spring opposes diaphragm movement. As outlet pressure drops, the range spring pushes the diaphragm down, opening the port; as outlet pressure

increases, the diaphragm pushes up and the port opening closes.

2. A complete diaphragm failure will cause the regulator to fail open and fluid will discharge from the spring chamber vent hole.

SECTION V

V. STARTUP

1. Start with the block valves closed.
2. Relax the range spring by turning the adjusting screw CCW (viewed from above) a minimum of three (3) full revolutions. This reduces the outlet (downstream) pressure set point.
3. If it is a “hot” piping system, and equipped with a bypass valve, partially open the bypass valve to preheat the system piping and to allow slow expansion of the piping. Ensure proper steam trap operation if installed. Closely monitor outlet (downstream) pressure via gauge to ensure not over-pressurizing. **NOTE: If no bypass valve is installed, extra caution should be used in starting up a cold system; i.e. do everything slowly.**
4. Crack open the outlet (downstream) block valve.

5. Slowly open the inlet (upstream) block valve to about 25% open, observing the outlet (downstream) pressure gauge. Determine if the regulator is flowing. If not, slowly rotate the regulator adjusting screw CW (viewed from above) until flow begins.
6. Continue to slowly open the inlet (upstream) block valve until fully open.
7. Continue to slowly open the outlet (downstream) block valve, especially when the downstream piping system isn't pressurized. If the outlet (downstream) pressure exceeds the desired pressure, close the inlet block valve and go to Step 2. Close bypass valve approximately 25%, and repeat procedure.
8. When flow is established steady enough that the outlet (downstream) block valve is fully open, begin to slowly close the bypass valve if installed.

CAUTION

Do not walk away and leave a bypassed regulator unattended!

9. Develop system flow to a level near its expected normal rate, and reset the regulator set point by turning the adjusting screw CW to increase outlet pressure, or CCW to reduce outlet pressure.
10. Reduce system flow to a minimum level and observe pressure set point. Outlet pressure will rise

from the set point of Step 9. The maximum rise in outlet pressure on decreasing flow should not exceed the stated upper value of the range spring by greater than 10%. If it does, consult factory.

SECTION VI

VI. SHUTDOWN

1. Shutoff inlet block valve.
2. Allow sufficient time for the line pressure downstream of the inlet block valve to bleed down.
3. Shutoff the outlet block valve.
4. Relieve the trapped upstream and downstream pressure.
5. The regulator may now be removed from the pipeline or disassembled for inspection and preventative maintenance while in-line.

SECTION VII

VII. MAINTENANCE

A. General:

1. The regulator may be serviced without removing the regulator from pipeline. The regulator is designed with quick-change trim to simplify maintenance.
2. Record the nameplate information to requisition spare parts for the regulator. The information should include: size, Product Code, Serial Number, and internal or external sensing. (**NOTE: Never both types of sensing.**) If external sensing is used, be sure that the external sensing line is connected.
3. Refer to Section IX for recommended spare parts. Only use original equipment parts supplied by Cashco for rebuilding or repairing regulators.
4. Owner should refer to owner's procedures for removal, handling, cleaning and disposal of nonreusable parts, i.e. gaskets, etc.
NOTE: On regulators originally supplied as Special Cleaning Option-55, -56, or -57, maintenance must include a level of cleanliness equal to Cashco cleaning standards of #S-1134, #S-1542, and #S-1589 respectively. Contact factory for details.
5. The Inner Trim is removed and replaced in the body (23) as an assemblage of parts. The Inner Trim Assembly, hereinafter called **ITA**, consists of the following parts:
A detailed view of the dynamic side seal parts is shown in Figure 1 on the next page.

Item No.	Dynamic Seal Type	Part Description
13	All	Guide Bearing/Piston
14	All	Static Stem Seal
14.1	All	Upper Static Stem Seal
14.2	All	Middle Static Stem Seal
14.3	All	Lower Static Stem Seal
15	All	Cage O-ring Seal
16	CW,PW	Wiper
17.1	CW,PW	Wiper Washer
17.2	OR,CP,PR	Camber Adjusting Washer *
17.3	UC	Seal Retainer
19	All	Cage
20	All	Valve Plug
21	All	Seat Ring
27	All	Dynamic Side Seal
27.1	CP,CW	TFE Cap Seal
27.2	CP, CW	O-ring Energizer/Seal
27.3	UC	U-Cup Seal w/Metal Energizer
27.4	OR	O-Ring Seal
27.5	PR,PW	Piston Ring Seal
27.6	PR,PW	Piston Ring SST Energizer

* Metal Diaphragm Only.

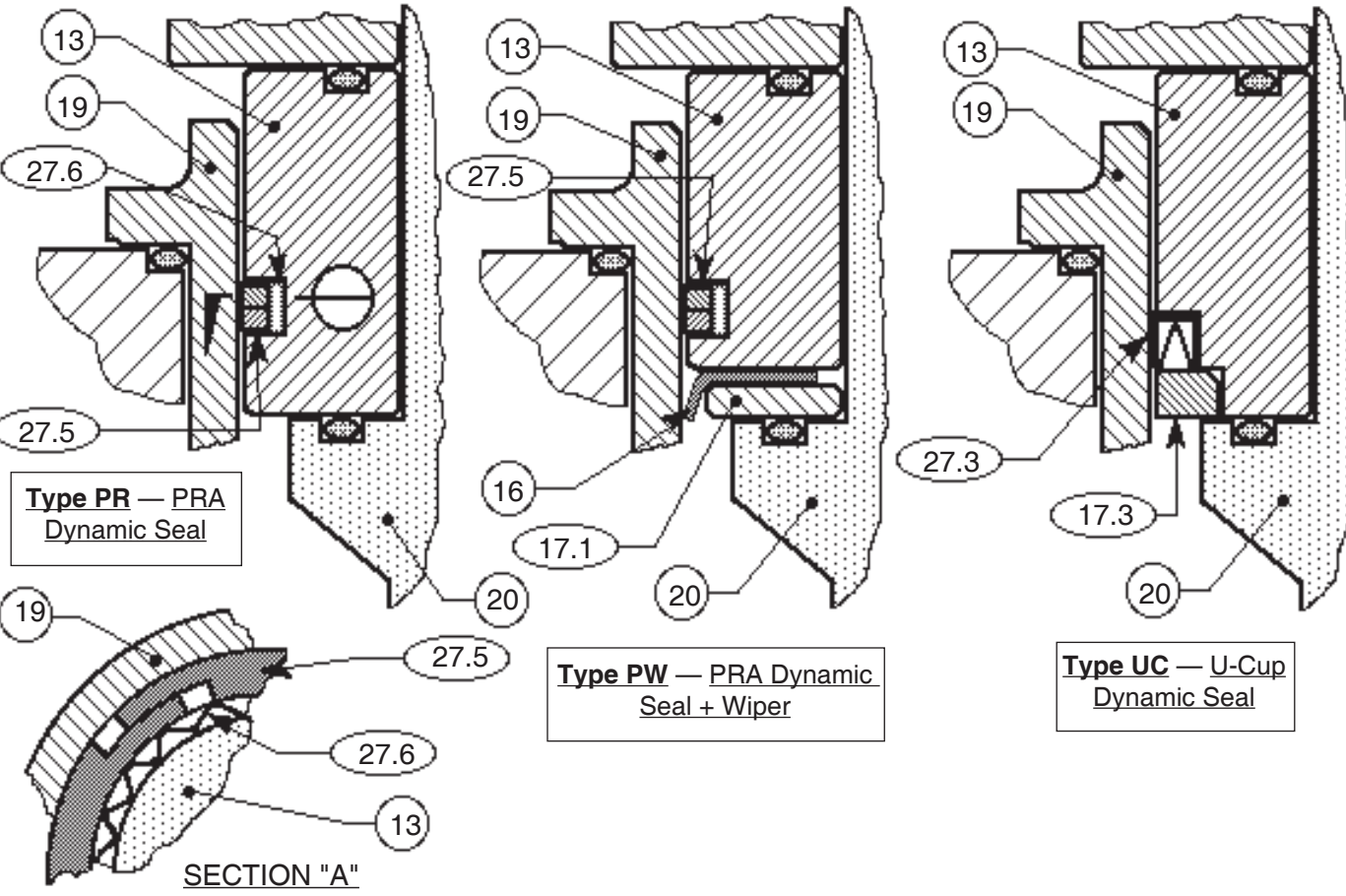
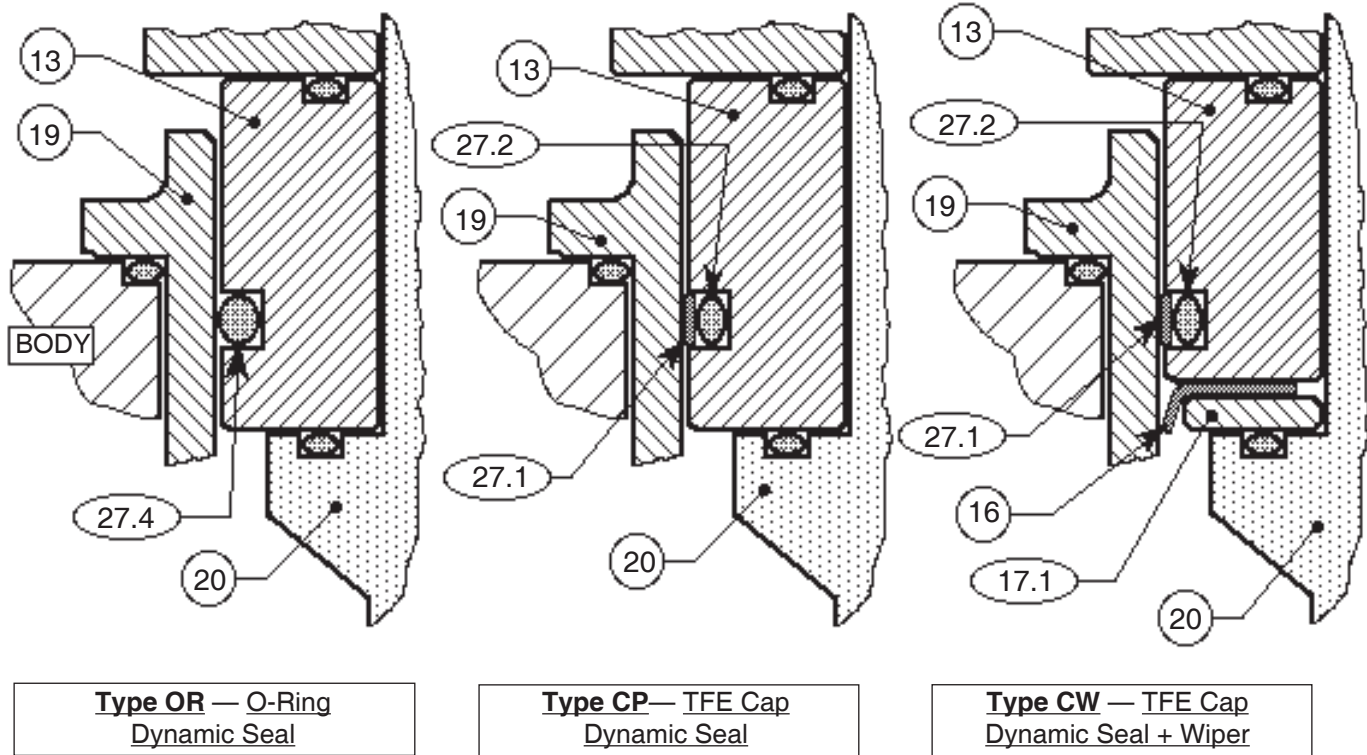

Figure 1: Dynamic Side Seals

B. Main Valve Disassembly:



WARNING

SYSTEM UNDER PRESSURE. Prior to performing any maintenance, isolate the regulator from the system and relieve all pressure. Failure to do so could result in personal injury.

1. Shut down the system in accordance with Section VI.
2. Disconnect the external sensing line, if installed.
3. Though it is possible to disassemble the valve unit while installed in a pipeline, it is recommended that maintenance be done in a shop when possible. The description thereafter will assume shop disassembly. Remove valve from pipeline.
4. Place the valve unit in a vise with the spring chamber (4) upwards.
5. Loosen adjusting screw lock nut (2) and relax range spring (6) forces by turning adjusting screw (1) CCW (viewed from above) until removed from spring chamber (4).
6. Loosen the diaphragm flange bolts (11) and nuts (12) uniformly.
7. Place matchmarks on body (23) and spring chamber (4) flanges. Remove the spring chamber (4).
8. Remove spring follower (5) and range spring (6).
9. For composition diaphragm construction, hold the milled "flats" on top of the valve plug (20) stationary with vise grips. Loosen and remove the diaphragm lock nut (7). **NOTE: Metal diaphragm constructions do NOT have a diaphragm lock nut (7).**
10. Remove upper diaphragm pressure plate (8).
11. Remove diaphragm(s) (9, 9.1, 9.2, 9.9) and o-ring upper stem seal (14.1). Examine diaphragm(s) to determine whether failed; determine if operating conditions are exceeding pressure, pressure drop or temperature limits.
12. For composition diaphragm construction, remove lower diaphragm pusher plate (10).

13. Evenly loosen the three cage cap screws (18) in single revolution increments. If the regulator contains a lower piston spring (22), the ITA should rise as the cage cap screws (18) are evenly backed out. A downwards holding force should be applied to the top of the piston-guide bearing (13) to prevent the ITA from popping up as the last threads of the cage cap screws (18) are backed out.
14. Remove the ITA by pulling up on the valve plug (20). Set ITA aside.
15. Remove the lower piston spring (22), as applicable, from within the body (23). **NOTE: Composition diaphragm constructions do not normally include a lower piston spring (22); all metal diaphragm constructions MUST include a lower piston spring (22).**
16. Remove o-ring cage seal (15).
17. If supplied, remove internal sensing drilled plug (32) using 5/32" (4 mm) Allen wrench.
18. Remove body (23) from vise. Clean all reusable metal parts according to owner's procedures. **NOTE: On regulators originally supplied as Special Cleaning Option-55, -56, or -57, maintenance must include a level of cleanliness equal to Cashco cleaning standards of #S-1134, #S-1542, #S-1589 respectively. Contact factory for details.**

C. Disassembly of the ITA:

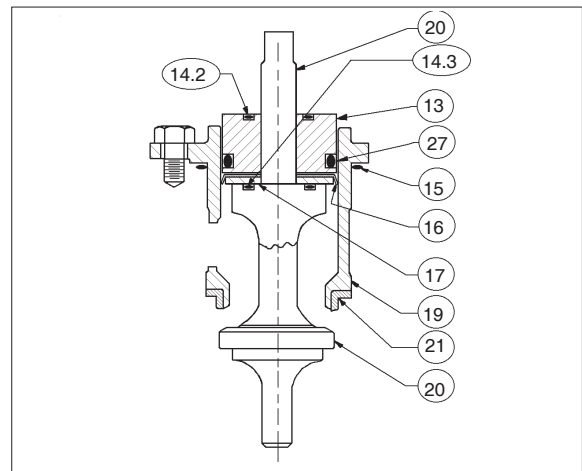

Figure 2: Assembled ITA, Composition Diaphragm Construction

1. Units with Composition Diaphragm(s) (See Figure 2):
 - a. Pull the valve plug (20) downwards and out of the piston-guide bearing (13) and out of the cage's (19) bottom, while holding the cage (19).
 - b. Remove the piston-guide bearing (13) from the upper end of the cage (19).

- c. Remove o-ring middle stem seal (14.2) from piston-guide bearing (13).
- d. Examine the components (27.1, 27.2, 27.3, 27.4, 27.5, 27.6) of the dynamic side seal (27) mechanism to determine if significant leakage was occurring. If the dynamic side seal (27) shows signs of significant leakage, determine if operating conditions are exceeding pressure, pressure drop, or temperature limits.
Remove dynamic side seal (27) components. Special care should be taken when using "tools" to remove the components to ensure that no scratches are imparted to any portion of the piston-guide bearing (13) groove.
- e. Remove wiper seal (16), if supplied, from within cage (19).
- f. Remove wiper washer (17.1), camber adjusting washer (17.2), or seal retainer (17.3), if supplied, from within cage (19).
- g. Remove o-ring lower stem seal (14.3) from plug (20).
- h. Remove seat ring (21); examine for signs of leakage. If seat ring (21) shows signs of significant leakage, determine if operating conditions of pressure, pressure drop, or temperature are exceeding limits.

2. Units with Metal Diaphragm(s) (See Figure 3):

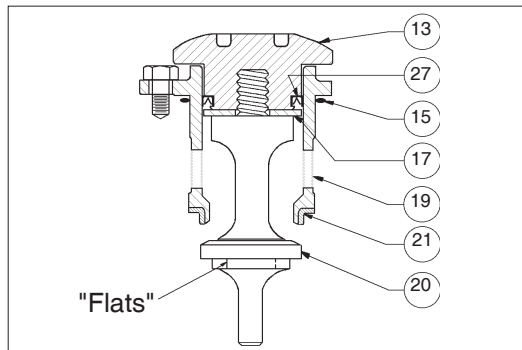

Figure 3: Assembled ITA,
Metal Diaphragm Construction

- a. To disassemble the ITA, hold the lower part of the valve plug (20) in a bench vise, grasping on "flats" directly under seat disc portion of plug (20). Do not hold on the machined surface in the plug's (20) spindle area. (The spindle "slides" in the pressed-in-place lower guide bushing (24) and can not be allowed to be marred.)
- b. Using a special double-posted spanner wrench fitting (to order see NOTE in Section IX, Parts Ordering Information), turn the piston-guide bearing (13) CCW to loosen; piston-guide bearing (13) can be removed by hand after loosening.

- c. Pull the valve plug (20) downwards and out of the piston-guide bearing (13) and out of the cage's (19) bottom while holding the cage (19).
- d. Remove the piston-guide bearing (13) from the upper end of cage (19).
- e. Examine the components (27.1, 27.2, 27.3, 27.4, 27.5, 27.6) of the dynamic side seal (27) mechanism to determine if significant leakage was occurring. If the dynamic side seal (27) shows signs of significant leakage, determine if operating conditions are exceeding pressure, pressure drop, or temperature limits.

Remove dynamic side seal (27) components and discard. Special care should be taken when using "tools" to remove the components to ensure that no scratches are imparted to any portion of the piston-guide bearing (13) groove.

- f. Remove wiper seal (16), if supplied, from within cage (19).
- g. Remove wiper washer (17.1) or camber adjusting washer (17.2), if supplied, from within cage (19).
- h. Remove o-ring lower stem seal (14.3) from plug (20).
- i. Remove seat ring (21); examine for signs of leakage. If seat ring (21) shows signs of significant leakage, determine if operating conditions of pressure, pressure drop, or temperature are exceeding limits.

- 3. Clean all reusable metal parts according to owner's procedures. **NOTE:** *On regulators originally supplied as Special Cleaning Option-55, -56, or -57, maintenance must include a level of cleanliness equal to Cashco cleaning standards of #S-1134, #S-1542, #S-1589 respectively. Contact factory for details.*

D. Inspection of Parts:

- 1. After inspection remove from the work area and discard the old "soft goods" parts (i.e. o-rings, diaphragms, seals, gaskets, etc.) after inspection. These parts **MUST** be replaced with factory supplied new parts.
- 2. Inspect the metal parts that will be reused. The parts should be free of surface contaminants, burrs, oxides, and scale. Rework and clean the parts as necessary. Surface conditions that affect the regulator performance are stated below; replace parts that can not be reworked or cleaned.

3. QC Requirements:
 - a. Valve plug (20);
 1. 16 rms finish on its seating surface for tight shutoff.
 2. No major defects on bottom guide spindle.
 - b. Cage (19);
 1. 16 rms finish on cylinder bore. No “ledges” formed due to wear from moving dynamic side seal (27) or wiper seal (16).
 - c. Lower guide bushing (24) (non-replaceable):
 1. 16 rms finish on bore.
 2. Max 0.015 inch (0.38 mm) clearance between valve plug (20) spindle and lower guide bushing (24).
 - d. Internal sensing drilled plug (32);
 1. Ensure that bore is minimum 0.125 inch (3.20 mm). Drill out as required.
4. Staging Material for Reassembly.
 - a. Inspect and clean parts, as necessary, from the spare parts kit. (See Article VI.A.4. comments concerning cleaning for oxygen service.)
 - b. Lay out all the regulator parts and check against the bill of material.

2. For metal diaphragm construction, insert camber adjusting washer (17.2) into cage (19) and allow to rest in the bottom of the cage (19).
3. Position piston-guide bearing (13) over upper end of cage (19) properly oriented. Using thumbs, evenly press piston-guide bearing (13) into the cage (19), ensuring not to “cut” o-ring seal (27.4). Continue pressing piston-guide bearing (13) until in approximate final position.

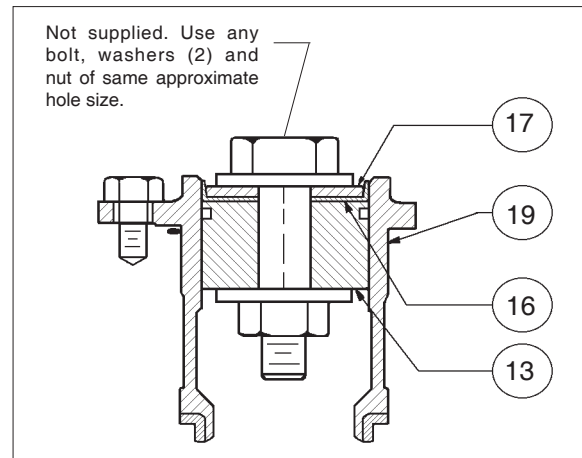

Figure 4

E. Reassembly of the ITA:

1. When replacing the optional wiper seal (16), the replacement wiper seal (16) is “pre-formed”. It will, however, require reforming. Reform the wiper seal (16) by pressing the temporary assembly parts into the cage (19) backwards as shown in Figure 4. The wiper seal (16) is best left in this position overnight, but a minimum of two (2) hours prior to reassembly.
2. After forming the wiper seal, remove parts (13, 16, 17) from cage (19) and disassemble the temporary assembly of Step 1. above.
3. Installation of dynamic side seal (27) (See Figure 1):
 - a. Type OR:
 1. Stretch o-ring seal (27.4) over lower circumference of piston-guide bearing (13), taking care not to “cut” o-ring seal (27.4). Using thumbs, work the o-ring seal (27.4) up and into the groove of the piston-guide bearing (13). **NOTE: A very slight amount of fluid and elastomer compatible lubricant is recommended as an installation aid.**

b. Type CP:

1. Stretch o-ring energizer/seal (27.2) over lower circumference of piston-guide bearing (13), taking care not to “cut” o-ring energizer/seal (27.4). Using thumbs, work the o-ring energizer/seal (27.4) up and into the groove of the piston-guide bearing (13). **NOTE: A very slight amount of fluid and elastomer compatible lubricant is recommended as an installation aid.**
2. For metal diaphragm construction, insert camber adjusting washer (17.2) into cage (19) and allow to rest in the bottom of the cage (19).
3. Position TFE cap seal (27.1) ring with rectangular cross-section at end of piston-guide bearing (13). Stretch cap seal (27.1) over lower end of piston-guide bearing (13) using thumbs to work the cap seal (27.1) onto the piston-guide bearing (13). **DO NOT USE A TOOL FOR THIS STEP.** Continue pressing cap seal (27.1) upwards towards the groove until the cap seal (27.1) “snaps” into the groove of the piston-guide bearing (13).

4. Position piston-guide bearing (13) over and into upper end of cage (19) until the cap seal (27.1) edge touches the upper lip of the cage (19). While gently applying force to press the piston-guide bushing (13) into the cage (19), simultaneously use fingers to lightly press the cap seal (27.1) inwards into the groove of the piston-guide bearing (13) until the cap seal (27.1) “slips into” the cage (19). **DO NOT USE TOOLS, LUBRICANT, OR HEAVY FORCE TO ENGAGE THE CAP SEAL (27.1) INTO THE CAGE (19).** Do not press inwards on the Cap Seal (27.1) too much or the cap seal (27.1) may slide out of its groove or the cap seal (27.1) can be damaged.
- c. Type CW:
1. Stretch o-ring energizer/seal (27.2) over lower circumference of piston-guide bearing (13), taking care not to “cut” o-ring energizer/seal (27.4). Using thumbs, work the o-ring energizer/seal (27.4) up and into the groove of the piston-guide bearing (13). **NOTE:** A very slight amount of fluid and elastomer compatible lubricant is recommended as an installation aid.
 2. Place wiper washer (17.1) into “cup” of Wiper Seal (16). Holding these parts (17.1 & 16) between thumb and forefinger, insert into cage (19) at an approximate 45° angled approach with wiper washer (17.1) on bottom, wiper seal (16) on top with turned-down lip of wiper seal (16) entering cage (19) first. Rotate wiper seal (16) and wiper washer (17.1) to a level position approximately half way down into cage (19). Allow wiper washer (17.1) to rest on bottom of cage (19).
 3. Position TFE cap seal (27.1) ring with rectangular cross-section at end of piston-guide bearing (13). Stretch cap seal (27.1) over lower end of piston-guide bearing (13) using thumbs to work the cap seal (27.1) onto the piston-guide bearing (13). **DO NOT USE A TOOL FOR THIS STEP.** Continue pressing cap seal (27.1) upwards towards the groove until the cap seal (27.1) “snaps” into the groove of the piston-guide bearing (13).
- d. Type PR:
1. Stretch corrugated metal piston ring energizer (27.6) over lower circumference of piston-guide bearing (13). Using thumbs work the energizer (27.6) into the piston-guide bearing (13) groove.
 2. Spread a piston ring seal (27.5) and slide over lower circumference of piston-guide bearing (13), taking care not to “cut” piston ring seal (27.5). Using thumbs, work the piston ring seal (27.5) into the groove of the piston-guide bearing (13). Repeat this procedure with a second piston ring seal (27.5). **NOTE:** *A piston ring assembly (PRA) consists of one metal corrugated energizer (27.6) and two piston ring seals (27.5). Also, the 6" body size includes three sets of PRA's in the sets of grooves; all other body sizes have only one set of PRA.*
 3. Position piston-guide bearing (13) over and into upper end of cage (19) until the lower piston ring seal (27.5) touches the upper lip of the cage (19). While gently applying force to press the piston-guide bearing (13) into the cage (19), simultaneously use fingers to lightly circumferentially press the first (lower) piston ring seal (27.5) inwards into the piston-guide bearing (13) groove until the first piston ring seal (27.5) “slips into” the cage (19). Repeat for the second piston ring seal (27.5).

e. Type PW:

1. Place wiper washer (17.1) into “cup” of Wiper Seal (16). Holding these parts (17.1 & 16) between thumb and forefinger, insert into cage (19) at an approximate 45° angled approach with wiper washer (17.1) on bottom, wiper seal (16) on top with turned-down lip of wiper seal (16) entering cage (19) first. Rotate wiper seal (16) and wiper washer (17.1) to a level position approximately half way down into cage (19). Allow wiper washer (17.1) to rest on bottom of cage (19).
2. Stretch corrugated metal piston ring energizer (27.6) over lower circumference of piston-guide bearing (13). Using thumbs work the energizer (27.6) into the piston-guide bearing (13) groove.
3. Spread a piston ring seal (27.5) and slide over lower circumference of piston-guide bearing (13), taking care not to “cut” piston ring seal (27.5). Using thumbs, work the piston ring seal (27.5) into the groove of the piston-guide bearing (13). Repeat this procedure with a second piston ring seal (27.5). **NOTE:** A piston ring assembly (PRA) consists of one metal corrugated energizer (27.6) and two piston ring seals (27.5).
4. Position piston-guide bearing (13) over and into upper end of cage (19) until the lower piston ring seal (27.5) touches the upper lip of the cage (19). While gently applying force to press the piston-guide bearing (13) into the cage (19), simultaneously use fingers to lightly circumferentially press the first (lower) piston ring seal (27.5) inwards into the piston-guide bearing (13) groove until the first piston ring seal (27.5) “slips into” the cage (19). Repeat for the second piston ring seal (27.5).

f. Type UC:

1. Position u-cup seal (27.3) over lower circumference of piston-guide bearing (13). Ensure that the u-cup seal (27.3) is oriented with the center-open-downwards as shown in Figure 1, as the u-cup seal (27.3) depends upon the P1-Inlet Pressure to pressure activate the seal for proper sealing action.
2. Position piston-guide bearing (13) over and into upper end of cage (19)

until the cap seal (27.1) edge touches the upper lip of the cage (19). While gently applying force to press the piston-guide bearing (13) into the cage (19), simultaneously use fingers to lightly press the u-cup seal (27.3) inwards into the groove of the piston-guide bearing (13) until the u-cup seal (27.3) “slips into” the cage (19). **DO NOT USE TOOLS, LUBRICANT, OR HEAVY FORCE TO ENGAGE THE U-CUP SEAL (27.3) INTO THE CAGE (19).**

4. Place properly oriented seat ring (21) onto its shoulder at the lower end of cage (19).
5. Composition Diaphragm Designs.
 - a. Place new o-ring lower stem seal (14.3) into groove of valve plug (20).
 - b. Insert valve plug (20) upwards through lower end of cage (19) and through the center hole in piston-guide bearing (13), also capturing camber adjusting washer (17.2), wiper washer (17.1) and wiper seal (16), if supplied. Hold plug (20) and cage (19) together.
 - c. Place an oversized nut or stack of washers, the same approximate height of the upper diaphragm pressure plate (8) and the lower diaphragm pusher plate (10), over the upper end of valve plug (20) and temporarily secure with diaphragm lock nut (7), manually tightened. **DO NOT ALLOW PLUG (20) TO ROTATE AGAINST SEAT RING (21) DURING TIGHTENING.**
 - d. This completes ITA preliminary/partial reassembly.
6. Metal Diaphragm Designs.
 - a. Insert valve plug (20) upwards through lower end of cage (19) and through the center hole of camber adjusting washer (17.2) or wiper washer (17.1) and wiper seal (16).
 - b. Engage valve plug (20) with piston-guide bearing (13) threads and tighten manually as far as possible.
 - c. Place ITA into a vise with leaded jaws and grasp at a hub location on the valve plug (20) that is not in the “spindle” zone. (See Figure 3.)
 - d. Using a special double-posted spanner wrench fitting (to order see NOTE in Section IX, Parts Ordering Information), tighten the piston-guide bearing (13) to the valve plug (20) with the following torque values. **DO NOT ALLOW PLUG (20) TO ROTATE AGAINST SEAT RING (21)**

DURING TIGHTENING.

Recommended Torque Values are:			
Body Size		Torque	
in.	(mm)	ft-lbs	(Nm)
1/2"-1"	(DN15-25)	30-50	(41-68)
1 1/4"-2"	(DN32-50)	45-70	(61-95)

e. This completes ITA reassembly.

F. Main Reassembly:

1. Place body (23) in a vise.
2. Reinstall internal sensing drilled plug (32) with compatible thread sealant.
3. Insert the lower piston spring (22) into the body (23), if supplied.
4. Fit the o-ring cage seal (15) into its body (23) groove.
5. With the ITA held manually in the closed position, insert ITA into body (23).
6. Properly align all three cage bolt (18) holes as there is only one circumferential location possible for this alignment. If a lower piston spring (22) is used, apply downward force to the top of the cage (19) until the ITA is lowered sufficiently to engage the cage bolts (18) into the body (23). Engage all of the cage bolts (18), then evenly screw in the cage bolts in one-half revolution increments to pull down the ITA, taking care NOT TO "COCK" THE ITA IN THE BODY. Torque the cage bolts (18) to 13-15 ft-lbs (18-20 N-m).
7. Composition Diaphragm Designs:
 - a. For the following steps b.–h., the upper end of valve plug (20) **MUST** be manually held up if unit is not supplied with lower piston spring (22).
 - b. Remove temporarily installed diaphragm lock nut (7) and spacers of previous Step 5.c. this section.
 - c. Place new o-ring middle stem seal (14.2) into groove of piston-guide bearing (13) upper surface.
 - d. Position lower diaphragm pusher plate (10) over upper end of valve plug (20) with tongue and groove on upper side.
 - e. Place new o-ring upper stem seal (14.1) over upper end of valve plug (20).
 - f. Place diaphragm(s) (9) over end of valve plug (20). NOTE: For multiple diaphragms (9) that include TFE material, the TFE should be on wetted side; for 6-ply TFE elastomer diaphragm (9), stackup is TFE-

- g. TFE-HK-HK-TFE-TFE, beginning with lower wetted diaphragm (9) first.
- g. Place upper diaphragm pressure plate (8) over upper end of valve plug (20) with tongue and groove "ridge" on lower side.
- h. Place lubricant on valve plug (20) threaded end. Engage diaphragm lock nut (7) with upper end of valve stem (20) as far as possible manually.
- i. Place a wrench on diaphragm lock nut (7) and a torque wrench on the upper end of valve plug (20). Hold torque wrench stationary and rotate diaphragm lock nut (7) to the following torque values:

Body Size		Torque	
in	(mm)	ft-lbs.	(Nm)
1/2"-1"	(DN15-25)	60-70	(81-95)
1 1/4"- 2"	(DN32-50)	120-130	(163-176)
2 1/2" - 4"	(DN65-100)	180-200	(244-271)

DO NOT allow valve plug (20) to rotate against seat ring (21) during tightening.

- j. This completes ITA reassembly.
8. Units with V-TFE & CTFE seat ring (21): Due to the relative "hardness" of the V-TFE & CTFE material, to obtain the best possible shutoff it is necessary to "coin" the V-TFE & CTFE with a permanent indentation.
 - a. Close-off the outlet connection.
 - b. The level of seat leakage can be quantified at the internal sensing drilled plug (32) for internal sensing units. For external sensing units, it will be necessary to remove the internal sensing plug (33).
 - c. Place 50 psig (3.5 Barg) of gas pressure to the valve's inlet.
 - d. Using a soft-headed mallet (rubber, leather), sharply rap the top end of the plug (20) for composition diaphragm designs, or the piston-guide bearing (13) for metal diaphragm designs. (Note: Gas will escape as the plug (20) opens at the seat ring (21). Allow sufficient time for leakage pressure on outlet to bleed-off.) The hammer rap should be strong enough to "bounce" the plug (20) into the seat ring (21), leaving the "coined" indentation.
 - e. Repeat d. a minimum of 2 times until the best possible seat leakage is obtained.
 - f. After "coining" completed, remove gas pressure source, remove outlet closure, and reinstall plug (33) if removed.
9. Metal Diaphragm Designs:
 - a. Install new diaphragm gasket (37) onto body (23) diaphragm flange.
 - b. Position diaphragm(s) (9) onto body's (23) diaphragm flange with bolt holes aligned.

- c. Position upper diaphragm pressure plate (8) onto center top of diaphragm(s) (9) with hub upwards.
10. Place a small amount of heavy grease into the adjusting screw (1) threaded opening of spring chamber (4). Reengage both adjusting screw (1) and its lock nut (2) with spring chamber (4). Allow end of adjusting screw to protrude into interior approximately 1/2 inch (12 mm).
 11. Place range spring (6) centered on upper diaphragm pressure plate (8).
 12. Place a dab of heavy grease in the recess of the spring follower (5). Place spring follower on upper end of range spring (6).
 13. Aligning matchmarks and bolt holes, place spring chamber (4) over range spring (6). If spring chamber (4) flange reaches body (23) flange without a gap, remove and lower adjusting screw (1) deeper into spring chamber (4) cavity another 1/4 inch. Repeat this procedure until the adjusting screw (1) keeps the two flanges from touching by approximately 1/8 inch (3 mm). **NOTE:** For metal diaphragm construction, if flanges do not come together equally, the upper diaphragm pressure plate (8) may be off-center. Remove spring chamber (4) and reposition upper diaphragm pressure plate (8) until the spring chamber (4) comes down evenly on all sides.
 14. Reinstall all flange bolts (11) and nuts (12) with nameplate (99) located under one bolt head. Hand-tighten nuts (12).

NOTE: If a six-ply diaphragm is being used, it is important that the diaphragm (9) is “preformed” – pulled together to remove as much entrapped air as possible and allow formation of a diaphragm (9) convolution. Starting with the body bolts and nuts (11,12) hand tightened, “preforming” can be accomplished by any one of the following techniques:

- a. Relax range spring fully by rotating adjusting screw CCW.
- b. Apply 30 psig (2.1 Barg) pressure to the valve outlet.

OR

Block the valve outlet and apply 30 psig (2.1 Barg) under the diaphragm through the 1/4" NPT (plugged) external pressure sensing connection on the valve diaphragm flange.

- c. Leave pressure on through tightening of bolting (11,12).
15. Evenly tighten the body bolting (11,12) in an

alternating cross pattern in one revolution increments to the following torque value:

Body Size		Torque	
in	(mm)	ft-lbs.	(Nm)
1/2"-2"	(DN15-50)	30-35	(41-47)
2 1/2"-4"	(DN65-100)	45-50	(61-69)

If supplied, remove pressure of previous Step 14.

G. Units with Supported Diaphragm Designs:

1. A supported diaphragm (9) construction is designated as Opt-80 High Outlet Pressure.
2. For a Model DA1 the only “special” part to be supplied is the spring chamber (4). This spring chamber (4) includes a machined ledge to support the diaphragm upon overpressure, and prevent a bust.

H. Converting Internal/External Sensing:

1. Disassemble the regulator and remove the diaphragm(s) (9) according to Steps 1-12 in Part B – Main Regulator Disassembly.
2. To convert from internal to external sensing, remove the drilled pipe plug (32) and install a solid pipe plug. Reverse this step for converting from external to internal sensing.
3. Reassemble the regulator according to Part F – Main Regulator Reassembly.

I. Pressure Testing:

1. If a hydrostatic pressure test is performed, pressure must be applied uniformly throughout the regulator. In particular apply the same pressure to body inlet, body outlet, and spring chamber.
DO NOT HYDROSTATICALLY TEST WITHOUT SPRING CHAMBER PRESSURIZED. NOT ADHERING WILL DO PHYSICAL INTERNALS DAMAGE THAT COULD RENDER THE UNIT INOPERABLE.
2. Inboard Leakage Test.
 - a. Release all range spring force by backing out adjusting screw fully.
 - b. Pressurize inlet to 30 psig (2.1 Barg) with air, GN₂.
 - c. Tube outlet to a beaker of water to observe number of escaping gas bubbles.
3. Pressure Containment Test.

- a. Pressurize inlet and outlet to 1.0 x Upper Value of Range Spring or 30 psig (2.1 Barg) with air or GN₂, whichever is higher.
- b. Soap solution test all external leak points; plugged connections, diaphragm flange, diaphragm bolting and spring chamber vent opening.

examination of sealing elements, correction of problem, reassembly and retesting. Leakage path may be via plug/seat or dynamic side seal.

4. Excessive leakage will require disassembly,

SECTION VIII

VIII. TROUBLE SHOOTING GUIDE

When trouble shooting this regulator there are many possibilities as to what may be causing problems. Many times, the regulator itself is not defective, but one or more of the accessories may be. Sometimes the process may be causing difficulties.

The key to efficient trouble shooting is information and communication. The customer should try to be as precise as possible in their explanation of the problem, as well as their understanding of the application and operating conditions.

It is imperative the following information be provided by the customer:

- Fluid (with fluid properties)
- Range of flow rate
- Range of inlet pressure
- Range of outlet pressure
- Range of fluid temperature
- Range of ambient temperature

Pressure readings should be taken at every location that pressure plays a role - i.e., regulator inlet (as close as possible to inlet port), regulator outlet (as close as possible to outlet port), etc.

Below are some of the more common complaints along with possible causes and remedies.

1. Erratic regulation, instability or hunting.

Possible Causes	Remedies
A. Sticking of internal parts	A. Remove internals, clean and if necessary, replace.
B. Load changes are too quick for system.	B. Convert to external sensing (if necessary) and install an orifice or needle valve in external sensing line.
C. Oversized regulator	C. Check actual flow conditions; resize regulator for minimum and maximum flow; if necessary, replace with smaller regulator.

2. Erratic regulation, instability or hunting (liquid service).

Possible Causes	Remedies
A. Air trapped under diaphragm.	A. Install valve on external sensing port and bleed off air. (Install regulator upside down to help prevent reoccurrence.)

3. Downstream pressure will not reach desired setting.

Possible Causes	Remedies
A. Supply pressure is down (confirm on pressure gauge.)	A. Increase supply pressure.
B. Undersized regulator.	B. Check actual flow conditions; resize regulator for minimum and maximum flow; if necessary, replace with larger regulator.

4. Diaphragm continually breaks (steam service regulators).

Possible Causes	Remedies
A. Stem seals (14) which protect fluorocarbon elastomer in diaphragm assembly may have deteriorated.	A. Replace with new stem seals (14).
B. Diaphragm nut (7) may not be torqued to proper value.	B. Confirm torque value in accordance with Section VI paragraph F-7.
C. Diaphragm too stiff causing it to crack in service.	C. Follow proper preforming and air evacuation techniques during diaphragm installation in accordance with Section VI, paragraph F-13.

5. Diaphragm continually breaks (all regulators).

Possible Causes	Remedies
A. Differential pressure across diaphragm may have exceeded limits. (See Table 4 in Tech Bulletin DA1-TB.)	A. Be aware of limits as well as where the various pressures are acting. Install pressure safety equipment as necessary.

6. Leakage at diaphragm flange.

Possible Causes	Remedies
A. Body bolts not torqued properly.	A. Torque to proper value (see Section VI, paragraph F-14)
B. Pressure at diaphragm may be too high for regulator design.	B. Consult factory.

7. Leakage across seat.

Possible Causes	Remedies
A. Contamination (debris) in regulator.	A1. Remove internals, clean, and if necessary, replace sealing and seating elements.* A2. "Coin" seat if V-TFE or CTFE seat material.
B. Oversized regulator; valve plug operates directly next to seat.	B. Check actual flow conditions; resize regulator for minimum and maximum flow; if necessary, replace with smaller regulator.

*Excess seat leakage may be diagnosed when a failure of the dynamic side seal has occurred. Inspect both potential internal leak paths.

SECTION IX

IX. ORDERING INFORMATION

NEW REPLACEMENT UNIT vs PARTS "KIT" FOR FIELD REPAIR

To obtain a quotation or place an order, please retrieve the Serial Number and Product Code that was stamped on the metal name plate and attached to the unit. This information can also be found on the Bill of Material ("BOM"), a parts list that was provided when unit was originally shipped. (Serial Number typically 6 digits). Product Code typical format as follows: (last digit is alpha character that reflects revision level for the product).

□□□□ - □□□□ 7 - □□□□□□□□□□

NEW REPLACEMENT UNIT:

Contact your local Cashco, Inc., Sales Representative with the Serial Number and Product code. With this information they can provide a quotation for a new unit including a complete description, price and availability.

If the "BOM" is not available, refer to the cross-sectional drawings included in this manual for part identification and selection.

A Local Sales Representative will provide quotation for appropriate Kit Number, Price and Availability.

CAUTION

Do not attempt to alter the original construction of any unit without assistance and approval from the factory. All purposed changes will require a new name plate with appropriate ratings and new product code to accommodate the recommended part(s) changes.

PARTS "KIT" for FIELD REPAIR:

Contact your local Cashco, Inc., Sales Representative with the Serial Number and Product code. Identify the parts and the quantity required to repair the unit from the "BOM" sheet that was provided when unit was originally shipped.

NOTE: *Those part numbers that have a quantity indicated under "Spare Parts" in column "A" reflect minimum parts required for inspection and rebuild, - "Soft Goods Kit". Those in column "B" include minimum trim replacement parts needed plus those "Soft Goods" parts from column "A".*

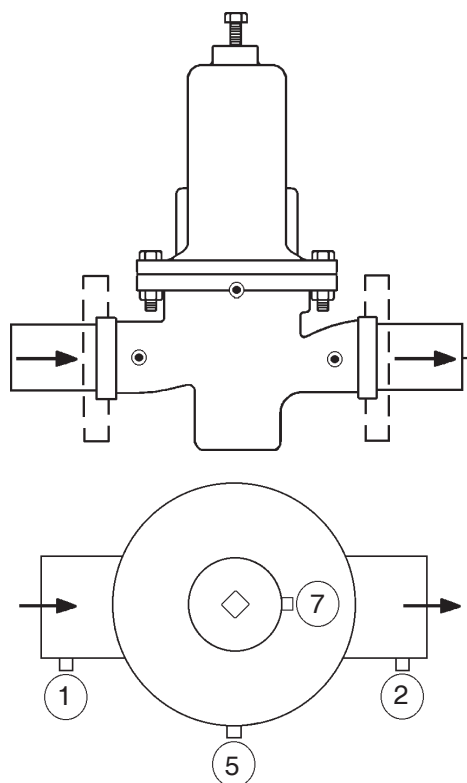
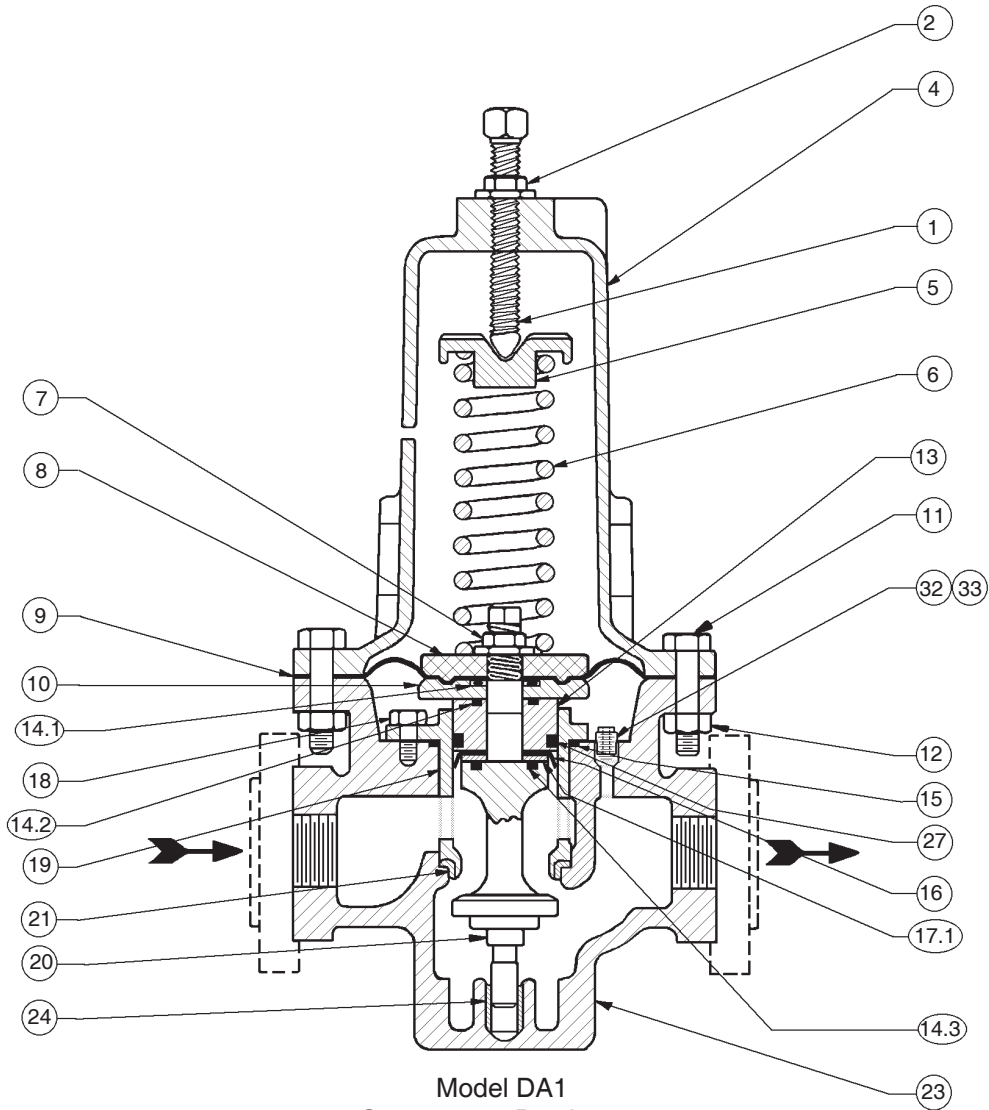

Figure 5: Location of Auxiliary Ports

The contents of this publication are presented for informational purposes only, and while every effort has been made to ensure their accuracy, they are not to be construed as warranties or guarantees, express or implied, regarding the products or services described herein or their use or applicability. We reserve the right to modify or improve the designs or specifications of such product at any time without notice. Cashco, Inc. does not assume responsibility for the selection, use or maintenance of any product. Responsibility for proper selection, use and maintenance of any Cashco, Inc. product remains solely with the purchaser.



Model DA1
Composition Diaphragm
(w/Wiper Seal)

Item No.	Description	Item No.	Description
1	Adjusting Screw	17.1	Wiper Washer
2	Adjusting Screw Lock Nut	18	Cage Cap Screws
4	Spring Chamber	19	Cage
5	Spring Follower (Button)	20	Valve Plug
6	Range Spring	21 ‡‡	Seat Ring
7	Diaphragm Lock Nut	22	Lower Piston Spring (if supplied)
8	Upper Diaphragm Pressure Plate	23	Body
9 ‡‡	Diaphragm	24	Lower Guide Bushing
9.1	Diaphragm (Material #1)	26	Tap Plug (Not Shown)
9.2	Diaphragm (Material #2)	** 27 ‡‡	Dynamic Side Seal
9.9	Diaphragm TFE Cover	27.1	TFE Cap Seal
10	Lower Diaphragm Pusher Plate	27.2	O-ring Energizer/Seal
11	Flange Bolts	27.3	U-cup with Metal Energizer
* 12	Flange Bolt Nuts	27.4	O-ring Seal
13	Piston-Guide Bearing	27.5	Piston Ring Seal
14 ‡‡	Stem Seals	27.6	Piston Ring Energizer
14.1	Upper Stem Seal	32	Internal Sensing Plug (External Sensing Only)
14.2	Middle Stem Seal	33	Internal Sensing Drilled Plug (Internal Sensing Only)
14.3	Lower Stem Seal		
15 ‡‡	Cage Seal		
16	Wiper Seal		

‡‡ Recommended Repair Parts

* Not required on 2" CS & SST Body Material.

** Reference Figure 1 for details of Item #27 - Dynamic Side Seal

Not Shown:

Item 66. Lays flat on top of item 8, only used when I.D. of spring, item 6, is too small to slip over item 7.



IOM ADDENDUM:

ATEX DIRECTIVE 2014/34/EU and THE EQUIPMENT AND PROTECTIVE SYSTEMS INTENDED FOR USE IN POTENTIALLY EXPLOSIVE ATMOSPHERES REGULATIONS 2016

Cashco, Inc. declares that the products listed in the table below has been found to comply with the Essential Health and Safety Requirements relating to the design and construction of products intended for use in potentially explosive atmospheres given in Annex II of the ATEX Directive 2014/34/EU and given in Schedule 1 of The Equipment and Protective Systems Indented for Use in Potentially Explosive Atmospheres Regulations 2016. Compliance with the Essential Health and Safety Requirements has been assured by compliance with EN ISO 80079-36:2016 and EN ISO 80079-37:2016. The product will be marked as follows:



The 'X' placed after the technical file number indicates that the product is subject to specific conditions of use as follows:

1. The maximum surface temperature depends entirely on the operating conditions and not the equipment itself. The combination of the maximum ambient and the maximum process medium temperature shall be used to determine the maximum surface temperature and corresponding temperature classification, considering the safety margins described prescribed in EN ISO 80079-36:2016, Clause 8.2. Additionally, the system designer and users must take precautions to prevent rapid system pressurization which may raise the surface temperature of system components and tubing due to adiabatic compression of the system gas. Furthermore, the Joule-Thomson effect may cause process gases to rise in temperature as they expand going through a regulator. This could raise the external surface temperature of the regulator body and the downstream piping creating a potential source of ignition. Whether the Joule-Thomson effect leads to heating or cooling of the process gas depends on the process gas and the inlet and outlet pressures. The system designer is responsible for determining whether the process gas temperature may raise under any operating conditions.
2. Where the process medium is a liquid or semi-solid material with a surface resistance in excess of $1G\Omega$, special precautions shall be taken to ensure the process does not generate electrostatic discharge.
3. Special consideration shall be made regarding the filtration of the process medium if there is a potential for the process medium to contain solid particles. Where particles are present, the process flow shall be $<1\text{m/s}$ ($<3.3\text{ft/s}$) in order to prevent friction between the process medium and internal surfaces.
4. Effective earthing (grounding) of the product shall be ensured during installation.
5. The valve body/housing shall be regularly cleaned to prevent build up of dust deposits.
6. Regulators must be ordered with the non-relieving option (instead of the self-relieving option) if the process gas they are to be used with is hazardous (flammable, toxic, etc.). The self-relieving option vents process gas through the regulator cap directly into the atmosphere while the non-relieving option does not. Using regulators with the self-relieving option in a flammable gas system could create an explosive atmosphere in the vicinity of the regulator.
7. Tied diaphragm regulators with outlet ranges greater than 7 barg (100 psig) should be preset to minimize the risk that improper operation might lead to an outboard leak and a potentially explosive atmosphere.
8. All equipment must only be fitted with manufacturer's original spare parts.
9. Ensure that only non-sparking tools are used, as per EN 1127-1, Annex A.

	PRODUCT
REGULATORS	31-B, 31-N
	1164, 1164(OPT-45)
	1171, 1171(OPT-45), 1171(CRYO)
	2171, 2171(OPT-45), 2171(CRYO), 3171
	1465, 3381, 3381(OPT-45), 3381(OPT-40)
	4381, 4381(OPT-37), 4381(CRYO), 4381(OPT-45), 5381
	MPRV-H, MPRV-L
	PBE, PBE-L, PBE-H
	CA-1, CA-2
	CA1, SA1, CA4, SA4, CA5, SA5
	DA2, DA4, DA5, DA6, DA8
	DA0, DA1, DAP, SAP
	SLR-1, SLR-2, PTR-1
	ALR-1, ULR-1, PGR-1
	BQ, BQ(OPT-45), BQ(CRYO)
	123, 123(CRYO), 123(OPT-45), 123(OPT-46G)
	123-1+6, 123-1+6(OPT-45), 123-1+6(OPT-46G), 123-1+6+S, 123-1+6+S(OPT-40)
	1000HP, 1000HP(OPT-37), 1000HP(OPT-45), 1000HP(OPT-45G), 1000HP(CRYO)
	1000HP-1+6, 1000HP-1+8, 1000LP, 1000LP(OPT-45), 1000LP(OPT-46G)
	6987
	8310HP, 8310HP-1+6, 8310HP-1+8, 8310LP, 8311HP, 8311LP
	345, 345(OPT-45)
	BA1/BL1, PA1/PL1
	C-BPV, C-PRV, C-CS
	D, D(CRYO), D(OPT-37), D(OPT-20), D(OPT-45)
	DL, DL(LCC), DL(OPT-45)
	BR, BR(CRYO)
	HP, HP(LCC), HP(OPT-45), HP(OPT46G), HP-1+6+S(OPT-40), HP-1+6+S
	P1, P2, P3, P4, P5, P7
	B2, B7
	POSR-1, POSR-2
5200P, 5300P	
135	
NW-PL, NW-SO	
CG-PILOT	
FG1	
CONTROL VALVES	RANGER, 987, PREMIER
	964, 521, 988, 988-MB, 989
	2296/2296HF
	SCV-30, SCV-S
TANK BLANKETING	8700, 8910, 8920, 8930, 8940
	2100, 2199
	3100, 3200, 3300, 3400, 3500, 3600, 3700
	1078, 1088, 1100, 1049
	5100, 5200, 5400, 5500
	4100, 4200, 4300, 4400, 4500, 4600
MISC	764P/PD, 764-37, 764T