

MODEL 1000HP - CRYOGENIC PRESSURE REDUCING REGULATOR

SECTION I

I. DESCRIPTION AND SCOPE

The Model 1000HP-5 and 1000HP-36 are cryogenic pressure reducing regulators used to control downstream (outlet or P_2) pressure to levels above 10 psig, and up to 300 psig (size dependent). Sizes are 1/2", 3/4", 1", 1-1/2" and 2".

The unit is designed for liquid or gaseous service with proper trim utilization, and proper jet selection.

Refer to Technical Bulletin 1000HP-CRYO-TB for sizing, application and selection recommendations.

Installation, operation and maintenance manuals (IOM's) exist for the following other Model 1000 products:

1000HP-Basic

1000LP-Basic

1000HP-Differential

SECTION II

II. INSTALLATION

1. An inlet block valve should always be installed.
2. If service application is continuous such that shutdown is not readily accomplished, it is recommended that an inlet block valve, and a manual bypass valve be installed.
3. Pipe unions must be installed to allow removal from piping. Trim can only be changed by unit removal from pipeline. If flanges are utilized, a lap joint flange is required on the inlet end of the valve to help align bolt holes as the cylinder screws into place.
4. An outlet pressure gauge should be located approximately ten pipe diameters downstream, and within sight.
5. All installations should include a downstream relief device if the inlet pressure could exceed the pressure rating of any downstream equipment or the maximum outlet pressure rating of the unit.

 **WARNING**

DO NOT HYDROSTATIC TEST THROUGH AN INSTALLED UNIT; ISOLATE REGULATOR FROM TEST. The upper range spring pressure level listed on the nameplate or 100 psig (6.9 Barg) minimum is the recommended "upper operative limit" for the sensing diaphragm (see Section IV. Startup, Number 7.) Higher pressures could cause internal damage. In addition, note on the nameplate that the Inlet and Outlet pressure and temperature ratings are at different levels.

6. Clean the piping of all foreign material including chips, welding scale, oil, grease and dirt before installing the valve. Strainers are recommended.

 **CAUTION**

Installation of adequate overpressure protection is recommended to protect the regulator from overpressure and all downstream equipment from damage in the event of regulator failure.

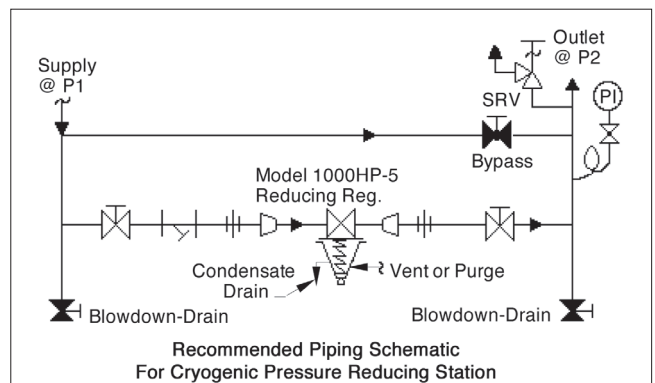

7. In placing thread sealant on pipe ends prior to engagement, ensure that excess material is removed and not allowed to enter the regulator upon startup.
8. Flow Direction: Install so the flow direction matches the arrow cast on the body.
9. For best performance, install in well drained horizontal pipe. Recommended position is with spring chamber vertically downwards. Orient to prevent the spring chamber vent hole from collecting rainwater or debris, and so drain hole can drip melted condensate as required. A purge gas is recommended for the spring chamber.
10. Regulators are not to be direct buried underground.
11. For insulated piping systems, recommendation is to not insulate regulator.
12. Cashco does not recommend field welding on the cylinder (inlet) end of the regulator, due to the possibility of warpage.

SECTION III

III. PRINCIPLE OF OPERATION

1. The Model 1000 is available in two variations: 1000LP (larger diaphragm) for downstream pressure control from 1-30 psig; 1000HP (smaller diaphragm) for downstream pressure control from 10-300 psig, body size dependent.
2. Movement occurs as pressure variations register on the diaphragm. The registering pressure is the outlet, P_2 , or downstream pressure. The range spring opposes diaphragm movement. As outlet pressure drops, the range spring pushes the diaphragm up, opening the port; as outlet pressure increases, the diaphragm pushes down and the port closes.
3. The Model 1000 includes a rocker arm in its operational mechanism. The rocker arm allows the regulator to operate flow-to-open (FTO), rather than conventional flow-to-close (FTC), which increases rangeability.
4. Due to the FTO design, there is a limit as to how low of a downstream (P_2 or outlet) pressure level setting is capable for a given inlet P_1 pressure. This is a function of the ratio of the port area to diaphragm area. It is possible for there to be too high of an inlet pressure for the regulator to close off against. (Refer to Technical Bulletin, Tables 6 and 7 for limits.) Reduced port, Option -12 allows lower downstream (P_2 or outlet) pressure settings for a given upstream (P_1 or inlet) pressure level.
5. The FTO design also is limited by a minimum pressure drop. If the regulator pressure drop is below 5 psi, an Option 1000-17 Piston Spring should be utilized to assist opening the valve piston. (Standard with 1000-5; must be specified with 1000-36.)
6. The Model 1000 includes an aspiration jet effect, due to the clearance of the piston from the body near the regulator's outlet. These clearances vary as to whether the fluid is a gas or a liquid. Jets must be selected to match one of these two general fluids. An improper jet selection will reduce performance.
7. A complete diaphragm failure will cause the regulator to fail open.

SECTION IV

IV. STARTUP

1. Purge the system, including the spring chamber, to remove air, moisture, carbon dioxide, etc.
2. Start with the block valves closed. A bypass valve may be used to maintain outlet pressure in the downstream system without changing the following steps.
3. Relax the range spring by turning the adjusting screw counterclockwise (CCW) a minimum of three (3) full revolutions. This reduces the outlet (downstream) pressure set point. **NOTE: Rotation CW or CCW is as viewed from the adjusting screw end, i.e. bottom of valve looking up.**
4. If equipped with a bypass valve, slowly open the bypass valve to cool the system piping and to allow slow contraction of the piping. Closely monitor outlet (downstream) pressure via gauge to ensure not over-pressurizing. **NOTE: If no bypass valve is installed, extra caution should be used in starting up an ambient temperature system; i.e. do everything slowly.**
5. Crack open the outlet (downstream) block valve.
6. Slowly open the inlet (upstream) block valve observing the outlet (downstream) pressure gauge. Determine if the regulator is flowing. If not, slowly rotate the regulator adjusting screw clockwise (CW) until flow begins.
7. Continue to slowly open the inlet (upstream) block valve until fully open.
8. Continue to slowly open the outlet (downstream) block valve, especially when the downstream piping system isn't pressurized. If the outlet (downstream) pressure exceeds the desired pressure, close the block valve and go to Step 2, then return to Step 4.
9. When flow is established steady enough that the outlet (downstream) block valve is fully open, begin to slowly close the bypass valve if installed.
10. Develop system flow to a level near its expected normal rate, and reset the regulator set point by turning the adjusting screw CW to increase outlet pressure, or CCW to reduce outlet pressure.
11. Reduce system flow to a minimum level and observe set point. Outlet pressure will rise from the set point of Step 9. The maximum rise in outlet pressure on decreasing flow should not exceed the stated upper limit of the range spring by greater than 30%; i.e. 10-40 psig range spring, at low flow the outlet pressure should not exceed 52 psig. If it does, consult factory.

SECTION V

V. SHUTDOWN

1. On systems with a bypass valve, and where system pressure is to be maintained as the regulator is shut down, slowly open the bypass valve while closing the inlet (upstream) block valve. Fully close the inlet (upstream) block valve. (When on bypass, the system pressure must be constantly observed and manually regulated.) Close the outlet (downstream) block valve.
2. If the regulator and system are to both be shutdown, slowly close the inlet (upstream) block valve. Close the outlet (downstream) valve only if regulator removal is required.



CAUTION

Do not walk away and leave a bypassed regulator unattended.

SECTION VI

VI. MAINTENANCE

A. General:

1. Maintenance procedures hereinafter are based upon removal of the regulator unit from the pipeline where installed.
2. Owner should refer to owner's procedures for removal, handling and cleaning of reusable parts, and disposal of nonreusable parts, i.e. asbestos gaskets, suitable solvents, etc.

3. If desired, gaskets may be oiled, or coated with gasket sealant or thread sealing compound, provided the sealant is compatible with the fluid. (See below for "oxygen cleaned" valves.)
4. Valves originally supplied as "oxygen cleaned" (Options 1000-55, 1000-5 or 1000-36) are assembled using special gasket sealant, Fluorolube GR-362¹, or equivalent. Cashco, Inc. recommends following factory cleaning specification #S-1134, or equivalent. Contact factory for details.

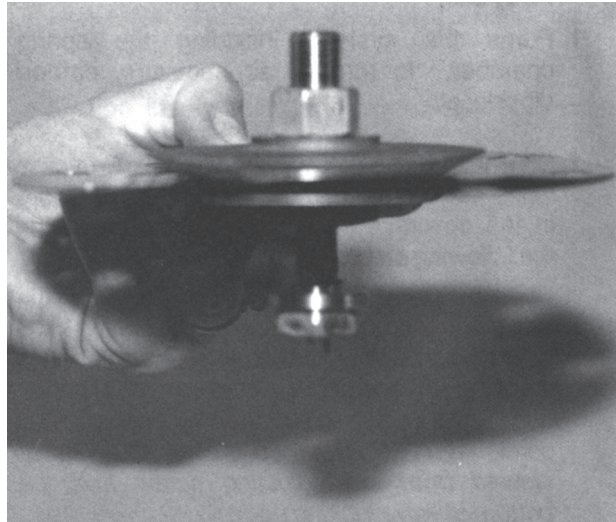

Diaphragm sub-assembly consists of items (10), (11), (12), (13), (15), (16) and (20).

B. Diaphragm Replacement:

1. Securely install the body (1) in a vise with the spring chamber (2) directed upwards.
2. Relax range spring (27) by turning adjusting screw (6) CCW until removed from spring chamber (2).
3. Paint or embed a match mark between body casting (1) and spring chamber casting (2) along flanged area.
4. Remove all diaphragm nuts (9) and bolts (8). Remove nameplate (28).
5. Remove spring chamber (2), range spring (27) and spring button (4).

NOTE: The text hereafter will refer to "pusher plate and stud (13)" as a single part, which it is for SST trim. Brass trim uses a separate "pusher plate (5)" and a "pusher plate stud (13)", both of which are peened together at initial assembly.

6. Pry up the diaphragm(s) (20) and diaphragm gasket (19) around the perimeter of the body (1) diaphragm flange to ensure that the diaphragm(s) (20) are not "sticking".
7. Remove the diaphragm sub-assembly by sliding the pusher plate and stud (13) and nut (11) in the direction of the regulator's inlet, approximately 1/2"-3/4". The pusher plate and stud (13), stud nut (10), and stud collar (16) should disengage with the rocker arm (14) slot. Lift vertically for the diaphragm sub-assembly removal.

8. Place the pusher plate stud (13) in a separate vise, gripping the stud (13) on the hexagonal cast-in-place edges located on the underneath side of the pusher plate stud. **NOTE:** Do not remove the stud nut (10), stud collar (16) and the location locking cotter pin (15). Loosen and remove nut (11).
9. Remove pressure plate (3) by lifting.
10. Pry loose pusher plate and stud (13) from diaphragm(s) (20) or from pusher plate gasket (12). Remove the diaphragm(s) (20).
11. Remove pusher plate gasket (12) from pusher plate and stud (13).
12. Clean gasket sealing surface of pusher plate and stud (13) thoroughly.
13. Install new pusher plate gasket (12), if required, over pusher plate and stud (13).
14. Install new diaphragm(s) (20) over pusher plate and stud (13). **NOTE:** Refer to the quantity of diaphragms (20) incorporated per the bill of materials listing. Depending on outlet pressure level, various quantities of metal diaphragms will be "stacked".

15. Inspect pressure plate (3) to ensure no deformation due to over-pressurization. If deformed, bent, or otherwise distorted, replace.
16. Ensuring that the curved outer rim side of the pressure plate (3) rests against the diaphragm (20) directly, place the pressure plate (3) over the pusher plate and stud (13). Place nut (11) onto the stud (13) and tighten to 35 ft.-lbs. torque for metal diaphragm. Use two flange bolts (8) to keep multiple diaphragms' (20) bolt holes properly aligned while tightening the stud nut (10). **(DO NOT USE FINGERS TO HOLD DIAPHRAGMS (20) DURING TIGHTENING OF NUT (11).)**
17. Remove cotter pin (15) securing stud nut (10) to lower end of pusher plate and stud (13), and replace with a new pin (15). (Do not allow the stud nut (10) to move when the cotter pin (15) is removed.)
18. Remove rocker arm shaft (17) and rocker arm (14). Measure inside of rocker arm (14) "prongs" as indicated below:
19. Check rocker arm shaft (17) for wear and straightness. Replace if damaged. Reinstall in body (1) through rocker arm (14). Apply thread sealant to the rocker arm shaft (17) threads prior to tightening. Make sure that the rocker arm shaft (17) enters the support slot opposite the threaded opening, and does not align crooked and restrained from full thread engagement of the rocker arm shaft (17). Make sure that the rocker arm (14) prongs that straddle the piston (24) hold the piston collar (23) against the piston (24); do not allow the rocker arm (14) prongs to push directly on the piston (24).
20. Clean the body (1) diaphragm flange. Sealant may be applied to the body (1) flange prior to diaphragm (20) placement. Install a new diaphragm gasket (19).
21. Using small gauge wire approximately 18" long, form a hook, and place the hook over one prong of the rocker arm (14), and rotate the rocker arm (14) up until slack is removed in the mechanism. Secure the wire through a body (1) flange bolt hole on the outlet side of the regulator.

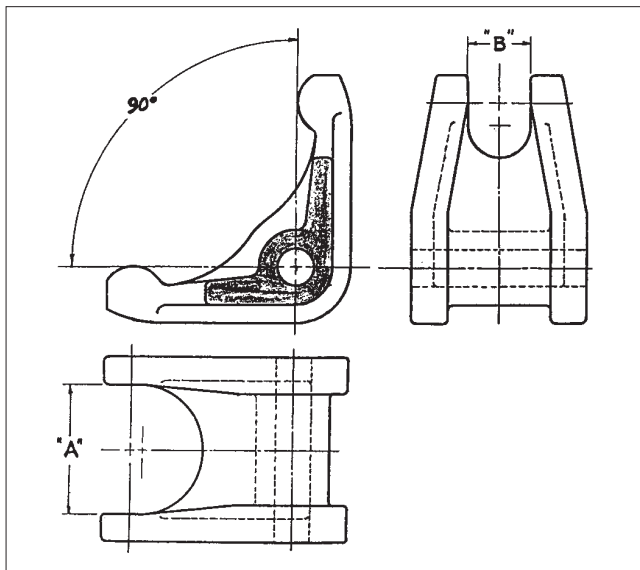

Dim.	Mat'l	Valve Size					
		1/2"	3/4"	1"	1-1/4"	1-1/2"	2"
A	BR	7/8"	1-5/32"	1-7/16"	1-13/16"	1-25/32"	2-3/16"
B	BR	5/8"	25/32"	3/4"	29/32"	7/8"	29/32"
A	SST	13/16"	1-1/16"	1-7/16"	1-1/2"	1-25/32"	2-5/32"
B	SST	9/16"	23/32"	3/4"	11/16"	7/8"	29/32"

If either of the above dimensions are exceeded by 1/8", replace rocker arm (14).

22. Take the diaphragm sub-assembly (Step 16) and lower it down into the body (1) cavity off-center approximately 3/4"-1" and towards the inlet side of the regulator. When fully lowered, slide the diaphragm sub-assembly horizontally towards the regulator's outlet. The wire of Step 21 should hold the rocker arm (14) up to allow engaging of the pusher plate and stud (13) (with stud nut (10) and stud collar (16)), so the rocker arm (14) prongs rest directly on the stud collar (16). **(Do not allow the rocker arm (14) prongs to get between the stud nut (10) and the stud collar (16).)** Pull firmly to remove wire holding rocker arm (14) up.
23. Align diaphragm (20) bolt holes with body (1) flange bolt holes. Set range spring (27) onto pressure plate (3), place spring button (4) on top of range spring (27). Place cryogenic, multi-purpose temperature lubricant into depression of spring button (4).

- Aligning the matchmarks, place spring chamber (2) over the above stacked parts. Install all bolts (8), nuts (9) and nameplate (28) by hand tightening. Tighten bolting (8 and 9) in a cross pattern that allows spring chamber (2) to be pulled down evenly. Recommended torques are as follows:

Model 1000HP-5 or -36		
Body Size	Bolt Size	Metal Diaph.
1/2"	3/8" Bolt	25 Ft/Lb
3/4"	7/16" Bolt	30 Ft/Lb
1"-1-1/4"	1/2" Bolt	35 Ft/Lb
1-1/2"	9/16" Bolt	45 Ft/Lb
2"	5/8" Bolt	45 Ft/Lb

- Reinstall adjusting screw (6) with locknut (7).
- Soap solution test around bolting (8 and 9), body (1), spring chamber (2) flanges, and cylinder (21)-to-body (1) joint for leakage. Ensure that an outlet pressure is maintained during this leak test of at least mid-range spring level; i.e. 10-40 psig range spring, 25 psig test pressure minimum. Use 100 psig minimum inlet pressure to leak test. Actual service conditions should be used if in excess of the minimum conditions.

C. Special Instructions for Diaphragm Removal:

- If Option 1000-9, TFE diaphragm cover, (35) is included, the diaphragm cover (35) should be placed on the wetted side of the lower diaphragm (20).
- Never replace bolting (8 and 9) with just any bolting if lost. Bolt heads and nuts are marked with specification identification numbers. Use only proper grades as replacements. Bolting is stainless steel.
- Use only factory provided gaskets; do not use "homemade" gaskets. Substitution may cause improper gasket compression. It may also adversely change diaphragm setting, which will affect unit's performance.
- Use only gaskets of the same material as those originally utilized.

D. Diaphragm Setting Adjustment:

- In the previous "Sub-Section B. Diaphragm Replacement", care was taken to prevent removal of the stud collar (16) and stud nut (10). Location of the stud nut (10) is a critical adjustment for a Model 1000 regulator.
- Not removing the stud nut (10) will provide performance equal to original factory performance when a diaphragm(s) (20) is replaced with a like diaphragm(s) (20). However, if the stud nut (10) is removed, or a switch is made from metal to composition diaphragm (20), or vice versa, the diaphragm setting should be checked.

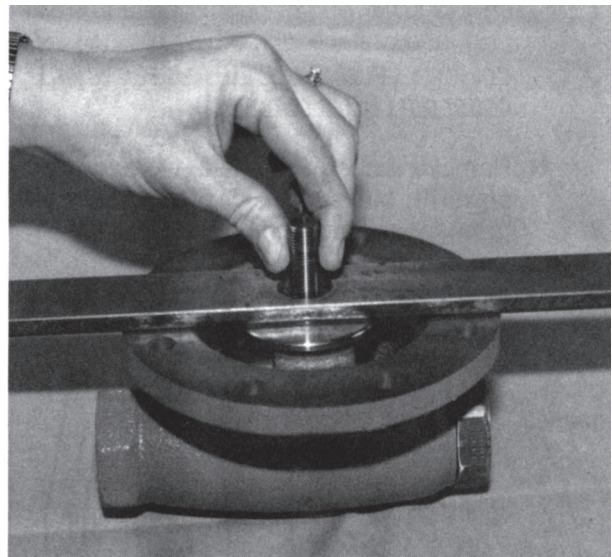

Checking diaphragm setting.

- Follow procedure "Sub-Section B. Diaphragm Replacement" at the point of removing diaphragm(s) (20), Step 14. Remove diaphragm gasket (19) and pusher plate stud gasket (12). Obtain a flat 12" x 1-1/2" x 1/4" plate bar with a 3/4" hole drilled in the center. Hook the pusher plate stud (13) into the rocker arm (14) prongs properly. Pull firmly up on the pusher plate stud (13) to ensure that all slack is removed from the mechanism and that the piston (24) is seated firmly. Relax the pulling and place the flat bar over the pusher plate stud (13) with the stud (13) passing through the hole of the bar. Again, pull firmly up to remove mechanism slack. One of three positions will be reached:

- a. Diaphragm setting too high. Pusher plate stud (13) will lift the flat bar over 0.020".
 - b. Diaphragm setting acceptable. Bar lifted between 0.010"-0.020".
 - c. Diaphragm setting too low. Bar lifted less than 0.010", or failed to be lifted.
4. The castle style stud nut (10) has six locations per revolution to align the stud nut (10) slots with the drilled hole through the pusher plate stud (13). Each stud nut (10) slot represents a movement up/down of 0.010". **NOTE:** *The ideal diaphragm setting is 0.015" high, and better performance is usually obtained when the diaphragm is slightly higher rather than lower. As the measuring of thousandths of an inch is difficult with such a procedure, it is recommended that the "null" position be found where the diaphragm (20) is flush with the body (1) flange (bar approximately at 0.000").* Remove the pusher plate stud (13), rotate the stud nut (10) one or two slots CCW to bring the setting to 0.015"-0.020" high.
 5. Place cotter pin (15) through the slot/hole, bend over ends.
 6. Continue re-assembly per Sub-Section B. Diaphragm Replacement, Step 14.

E. Trim Removal and Replacement:

1. Install body (1) horizontally in a vise with the spring chamber (2) directed upwards, and the body (1) held at the outlet end.
2. Use a box end wrench or socket, with a lever length of at least 24 inches, and place it over the hex surfaces of the cylinder (21). The wrench should be rapped with a hammer to loosen.
3. Continue to unscrew cylinder (21) until removed. The piston (24) and piston collar (23) should come out by gravity with the cylinder (21) removal.

4. If an Option 1000 -17 piston spring (30) is utilized, it also should be removed and replaced at trim replacement.
5. Inspect inside surface of cylinder (21) at four points:
 - a. Valve seat (21.2) ring erosion/wear on seating surfaces. If wear is excessive, consider utilizing Option 1000-15, stellited seat surfaces.
 - b. Valve seat (21.2) wire drawing between cylinder (21.1) and valve seat (21.2) where pressed in. If wear exists here, an Option 1000-14, integral seat, should be utilized as a replacement.
 - c. Flow induced wear at expansion zone where fluid turns to enter the piston (24) center.
 - d. Where the piston (24) ribbed guides bear (guide zone).

If wear is significant at any of these points, both cylinder sub-assembly (21) and piston sub-assembly (24 or 24, 25 and 26) should be replaced. (Cashco, Inc., does not recommend attempting to replace the valve seat (21.2) by pressing out and then re-pressing in. Cashco, Inc., also recommends that a cylinder (21) and piston (24 or 24, 25 and 26) be replaced as a set. Composition seat discs (25) may be replaced individually.)

⚠ CAUTION

Take precaution to not allow the piston (24) to fall from within the cylinder (21); tip cylinder with hex end down.

NOTE: *The Option 1000-17 piston spring and Option 1000-14 integral seat ring are standard with the Option 1000-5 construction.*

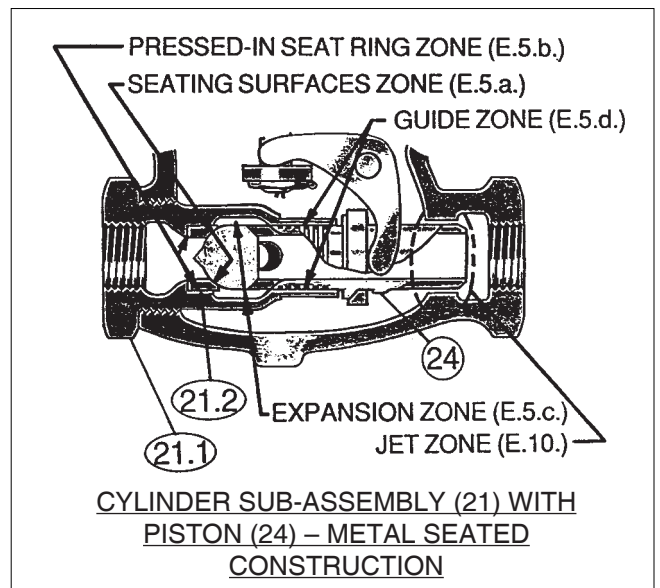

6. If a composition (soft) seat trim design is utilized, use the following sub-steps:
 - a. Tighten the "flats" of the seat disc screw (26) within a vise. Firmly hand-grip the piston (24) and turn CCW to loosen the seat disc screw (26). If too tight, place a screwdriver or similar rod within the piston (24) port holes and rotate. Remove the piston (24), and inspect for raised burrs around the port holes if a device is used to loosen; deburr as required. **NOTE: Do not grip the piston (24) with a wrench.**
 - b. Remove the seat disc (25) and clean the recessed piston (24) area where the seat disc (25) is placed. If the edges which form the recess of the piston (24) are worn, also replace piston (24) and seat disc screw (26).
 - c. Place seat disc (25) into recessed end of piston (24).
 - d. Place thread sealant on threaded portion of seat disc screw (26), and manually rotate piston (24) into seat disc screw (26) (still fixed in vise) to secure seat disc (25). Tighten seat disc screw (26) firmly. Do not over-tighten to the point of embedding the seat disc screw (26) into the seat disc (25); the seat disc (25) should lay flat with no rounded surface. A mechanical aid is normally not required; hand-tightening is normally sufficient.
7. If utilized, place piston spring (30) over smaller end of cylinder (21).
8. Insert piston assembly (24 metal seat; 24, 25 and 26 comp. seat) into end of cylinder (21).
9. Place piston collar (23) over end of piston (24), ensuring that the spherical surface of the piston (24) and the piston collar (23) bear against each other.
10. Clean the body (1) cavity through the openings. Clean the "jet area" just inside the body (1) outlet end through which the piston (24) projects. Clean all parts to be reused. **NOTE: On regulators originally supplied with Option 1000-55, "oxygen clean", maintenance must include a level of cleanliness equal to Cashco, Inc's., cleaning standard #S-1134. Contact factory for details.**
11. Use special care cleaning the flat mating surfaces of the body (1) and cylinder (21) shoulder, as this pressurized joint is metal-to-metal with no gasket.
12. Lubricate the cylinder (21) threads lightly with thread sealant. Insert the entire trim stack into the body (1) opening and screw until tightly seated. Using the hammer and wrench handle, impact the cylinder (21) into the body (1). **NOTES: 1. Take special precaution to keep piston collar from getting "cocked" at an angle when inserted. 2. On 2" brass bodies (1) with brass trim, a TFE body O-ring (43) is utilized to seal between the body (1) and the cylinder (21) sub-assembly. This O-ring is not indicated on the drawing.**
13. Inspect the body (1) outlet end to ensure that the piston (24) is located nearly concentric to the body (1) bore in the jet area with clearance. Under no conditions should the piston (24) be touching the body (1). Use two pencils or similar shafts to place in inlet and outlet ends of valve and alternately push on each end of the piston (24) to ensure free movement. (Total movement is approximately 1/8".)
14. Bench test unit for suitable operation and seat leakage. **NOTE: Regulators are not normally tight shutoff devices. Pressure must build above setpoint for best shutoff.**
15. Soap solution test around cylinder (21)-to-body (1) connection for leakage. Test pressure should be a minimum of 100 psig at the inlet, or actual service conditions if higher.

SECTION VII

VII. TROUBLE SHOOTING GUIDE

1. Erratic operation; chattering.

Possible Causes	Remedies
A. Oversized regulator; inadequate rangeability.	A1. Check actual flow conditions, resize regulator for minimum and maximum flow. A2. Increase flow rate. A3. Decrease regulator pressure drop; decrease inlet pressure by placing a throttling orifice in inlet piping union. A4. Replace full orifice with reduced orifice; i.e. new cylinder required.
B. Worn piston/cylinder; inadequate guiding.	B. Replace trim.
C. Flow induced instability.	C1. Get straight runs of piping (5 diameters upstream, 10 downstream) to and from valve. C2. Ensure outlet velocity is not excessive; use pipe reducer close to valve outlet. C3. Add next higher range spring.
D. Improper (oversized) jet.	D. Replace existing piston with new piston with proper jet.
E. Plugged trim.	E. Remove trim and check for plugged holes in piston, or debris in guide zone or jet zone.

2. Regulator outlet (downstream) pressure too low.

Possible Causes	Remedies
A. Setpoint too low.	A. Turn adjusting screw down (CW) to increase setpoint.
B. Regulator undersized.	B1. Confirm by opening bypass valve together with regulator. B2. Check actual flow conditions, resize and if regulator has inadequate capacity, replace with larger unit.
C. Plugged inlet strainer.	C. Remove strainer screen and clean; consider leaving screen out.
D. Plugged trim.	D. Remove trim and check for plugged holes in piston, or debris in guide zone or jet zone.
E. Incorrect range spring (turning adjusting screw CW does not allow bringing pressure level up to proper level).	E. Replace range spring with proper higher range.
F. Too much proportional band (droop).	F1. Review P.B. (droop) expected. (See 2.B1 above.) F2. Diaphragm setting too low; check and raise as required. F3. Improper jet; make sure jet matches actual fluid.
G. Restricted diaphragm movement. (pressure plate hitting upstops)	G1. Diaphragm setting too high; check and lower as required. G2. Ensure no moisture in spring chamber at temperatures below freeze point. Ensure no dust or debris entering vent opening. If rainwater or debris can enter, re-orient spring chamber.
H. Restricted diaphragm movement. (over-stretched diaphragm)	H1. Diaphragm setting too low; check and increase as required. H2. Ensure no moisture in spring chamber at temperatures below freeze point. Ensure no dust or debris entering vent opening. If rainwater or debris can enter, re-orient spring chamber. H3. Ensure drain opening is clear of blockage.

3. Leakage through the spring chamber vent hole.

Possible Causes	Remedies
A. Normal-life diaphragm failure.	A. Replace diaphragm.
B. Abnormal short-life diaphragm failure.	B1. Can be caused by excessive chattering. See No. 1 to remedy valve chatter. B2. Can be caused by corrosive action. Consider alternate diaphragm material, or Option 1000-9, TFE diaphragm cover. B3. Downstream (outlet) pressure buildup occurring that overstresses diaphragms.
C. Pusher plate gasket leaking.	C. Replace gasket.

4. Excessive pressure downstream.

Possible Causes	Remedies
A. Regulator not closing tightly.	<p>A1. Overly compressed range spring; i.e. approaching solid height. Use next higher range spring. Contact factory.</p> <p>A2. Inspect the seating. Clean and lap metal seat surfaces; replace if lapping does not remedy. If composition seats are depressed, nicked or embedded with debris, replace seat disc.</p> <p>A3. Diaphragm setting too high; check setting.</p> <p>A4. Inlet pressure too high for orifice size; check permissible inlet (P_1) pressure level for a given outlet. Change to reduced port if required. Leakage past pressed in valve seat ring; consider integral seat.</p> <p>A5. When diaphragm sub-assembly was put into place, the rocker arm got between the stud collar and the stud nut rather than on top of the stud collar.</p>
B. Downstream block.	B. Check system; isolate (block) flow at regulator inlet, not outlet. Relocate regulator if necessary.
C. No pressure relief protection.	C. Install safety relief valve, or rupture disc.
D. Restricted diaphragm movement.	<p>D1. Diaphragm setting too high; check and lower as required.</p> <p>D2. Ensure no moisture in spring chamber at temperatures below freeze point. Ensure no dust or debris entering vent opening. If rainwater or debris can enter, re-orient spring chamber.</p>

5. Sluggish operation.

Possible Causes	Remedies
A. Plugged spring chamber vent.	A. Clean vent opening.
B. Plugged piston or jet zone.	B. Remove trim and clean.
C. Plugged drain and vent opening.	C. Clear opening & purge.

6. Frequent resetting of setpoint.

Possible Causes	Remedies
<p>A. Over-pressurization downstream resulting in:</p> <ol style="list-style-type: none"> 1. Bent metal diaphragm(s). 2. Sprung rocker arm. 3. Range spring overstressed/fatigued. 	<p>A1. Replace diaphragms. Correct potential source of downstream over-pressure.</p> <p>A2. Check measurements of rocker arm. Replace if necessary.</p> <p>A3. Replace range spring; consider next higher range spring.</p>

SECTION VIII

VIII. ORDERING INFORMATION

NEW REPLACEMENT UNIT vs PARTS "KIT" FOR FIELD REPAIR

To obtain a quotation or place an order, please retrieve the Serial Number and Product Code that was stamped on the metal name plate and attached to the unit. This information can also be found on the Bill of Material ("BOM"), a parts list that was provided when unit was originally shipped. (Serial Number typically 6 digits). Product Code typical format as follows: (last digit is alpha character that reflects revision level for the product).

□□□□ - □□□□ 7 - □□□□□□□□□□□□

NEW REPLACEMENT UNIT:

Contact your local Cashco, Inc., Sales Representative with the Serial Number and Product code. With this information they can provide a quotation for a new unit including a complete description, price and availability.



CAUTION

Do not attempt to alter the original construction of any unit without assistance and approval from the factory. All purposed changes will require a new name plate with appropriate ratings and new product code to accommodate the recommended part(s) changes.

PARTS "KIT" for FIELD REPAIR:

Contact your local Cashco, Inc., Sales Representative with the Serial Number and Product code. Identify the parts and the quantity required to repair the unit from the "BOM" sheet that was provided when unit was originally shipped.

NOTE: *Those part numbers that have a quantity indicated under "Spare Parts" in column "A" reflect minimum parts required for inspection and rebuild, - "Soft Goods Kit". Those in column "B" include minimum trim replacement parts needed plus those "Soft Goods" parts from column "A".*

If the "BOM" is not available, refer to the cross-sectional drawings included in this manual for part identification and selection.

A Local Sales Representative will provide quotation for appropriate Kit Number, Price and Availability.

The contents of this publication are presented for informational purposes only, and while every effort has been made to ensure their accuracy, they are not to be construed as warranties or guarantees, express or implied, regarding the products or services described herein or their use or applicability. We reserve the right to modify or improve the designs or specifications of such product at any time without notice. Cashco, Inc. does not assume responsibility for the selection, use or maintenance of any product. Responsibility for proper selection, use and maintenance of any Cashco, Inc. product remains solely with the purchaser.



IOM ADDENDUM:

ATEX DIRECTIVE 2014/34/EU and THE EQUIPMENT AND PROTECTIVE SYSTEMS INTENDED FOR USE IN POTENTIALLY EXPLOSIVE ATMOSPHERES REGULATIONS 2016

Cashco, Inc. declares that the products listed in the table below has been found to comply with the Essential Health and Safety Requirements relating to the design and construction of products intended for use in potentially explosive atmospheres given in Annex II of the ATEX Directive 2014/34/EU and given in Schedule 1 of The Equipment and Protective Systems Intended for Use in Potentially Explosive Atmospheres Regulations 2016. Compliance with the Essential Health and Safety Requirements has been assured by compliance with EN ISO 80079-36:2016 and EN ISO 80079-37:2016. The product will be marked as follows:



The 'X' placed after the technical file number indicates that the product is subject to specific conditions of use as follows:

1. The maximum surface temperature depends entirely on the operating conditions and not the equipment itself. The combination of the maximum ambient and the maximum process medium temperature shall be used to determine the maximum surface temperature and corresponding temperature classification, considering the safety margins described prescribed in EN ISO 80079-36:2016, Clause 8.2. Additionally, the system designer and users must take precautions to prevent rapid system pressurization which may raise the surface temperature of system components and tubing due to adiabatic compression of the system gas. Furthermore, the Joule-Thomson effect may cause process gases to rise in temperature as they expand going through a regulator. This could raise the external surface temperature of the regulator body and the downstream piping creating a potential source of ignition. Whether the Joule-Thomson effect leads to heating or cooling of the process gas depends on the process gas and the inlet and outlet pressures. The system designer is responsible for determining whether the process gas temperature may raise under any operating conditions.
2. Where the process medium is a liquid or semi-solid material with a surface resistance in excess of $1G\Omega$, special precautions shall be taken to ensure the process does not generate electrostatic discharge.
3. Special consideration shall be made regarding the filtration of the process medium if there is a potential for the process medium to contain solid particles. Where particles are present, the process flow shall be $<1\text{m/s}$ ($<3.3\text{ft/s}$) in order to prevent friction between the process medium and internal surfaces.
4. Effective earthing (grounding) of the product shall be ensured during installation.
5. The valve body/housing shall be regularly cleaned to prevent build up of dust deposits.
6. Regulators must be ordered with the non-relieving option (instead of the self-relieving option) if the process gas they are to be used with is hazardous (flammable, toxic, etc.). The self-relieving option vents process gas through the regulator cap directly into the atmosphere while the non-relieving option does not. Using regulators with the self-relieving option in a flammable gas system could create an explosive atmosphere in the vicinity of the regulator.
7. Tied diaphragm regulators with outlet ranges greater than 7 barg (100 psig) should be preset to minimize the risk that improper operation might lead to an outboard leak and a potentially explosive atmosphere.
8. All equipment must only be fitted with manufacturer's original spare parts.
9. Ensure that only non-sparking tools are used, as per EN 1127-1, Annex A.

	PRODUCT
REGULATORS	31-B, 31-N
	1164, 1164(OPT-45)
	1171, 1171(OPT-45), 1171(CRYO)
	2171, 2171(OPT-45), 2171(CRYO), 3171
	1465, 3381, 3381(OPT-45), 3381(OPT-40)
	4381, 4381(OPT-37), 4381(CRYO), 4381(OPT-45), 5381
	MPRV-H, MPRV-L
	PBE, PBE-L, PBE-H
	CA-1, CA-2
	CA1, SA1, CA4, SA4, CA5, SA5
	DA2, DA4, DA5, DA6, DA8
	DA0, DA1, DAP, SAP
	SLR-1, SLR-2, PTR-1
	ALR-1, ULR-1, PGR-1
	BQ, BQ(OPT-45), BQ(CRYO)
	123, 123(CRYO), 123(OPT-45), 123(OPT-46G)
	123-1+6, 123-1+6(OPT-45), 123-1+6(OPT-46G), 123-1+6+S, 123-1+6+S(OPT-40)
	1000HP, 1000HP(OPT-37), 1000HP(OPT-45), 1000HP(OPT-45G), 1000HP(CRYO)
	1000HP-1+6, 1000HP-1+8, 1000LP, 1000LP(OPT-45), 1000LP(OPT-46G)
	6987
	8310HP, 8310HP-1+6, 8310HP-1+8, 8310LP, 8311HP, 8311LP
	345, 345(OPT-45)
	BA1/BL1, PA1/PL1
	C-BPV, C-PRV, C-CS
	D, D(CRYO), D(OPT-37), D(OPT-20), D(OPT-45)
	DL, DL(LCC), DL(OPT-45)
	BR, BR(CRYO)
	HP, HP(LCC), HP(OPT-45), HP(OPT46G), HP-1+6+S(OPT-40), HP-1+6+S
	P1, P2, P3, P4, P5, P7
	B2, B7
	POSR-1, POSR-2
	5200P, 5300P
135	
NW-PL, NW-SO	
CG-PILOT	
FG1	
CONTROL VALVES	RANGER, 987, PREMIER
	964, 521, 988, 988-MB, 989
	2296/2296HF
	SCV-30, SCV-S
TANK BLANKETING	8700, 8910, 8920, 8930, 8940
	2100, 2199
	3100, 3200, 3300, 3400, 3500, 3600, 3700
	1078, 1088, 1100, 1049
	5100, 5200, 5400, 5500
	4100, 4200, 4300, 4400, 4500, 4600
MISC	764P/PD, 764-37, 764T

