



ISO Registered Company



# RANGER QCT

## ROTARY CONTROL VALVE BODY ASSEMBLY

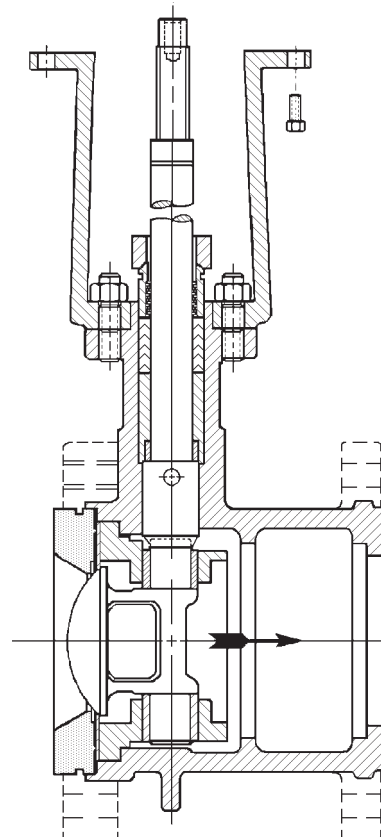
### FLANGED OR FLANGELESS DESIGN

#### SECTION I

##### I. DESCRIPTION AND SCOPE

This manual covers the body assembly of the Cashco Ranger QCT. Available sizes include 1", 1-1/2", 2", 3", 4", 6" and 8" (DN25, 40, 50, 80, 100, 150, 200). Flangeless DI bodies fit 150 and 300 lb. RF flanges. Flangeless CS and SST bodies, all sizes, fit 150, 300 and 600 lb. RF flanges. Integral flanged CS and SST bodies, sizes 1" through 3", mate with 150, 300 and 600 lb. RF flanges. Integral flanged CS and SST bodies, sizes 4", 6" and 8", mate with 150 and 300 lb. RF Flanges. All sizes of flangeless construction may be installed between PN40 flanges. Quick Change Trim (QCT) is furnished as a standard feature and allows use of several seal retainers and inserts to vary orifice size, help control cavitation and reduce noise. All trims use 90° plug rotation. Disassembly, inspection and reassembly of the trim can be accomplished easily without disturbing the packing, linkage or positioner calibration. Trim parts are self-centering.

Either of Cashco's pneumatically actuated actuators, Model 48 and Model 148, can be mounted to the Ranger QCT body.



#### SECTION II

##### II. REFERENCES

Refer to Technical Bulletin Ranger-TB for complete technical specifications coupled with either Cashco Actuator Model 48 or 148.

[www.cashco.com/techbulletins/ranger.pdf](http://www.cashco.com/techbulletins/ranger.pdf)

Refer to following Installation, Operation & Maintenance Manuals (IOM's) for either actuator and/or devices that maybe mounted to a Model Range body:

Actuators: [www.cashco.com/IOM/48.pdf](http://www.cashco.com/IOM/48.pdf)

[www.cashco.com/IOM/148.pdf](http://www.cashco.com/IOM/148.pdf)

Positioners:

P/P: [www.cashco.com/techbulletins/73.pdf](http://www.cashco.com/techbulletins/73.pdf)

P/P: [www.cashco.com/techbulletins/9540r.pdf](http://www.cashco.com/techbulletins/9540r.pdf)

I/P: [www.cashco.com/techbulletins/srd991.pdf](http://www.cashco.com/techbulletins/srd991.pdf)

I/P: [www.cashco.com/iom/PS2iom.pdf](http://www.cashco.com/iom/PS2iom.pdf)

##### ABBREVIATIONS

ATC-FO	– Air-to-Close, Fail Open
ATO-FC	– Air-to-Open, Fail Close
CCW	– Counter-Clockwise Rotation
CS	– Cast Carbon Steel
CW	– Clockwise Rotation
CWP	– Cold Working Pressure
DIR	– Direct Acting
DI	– Ductile Iron
IAS	– Instrument Air Supply
IOM	– Installation, Operation and Maintenance Manual
LOAD	– Positioner Output Air Pressure
REV	– Reverse Acting
RF	– Raised Face
SIG	– Output Signal from Instrument
SST	– Cast or Wrought 316 Stainless Steel
V	– Vent

## SECTION III

### III. INSTALLATION

#### A. Orientation:

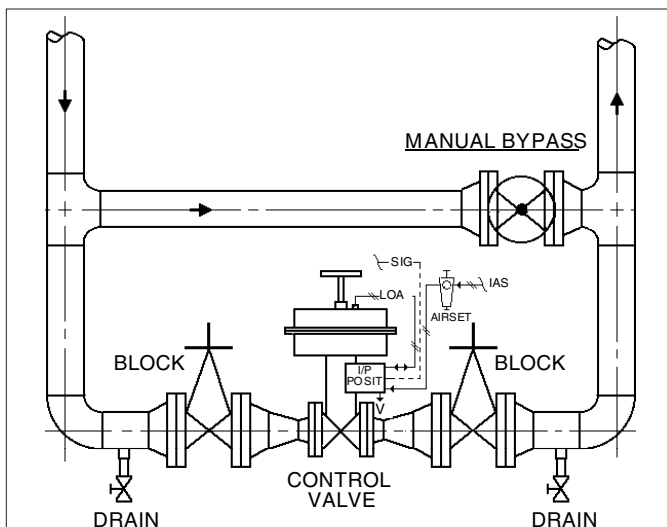
1. Preferred orientation when valve is installed in either a horizontal or vertical pipeline is with the valve stem horizontal. Valves may be installed with the stem anywhere between horizontal or vertical for all sizes.
2. Ranger QCT valve with actuator is not recommended for installation with the actuator oriented downwards.
3. In no case is additional weight to be applied to the actuator subassembly when installed in any orientation.

#### ⚠ WARNING

The valve/actuator unit should not be used as a "step" to support personnel. Failure to comply may cause leakage at the flange/valve body joint, especially for flangeless body design.

#### B. Piping System:

1. It is recommended that the control valve unit be installed with a double-block and bypass as indicated in Figure 1. This arrangement is necessary when maintenance is to be done on the valve body. Valve must be removed from the pipeline to gain access to unit's internal trim parts.



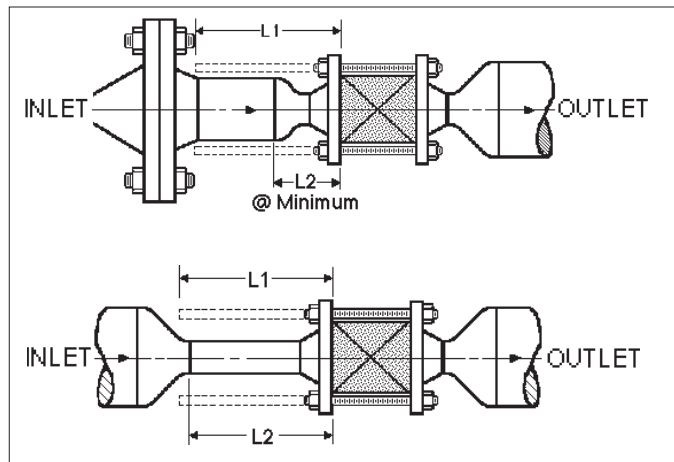
**FIGURE 1:** Typical Control Valve Station

2. If the pipe reducers, elbows, noise attenuation devices, etc., are located before and/or after the valve body, keep these pieces as close as practical to the valve body.

**NOTES:** 1. For flangeless design, allow sufficient clearance upstream from valve body for line bolt insertion and removal. See Figure 2 and Table 1.

2. Undue piping stress/strain or bending torques may not be transmitted through the control valve body. One pipe (inlet or outlet) should be anchored rigidly for piping that is "hot" or "cold" with respect to ambient temperature; the remaining pipe (inlet or outlet) should be supported and guided to ensure unidirectional expansion/contraction. Properly align prior to installing valve with required flange bolting.

3. Clean the piping of all foreign debris, including chips, weld scale, weld splatter, oil, grease, sand or dirt, prior to installing the control valve. **THIS IS AN ABSOLUTE REQUIREMENT!**
4. Field hydrostatic testing the completed piping system, including the Ranger QCT valve, to the max allowable CWP indicated on the valve's nameplate is acceptable. If hydro test pressure is to exceed this limit, the Ranger QCT must be removed before such testing. Before pressurization, the valve plug must be rotated out of the seat if of reverse, ATO-FC action.



**FIGURE 2:** Line Bolting Clearance

**TABLE 1 – LINE BOLTING REMOVAL CLEARANCE**

Body Size	Reducer Size	150# Flgs.		300# Flgs.		600# Flgs.	
		L1	L2	L1	L2	L1	L2
1" (DN25)	None	8.38 (213)	Min	8.75 (222)	Min	8.94 (227)	Min
	1-1/2"x1"		Min				
	2"x1"		Min				
	2-1/2"x1"		7.38 (187)				
1-1/2" (DN40)	None	8.44 (214)	Min	9.88 (251)	Min	10.12 (257)	Min
	2"x1-1/2"		Min		Min		
	2-1/2"x1-1/2"		Min		Min		
	3"x1-1/2"		Min		Min		
	4"-1-1/2"		7.44 (198)		8.88 (226)		9.12 (232)
2" (DN50)	None	10.06 (256)	Min	10.13 (257)	Min	10.50 (267)	Min
	2-1/2"x2"		Min				
	3"x2"		Min				
	4"x2"		9.00 (229)				
3" (DN80)	None	11.50 (292)	Min	13.44 (341)	Min	13.88 (353)	Min
	4"x3"		Min		Min		
	6"x3"		10.25 (260)		12.19 (310)		12.63 (321)
4" (DN100)	None	12.50 (318)	Min	13.56 (344)	Min	16.00 (406)	Min
	6"x4"		Min		Min		
	8"x4"		11.0 (279)		12.00 (305)		14.50 (368)
	10"x4"						
6" (DN150)	None	14.81 (376)	Min	16.25 (413)	Min	18.63 (473)	Min
	8"x6"		Min		Min		
	10"x6"		Min		Min		
	12"x6"		12.75 (324)		14.00 (356)		16.56 (421)
	14"x6"						
8" (DN200)	None	15.50 (394)	Min	18.75 (476)	Min	20.38 (518)	Min
	10"x8"		Min		Min		
	12"x8"		Min		Min		
	14"x8"		15.50 (394)		16.68 (424)		17.93 (455)
	16"x8"						

**C. Plug Position for Installation:**

**CAUTION**

DO NOT INSTALL ANY RANGER QCT VALVE WITH THE PLUG IN THE OPEN POSITION. The cage and seals may shift during installation. The resulting misalignment of plug and seals will negate the Class IV or Class VI seat leakage capabilities.

**NOTE:** All ATC-FO valves are shipped from the factory in the closed position to ensure alignment of body trim internals. After installing valve body in piping system, rotate valve plug to full open position.

1. All indicated Item Numbers that are with respect to IOM-48 or IOM148 will be in parenthesis and underscored; i.e. (20); the same is true for the positioner parts. All Item Numbers that are with respect to this IOM-Ranger are not underscored; i.e. (6).

2. For ATC-FO Direct Action Valves with Handwheel Assembly:
  - a. After installation in piping, loosen locking lever (59) and turn handwheel (58) CCW to fully open the plug (6).
  - b. Check travel indicator (16) to confirm valves full open plug position.
  - c. Tighten locking lever (59).

**NOTE:** For shipping and installation purposes these valves use a handwheel to temporarily hold the plug in the closed position.

**⚠ WARNING**

Do not adjust temporary air supply pressure after cover plate (20) has been removed. Valve contains parts which could move during maintenance exposing hand and/or fingers to a hazardous condition.

**D. Body Installation:**

The Ranger QCT body can be installed between ANSI Class 150, 300 or 600 lb. RF or FF flanges or their ISO equivalent of PN20, 50 or 100. Socket weld, weld neck or slip on companion flanges can be used. Face-to-face dimensions are per ISA 75.08.02.

1. Install valve so the flow direction matches the arrow on the valve body.
2. For flangeless design alignment, special bosses cast on the valve body contact the line bolting and help center the valve in the pipeline. See Table 2 for Line Bolting Dimensions.

**⚠ CAUTION**

DO NOT USE THE RANGER BODY ASSEMBLY AND LINE BOLTING TO PULL FLANGE PIPE ENDS INTO ALIGNMENT. Seal retainer may shift, damaging the seal retainer gasket allowing leakage between body and seal retainer. Movement of seal retainer may compromise the valve's ability to meet stated shut-off leakage rates. Could also allow leakage between body and flange pipe ends.

Valve Size	Line Flange ANSI Class	Tie Rod Studs		
		Dia.-Thd. UNC	Qty.	Length
1"	150	1/2"-13	4	7.75"
	300-600	5/8"-11	4	8.00"
1-1/2"	150	1/2"-13	4	7.75"
	300-600	3/4"-10	4	9.00"
2"	150	5/8"-11	4	9.25"
	300-600	5/8"-11	8	9.25"
3"	150	5/8"-11	4	10.50"
	300-600	3/4"-10	8	12.25"
4"	150	5/8"-11	8	11.50"
	300	3/4"-10	8	12.25"
	600	7/8"-9	8	14.25"
6"	150	3/4"-10	8	13.75"
		3/4"-10	10	14.75"
	300	3/4"-10	4	5.50"
		1"-8	10	16.50"
600	1"-8	4	6.75"	
	150	3/4"-10	8	15.50"
8"	300	7/8"-9	10	16.50"
		7/8"-9	4	6.25"

3. Line Bolting Material must comply with ANSIB16.34 and be compatible with the intended service.

**⚠ CAUTION**

Do not allow the body to "cock" between the flanges. Valve must be centered on the flanges.

4. Tighten the line bolting evenly and in small increments to avoid uneven loading of the seal retainer (3) and seal retainer gasket (9). See Table 3 for minimum and maximum line bolting torques.

Stud Size & Thread UNC	Max. Torque Ft-Lb.	Min. Torque Ft-Lb.
1/2"-13	65	60
5/8"-11	120	100
3/4"-10	200	140
7/8"-9	320	160
1"-8	440	180

**⚠ CAUTION**

Do not torque line bolting beyond the limitations of Table 3. Reference the "Ranger-TB" for temperature range of Opt-7A alloy steel and Opt-7C SST line bolting.

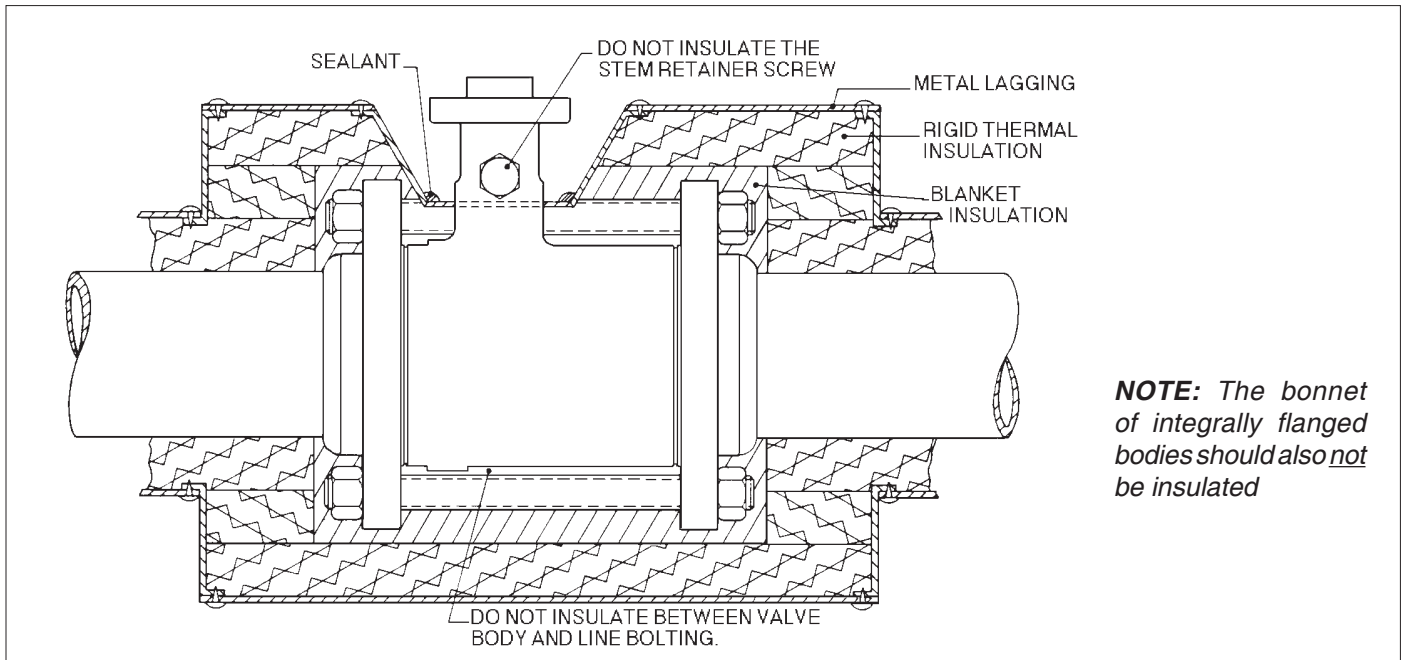
### E. Packing Check:

1. Ensure that packing flange nuts (22) have not worked loose during shipment.
2. For non-live loaded construction, hand tighten the nuts (22) enough to stop any leakage. Do not over tighten.
3. For live loaded construction, if spacer ring (29) is loose, tighten both nuts (22) equally

until spacer ring (29) no longer “spins freely” using two fingers. Rotate both nuts (22) additional 1/2 revolution for correct packing load. See Figure 9 for correct orientation of live-loaded packing design.

### F. Insulation:

1. Insulate the valve body only. Do not insulate the integral extension bonnet as this could result in premature packing failure in low or high temperature services. See Figure 3.



**FIGURE 3:**  
Insulated Body  
Flangeless Design

## SECTION IV

### IV. MAINTENANCE

#### A. General:

1. Maintenance procedures hereinafter are based upon removal of the valve/actuator unit from the piping where installed.
2. Owner should refer to owner’s procedures for removal, handling and cleaning of nonreusable parts; i.e. gaskets, suitable solvents, etc.
3. Valves supplied from the factory do not use any aid to assist in gasket sealing such as oil, sealant or pipe dope.
4. Valves originally supplied per Opt-55 require special cleaning procedures. Refer to Cashco Specification No. S-1134 for details. When in

compliance with/to Spec. No. S-1134, the valve is suitable for oxygen service. This procedure is limited to bodies of SST material

#### B. Trim Removal:

Access to the cage assembly with internal trim pieces may be accomplished without removing the actuator assembly (AA). Thus, it is not necessary to remove the packing set (13) or the stem subassembly (7) to change internal trims. **NOTE:** Plug (6) must be in the closed position to remove the trim.

1. Position valve on a flat work surface with the actuator assembly (AA) oriented vertical.

**NOTE:** If actuator assembly (AA) has been removed, rotate stem (7) to close plug (6), and proceed with Steps 4 through 8.

2. If the valve actuator includes a handwheel/adjusting screw (58) assembly, use handwheel/adjusting screw (58) to remove the closing torque; i.e. “stem windup”.

- a. **For ATO-FC valves:** Loosen locking lever/nut (59) with CCW rotation when viewed from above and rotate handwheel/adjusting screw (58) CW just enough to relieve the closing torque, but not enough to start opening the plug (approximately 1/2-1 handwheel revolution).
- b. **For ATC-FO valves:** Loosen locking lever (59) with CCW rotation when viewed from above and turn handwheel (58) CW to fully close the plug (6) and then back off enough to relieve the closing torque by reversing the handwheel/adjusting screw (58) CCW (approximately 1/2-1 handwheel revolution).
- c. Remove machine screws (36) and cover plate (20). Through opening in arm housing (4), insert a tool similar to a screwdriver and apply force to either side at the lower rod end (9). Rod end (9) will move easily from side to side when all closing torque has been relieved.

3. If the valve actuator does not include handwheel (58) assembly, connect a temporary air supply with an in-line adjustable airset regulator with gauge to the actuator top works. Remove machine screws (36) and cover plate (20).

## WARNING

Do not insert hands/fingers into body (1) or actuator arm housing (4) openings while actuator is pressurized.

- a. **For ATC-FO Valves:** Pressurize actuator to a level 2-3 psig (0.1-0.2 Barg) under the upper pressure level of the bench setting as stated on the name plate (21); i.e. 5-15 psig (.34–1.03 Barg) range, set pressure at 12-13 psig (.83-.90 Barg). Refer to 2.c. previous to confirm relief of all closing torque. Adjust actuator pressure slowly  $\pm 1$  to 2 psig ( $\pm .07$ –0.2 Barg) to confirm greatest/easiest movement of lower rod end (9).

4. Remove the seal retainer screws (18) and washers (23) and (47)
5. Remove the seal retainer (3) (full orifice, reduced, anti-cavitation, lo-noise), seal retainer gasket (9), soft seal (10) (if supplied) and metal seal (11).
6. Through backside of body (1), place a wooden hammer handle on the vane on the back side of the plug (6), or the LN2–LN4 lo-noise insert (25), and tap lightly to remove cage assembly.
7. Remove bearings (4)( 5) from the cage (2). (If necessary, pry or tap the bearings loose.) Rotate plug (6) 135° to 180° from the closed position and lift plug (6) from the cage (2).
8. Remove abrasion sleeve (26) or LN2–LN4 lo-noise insert, if installed.
9. Depressurize actuator for ATC-FO valves.

### C. Trim Reassembly:

Inspect and clean all parts. If any parts are worn, replace with new parts. If the stem assembly (7) has been removed, reassemble per Section IV, Subsection F., then proceed to reassemble the trim.

For sizes 1" - 3", Reorient unit so that the back-end of the body (1) is directed downwards, and the front-end is upwards and in a horizontal plane. In this position gravity will assist in proper alignment of internals. For 4" - 8" sizes orient body on its side.

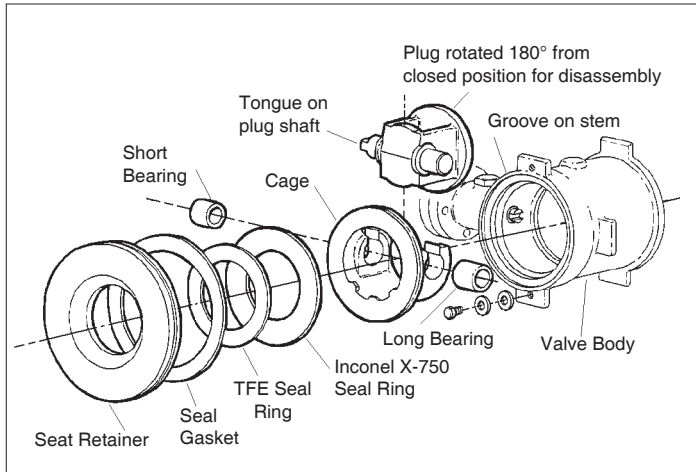
**NOTES:** A. The seal retainer gasket (9) and soft seal (10) should always be replaced after every disassembly. Use only original factory replacement parts.

B. **For ATC-FO Valves without handwheel (58) assembly:** Pressurize actuator to levels indicated per previous Subsection 3.a. to properly align groove in stem subassembly (7) to mate with the tongue on the plug (6).

1. Install LN2/4 “lo-noise” insert (25) or “abrasion sleeve” insert (26) into the body (1) cavity before inserting the cage/plug subassembly (2)(4)(5) (6). Ensure that the insert (25)(26) is properly located within the groove located in the back-end of the body (1)

**NOTE:** For proper orientation of LN2, LN3 or LN4 trims, see Figure 6.

- If at the body assembly (BA) level, ensure that the stem subassembly (7) is pulled back into the bonnet of the body (1) so that the stem (7) is in contact with the retainer sleeve subassembly (8).
- Place plug (6) into cage (2). The orientation must be such that the short stub shaft of the plug (6) with the machined tongue extends through the flat side of the cage (2) toward the stem (7). The plug (6) must be rotated 135° to 180° open before the plug (6) stub shafts will slip into the cage's (2) bearing (4) (5) slots. See figures 4 and 5.

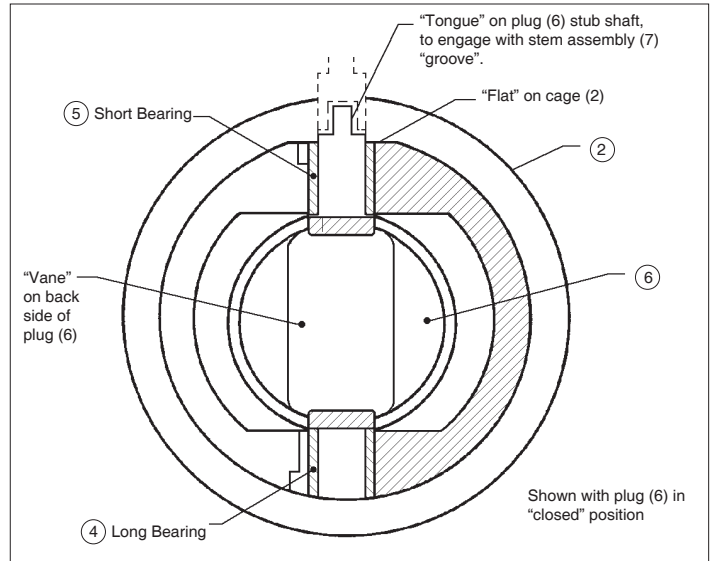


**FIGURE 4: Quick Change Trim Parts**

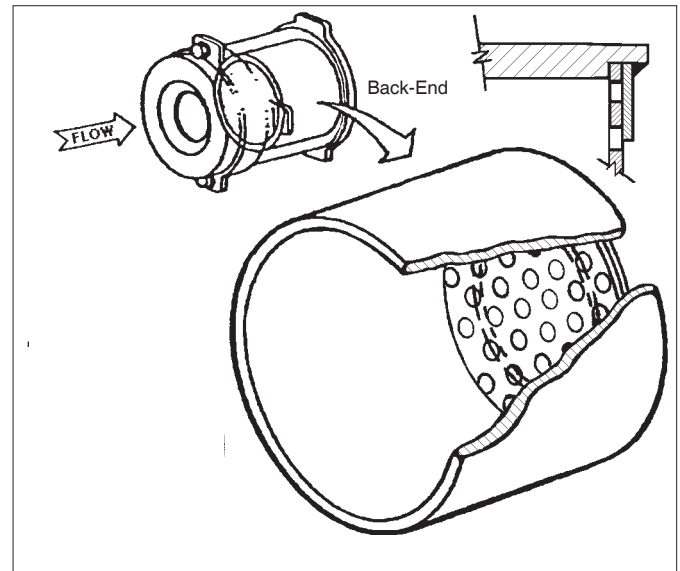
- Slip bearings (4)(5) onto the plug (6) stub shafts.

**NOTE:** Bearings (4) (5) are not the same length. The shorter bearing (5) fits the plug (6) stub shaft that has the tongue end. See Figure 5.

- Rotate plug (6) to the closed position. Ensure that the plug (6) is fully pulled into the mechanical stop (5) on the cage (2). See Figure 7. Ensure that the closing torque is nil; i.e. actuator assembly (AA) linkage is "loose" or "slack".
- Insert the cage/plug subassembly (2)(4)(5)(6) into the body (1). On 1-1/2" and 2" sizes with lo-noise inserts or abrasion sleeve, make sure these pieces and the cage (2) slip together on the back of the cage (2). Make sure the tongue on the plug (6) stub shaft and the groove in the stem subassembly (7) mate together. Check by looking in through the back-end of the body (1) or by adjusting the supply pressure to the actuator within limits of bench range as specified on name plate (21), watching for plug (6) movement as stem subassembly (7) rotates.



**FIGURE 5**  
Back-end view of Cage/Plug Subassembly

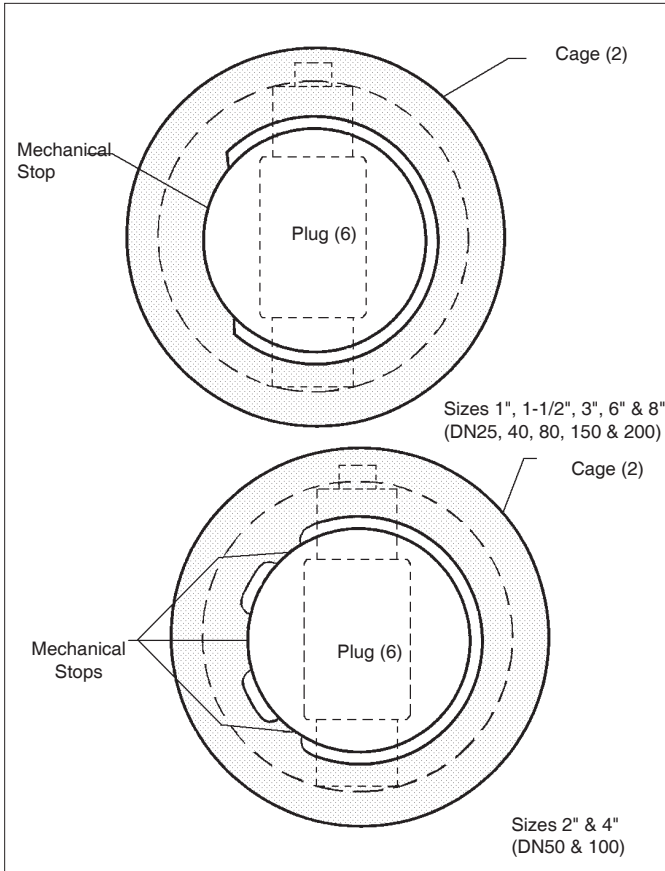


**FIGURE 6**  
Lo-Noise Trim – LN2 through LN4



**CAUTION**

1. If the tongue and groove are not mated together, trim parts could be damaged.



**FIGURE 7**

**Mechanical Travel Stops - Plug in Closed Position Front-End View**

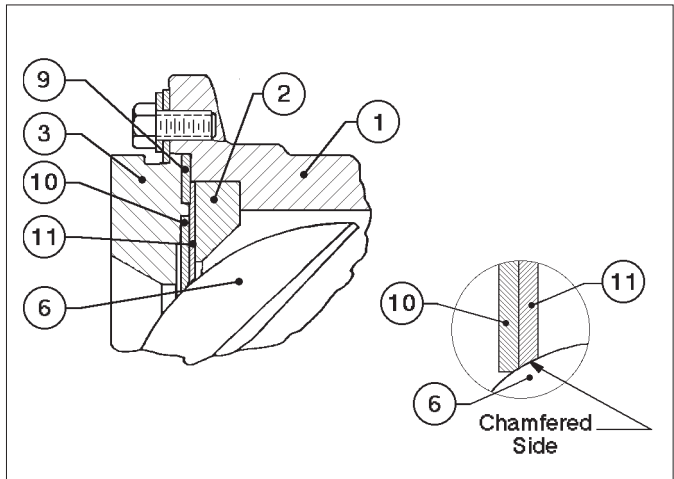
**NOTE:** All Sizes - Reorient unit so that the back-end of the body (1) is directed downwards, and the front-end is upwards and in a horizontal plane so seals properly align on plug.

- With plug (6) in the closed position, install the metal seal (11) with chamfered edge of I.D. toward the plug (6); a note is "etched" on the side of the metal seal (11) stating "TOWARD PLUG". Place seal retainer gasket (9) against body (1) face and metal seal (11). Place soft seal (10) against plug (6) face. See Figure 8 for assembly details.

**NOTE:** The soft seal (10) is not used with anti-cavitation trim (3) or with some trim designations. In reverse flow direction, the soft seal (10) is ineffective.

- Carefully set seal retainer (3) into position. Visually check to see if the soft seal (10) is centered over the metal seal (11), and that the plug (6) is closed.

**NOTE:** To center the seals on the plug (6) face, hold the seal retainer (3) against the assembled trim parts with light hand pressure and rotate the seal retainer (3) back and forth 90°, 3-4 times. Spin 360° 3-4 revolutions.



**FIGURE 8:**  
**Typical Seal Assembly**

- Install washers (23), Belleville washers (47) (convex side up) and cap screws (18) and hand tighten. Reduced port seal retainers (3) have recesses machined-in to receive the washers (23, 47). See Figure 17. These ensure that the elongated port (slot) is properly aligned. Wrench-tighten the cap screws (18) in 1/2 revolution increments, in an alternating pattern, until tight.

**NOTE:** The seal retainer gasket (9) and the soft seal (10) are not "set" until the valve is placed in the line and compressed between flanges. If the seals are "set" by clamping the valve between the flanges during a seat leakage test, retighten the cap screws (18) to hold the seal retainer (3) and seals (9, 10 and 11) firmly in place. Once a soft seal (10) is "set" by clamping the valve between flanges, it cannot be removed, reinstalled and then properly centered to provide Class VI shutoff.

- On ATO-FC and ATC-FO Valves without handwheel (58), replace cover plate (20) and machine screws (36). Depressurize the actuator for ATC-FO valves and disconnect temporary air supply.

- Return to Section III.A. through F. for installation instructions.

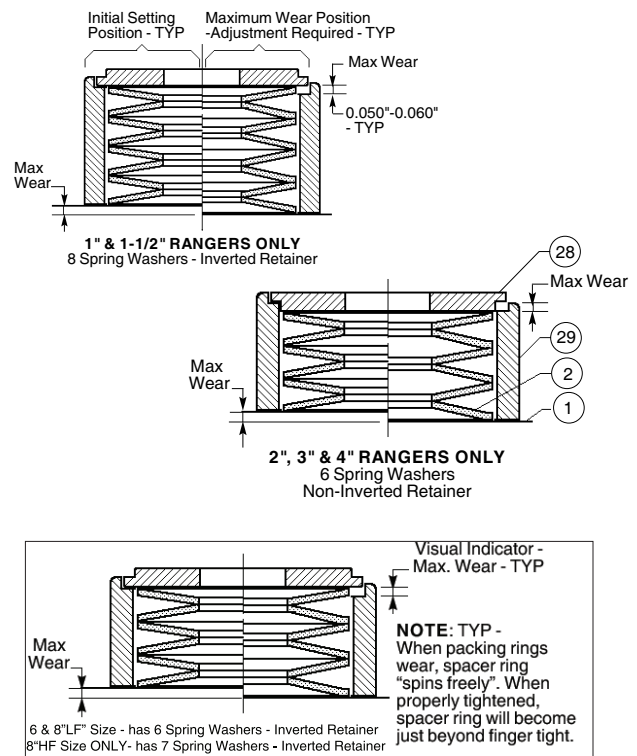
**D. Stem Removal:**

**⚠ CAUTION**

The valve must be isolated from the process, all pressures must be relieved and the unit removed from the piping system before attempting disassembly.

1. Remove the actuator assembly (AA) from the valve body assembly (BA). Refer to Actuator maintenance manuals IOM-48 or 148.
2. Secure body (1) in a vise with the stem (7) horizontal to the floor. Place matchmarks between yoke (12) and body (1) to assist in final orientation when re-assembled.
3. For live-loaded construction:

- a. Loosen both packing flange nuts (22) until clearance exists between the bottom of the nut (22) and the retainer (28).
- b. Spacer ring (29) should “spin freely”. If stacked mechanism (27)(28)(29) is not loose due to corrosion, debris, packed dirt, etc., tap the spacer ring (29) lightly while attempting to pry up the spacer ring (29) bottom with a thin flat tool.
- c. Remove both packing flange nuts (22) only after the live-loaded mechanism (27)(28)(29) is “free” and loose.
- d. Pry up both live-loaded mechanisms (27)(28)(29) one side at a time. Carefully lift the mechanism (27)(28)(29) over the packing stud (21) ensuring that the Belleville spring washers (27) are not dropped in removal, preventing a determination of washers' (27) orientation one-to-the-other. Set the two mechanisms (27)(28)(29) down together, side by side.
- e. Inspect the retainers (28) for orientation. Both of the retainers (28) should have the same orientation. Improper/differing orientations will cause unbalanced loading of the packing rings (13). See Figure 9 for proper orientation.
- f. Inspect both spring washer (27) stacks for proper orientation by carefully lifting off the spacer ring (29) and retainer (28), exposing the spring washer (27) stack. Each stack of spring washers (27) should be oriented the same. Improper/differing orientation will cause unbalanced loading of the packing rings (13). See Figure 9 for proper orientation.
- g. Replace all Belleville spring washers (27) if there are any signs of corrosion. It is recommended that spring washers be replaced in full sets. The spacer rings (29), retainers (28), as well as the packing studs (21) should be replaced if corroded.
- h. Remove yoke (12) bolting by removing two cap screws (19) on 1", 1-1/2" and 2" sizes, or two nuts (22) on the 3", 4", 6" and 8" sizes.

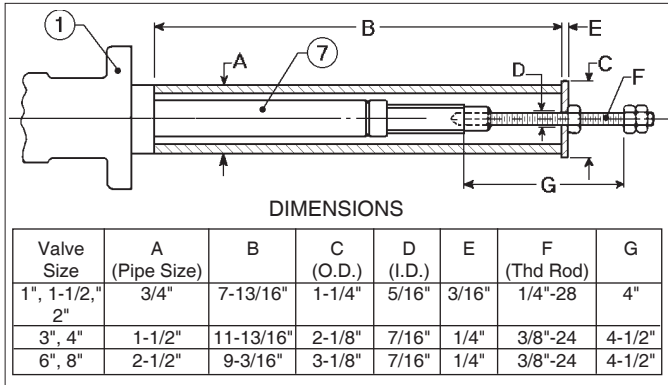


**FIGURE 9**

**Ranger Live-Loaded Packing Design**

- i. Pull yoke (12), packing flange (14), packing follower (15) and follower bushing strip (16) off over end of stem (7). Replace packing follower (15) if significantly corroded. Always replace follower bushing strip (16) when of standard construction. **(NOTE: When Opt-38HT high temperature packing is supplied, the packing follower (15.1) contains a pressed-in carbon bushing (15.2) that is not field replaceable and must be supplied as a packing follower (15) subassembly.)**
- j. Loosen stem retainer screw (17) by rotating CCW (viewed from above screw head) 2-3 revolutions to check for trapped fluid. After all fluid is vented, remove screw (17).
- k. Rotate stem (7) CW when viewed from actuator end of stem (7) to close plug (6).
- l. Withdraw stem subassembly (7), retainer sleeve subassembly (8) and packing set (13) out of body (1).

**NOTE:** If difficulty is encountered in removing the stem subassembly (7), use a puller assembly. See Figure 10. Hold the double nut with a wrench to prevent rotation of the stem as this could damage the seals if the trim is still in the valve body (1). Use the single nut to jack the stem subassembly (7) out.



**FIGURE 10: Stem Puller**

- m. Using a suitable solvent acceptable to the owner, thoroughly clean the valve stem (7) and the body's (1) stuffing box. Inspect surface finish of stem subassembly (7) and internal wall finish of packing box bore at packing (13) area. If deeply scratched, corroded or pitted, replace with new parts.
- n. It will be desirable to restore the surface of the body's (1) stuffing box to 16 micro-inch Ra finish; metal removal should not exceed 0.001 inch material.
- o. It will be desirable to restore the surface of the stem's (7) critical area to 6–8 micro-inch Ra finish or better, metal removal should not exceed 0.001 inch material. Minimum stem OD should not be less than indicated in Table 4.
- p. Remove retainer sleeve subassembly (8) from stem subassembly (7). Examine carbon bushing insert of retainer sleeve subassembly (8) for damage or signs of wear. Replace retainer sleeve subassembly (8) if worn more than 0.005 inch (0.13 mm). See Figure 12 for indicated dimension "X".

**⚠ CAUTION**

The tongue and groove connection between the stem subassembly (7) and the plug (6) can cause mechanical damage or disengagement if the carbon bushing insert is worn.

- q. Examine packing studs (21) and nuts (22). Replace if signs of corrosion are present.

Body Size	Minimum Stem O.D.
1", 1-1/2" & 2" (DN25, 40 & 50)	.620
3" & 4" (DN80, 100)	.995
6" & 8" (DN150, 200)	.995

4. For Non-Live-Loaded Packing Construction:

- a. Remove two packing flange stud nuts (22) and two cap screws (19) on the 1", 1-1/2" and 2" sizes, or four nuts (22) on the 3", 4", 6" and 8" sizes.
- b. Pull yoke (12), packing flange (14), packing follower (15) and follower bushing strip (16) off over end of stem (7). Replace packing follower (15) if significantly corroded. Always replace follower bushing strip (16) when of standard construction.
- c. Proceed with previous steps 3.j. through 3.q. for stem removal.

**E. Stem Reassembly – Trim Retained in Body:**

1. Slide retainer sleeve subassembly (8) onto the stem subassembly (7), with the carbon bushing (8.2) end against the shoulder of the stem subassembly (7).

**NOTE:** For Slurry Trim see Subsection H.

2. Insert the stem/retainer sleeve (7)(8) assembly into the body (1), aligning the hole in the retainer sleeve (8) to be directly in line with the threaded hole in the body (1) bonnet. Align the stem subassembly (7) so that the plug's (6) tongue and the stem's (7) groove will engage.

**NOTE:** A small "flat" area has been milled on the stem and for correct engagement this "flat" must be on the same side as the face of the plug (6).

**⚠ CAUTION**

Do not hammer on end of stem. Potential exists to cause damage to the tongue and groove connection or to the seals.

3. Visually confirm alignment of hole in retainer sleeve (8.1) with threaded hole in body (1) bonnet. Place thread sealant Cotronic Resbond 907, or equal, on stem retainer screw (17) threads for valves **used in non-oxygen service**; thread sealant to be Occidental Petroleum Corp. Fluorolube GR-362, or equal, for valves **used in oxygen service**. Insert and tighten stem retainer screw (17) 20-25 ft# (27-34 N-M) for 1"– 2" sizes, 80-85 ft# (108-115 N-M) for 3"– 8LF" sizes and 90 ft# (122 N-M) for 8"HF size.
4. Rotate stem (7) to ensure tongue and groove engagement with plug (6).

- Proceed to Subsection G. for installation of packing (13).

#### F. Stem Reassembly – Trim Removed from Body

- Install retainer sleeve subassembly (8) and stem subassembly (7) in accordance with Subsection E, Articles 1 through 3, previous. Rotate stem (7) to plug's (6) closed position.
- Install trim in accordance with Subsection C, Articles 1 through 10, previous.
- Install packing in accordance with Subsection G.

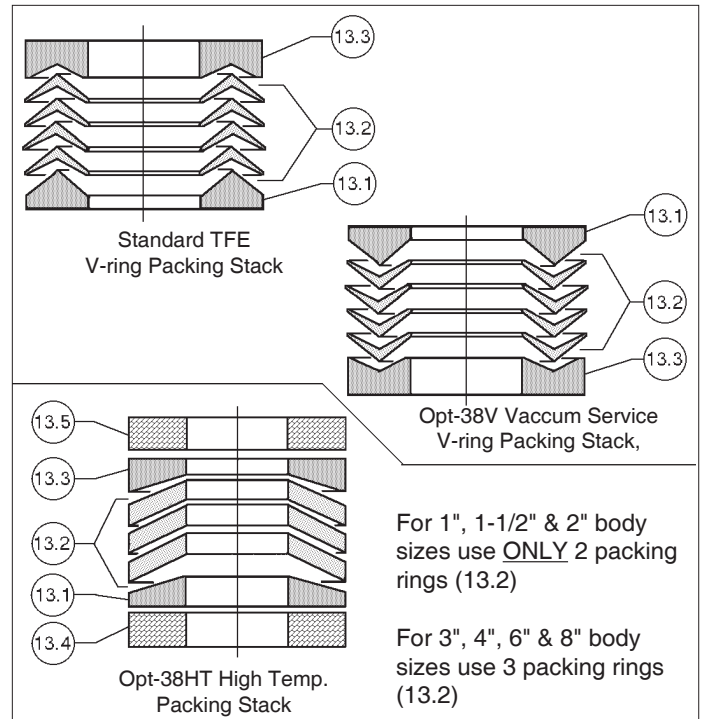
#### G. Packing Replacement:

Remove stem as per Subsection D. previous and proceed as follows.

- Secure body (1) in a vise with stem (7) vertical to the floor. Reassemble stem (7) per appropriate Subsection E., F., or H.
- Never replace packing (13) without reconditioning the stem (7) surface finish and the body (1) stuffing box as specified in Subsection IV.D.
- For TFE V-Ring Packing. (See Figure 11.)

**NOTE:** Following text pertains to “standard” packing stack (13) orientation. Stack procedures differ slightly for other packing options. See Figure 11.

- Remove packing follower bushing strip (16). Solvent clean packing follower (15). Insert new packing follower bushing strip (16). Ensure no overlap of strip (16).
- Carefully place lower adapter (13.1) of packing ring set (13) over stem's (7) end, properly oriented (see Figure 11). Using the packing follower (15), push the adapter (13.1) into the body's (1) stuffing box.
- Carefully install the first individual V-ring (13.2) over stem's (7) end, properly oriented. Push down as far as possible using fingers. Carefully place each ring (13.2) upon the other until all V-rings (13.2) are stacked, properly oriented.
- Place upper adapter ring (13.3) over the stem's (7) end, properly oriented.
- Place the packing follower (15) over the stem (7) end, properly oriented, until sitting on the upper adapter ring (13.3). Push down on the packing follower (15) using fingers; all V-rings (13.2) and upper



**FIGURE 11**  
Packing Stack Orientation

adapter (13.3) should easily slide into the body (1) stuffing box.

**NOTE:** It will be necessary to pull up on the stem (7) as the adapters (13.1, 13.3) and packing rings (13.2) are “pushed” into the stuffing box.

- For body sizes 1", 1-1/2" & 2":
  - Slide both yoke (12) and packing flange (14) over end of stem (7), properly oriented, and over packing studs (21). Align matchmarks between body (1) and yoke (12).
  - Install two cap screws (19) to assemble the yoke (12) to the body (1) securely.
- For body sizes 3", 4", 6" & 8":
  - Slide yoke (12) over end of stem (7), properly oriented, and over packing studs (21). Align matchmarks between body (1) and yoke (12).
  - Slide packing flange (14) over end of stem (7), properly oriented, and over packing studs (21).
  - Install two nuts (22) on studs (20) to assemble the yoke (12) to the body (1) securely.
- Proceed to Article 6 for Opt-38 Jammed Packing.

With Externally Live-Loaded Construction proceed as follows:

- i. Place each spring washer (27) stack over its packing stud (21) oriented as shown in Figure 9.
  - j. Place each spacer ring (29) over its packing stud (21) and spring washer stack (27) oriented as shown in Figure 9.
  - k. Place each retainer (28) over its packing stud (21) oriented as shown in Figure 9. Ensure that each retainer (28) is properly positioned into each spacer ring's (29) groove, and that the retainer's (28) inversion is correct.
  - l. Proceed to Article 5. , this Subsection.
4. For Opt-38HT High Temp Packing:
- a. Solvent clean the packing follower (15).
  - b. Carefully place the lower braided ring (13.4) over the stem's (7) end. Using the packing follower (15) push the braided ring (13.4) into the body's (1) stuffing box. **NOTE:** *It will be necessary to pull up on the stem (7) as the rings (13.2, 13.4) and lower adapter (13.1) are "pushed" into the stuffing box.*
  - c. Carefully place the lower adapter (13.1) properly oriented (see Figure 11) over the stem's (7) end and push into the stuffing box similar to the lower braided ring (13.4) of Step 4.b.
  - d. Carefully place a packing ring (13.2) properly oriented (see Figure 11) over the stem's (7) end and push into the stuffing box similar to the lower braided ring (13.4) of Step 4.b. Repeat for each ring (13.2).
  - e. Carefully place the upper adapter (13.3) similar to the lower retainer (13.1) of Step 4.b. Leave packing follower (15) in position, properly oriented.
  - f. Place the packing flange (14) over the stem's (7) end and over the packing studs (21). Place the retainer (28) over each stud (21). Install packing nuts (22) and finger-tighten.
  - g. Wrench-tighten the packing nuts (22) in 1/2 revolution increments until the "upper groove" identified as "Line A" (see Figure 13) on the packing follower (15) is flush with the top edge of the body's (1) stuffing box.
  - h. Remove the packing nuts (22), retainers (28), packing follower (15) and packing flange (14).
  - i. Carefully place the upper braided ring (13.5) over the stem's (7) end and push into the stuffing box similar to the lower braided ring (13.4) of Step 4.b. Leave packing follower (15) in position.
  - j. Place the packing flange (14) over the stem's (7) end and over the packing studs (21). Place the retainers (28) over each stud (21). Install packing nuts (22) and finger-tighten.
  - k. Repeat Step 4.g. with the exception that the packing set (13) is to be compressed into the stuffing box until the "lower groove" identified as "Line B" (see Figure 13) on the packing follower (15) is flush with the top edge of the body's (1) stuffing box.
  - l. Remove the packing nuts (22), retainers (28) and packing flange (14).
  - m. For body sizes 1", 1-1/2" & 2":
    - m.1. Slide both yoke (12) and packing flange (14) over end of stem (7), properly oriented, and over packing studs (21). Align matchmarks between body (1) and yoke (12).
    - m.2. Install two cap screws (19) to assemble the yoke (12) to the body (1) securely.
  - n. For body sizes 3", 4", 6" & 8":
    - n.1. Slide yoke (12) over end of stem (7), properly oriented, and over packing studs (21). Align matchmarks between body (1) and yoke (12).
    - n.2. Slide packing flange (14) over end of stem (7), properly oriented, and over packing studs (21).
    - n.3. Install two nuts (22) on studs (20) to assemble the yoke (12) to the body (1) securely.
  - o. Place each spring washer (27) stack over its packing stud (21) oriented as shown in Figure 9.
  - p. Place each spacer ring (29) over its packing stud (21) and spring washer (27) stack oriented as shown in Figure 9.
  - q. Place each retainer (28) over its packing stud (21) oriented as shown in Figure 9. Ensure that each retainer (28) is properly positioned into each spacer ring's (29) groove, and that the retainer's (28) inversion is correct.
5. Common For All Live-Loaded Designs:
- a. Install packing nuts (22) finger-tight down to each retainer (28).
  - b. Draw down each packing nut (22) in alternating 1/2 revolution increments,

checking each spacer ring (29) after each tightening. When spacer ring (29) can no longer be rotated freely by fingers, make an additional 1/2 revolution – no further tightening should occur to maintain the “live-loaded” intent of the design. Overtightening of the design as described causes the mechanism to function as a “jammed packing. This will defeat the design intent of the mechanism and will increase packing (13) wear.

- c. Refer to Actuator Maintenance Manuals IOM-48 or 148 to reconnect actuator/arm housing (AA) to yoke (12).

6. Common to Opt-38J Jammed Packing Only:

**NOTE:** Packing follower (15) must penetrate into the stuffing box of the body (1).

- a. Install nuts (22) on packing studs (21) and finger tighten.
- b. Refer to Actuator Maintenance Manuals IOM-48 or 148 to reconnect actuator/arm housing (AA) to yoke (12).
- c. Tighten packing nuts (22) to torque levels indicated in Table 5.

Table 5		
Packing Nut Torques		
Body Size	Torque	
	in-lbs.	N-M
1", 1-1/2", 2" (DN25, 40, 50)	50	67
3", 4" (DN80, 100)	130	176
6" & 8" (DN150, 200)	165	223

**NOTE:** When valve is returned to operation, check for leakage and tighten the nuts (22) evenly in alternating 1/4 revolution increments until leakage stops. **DO NOT OVERTIGHTEN.**

**H. Slurry Trim – Opt-AS:**

- 1. Install the trim in the body (1) per Section IV,

Subsection C, Articles 1 through 10.

- 2. Slide retainer sleeve subassembly (8) onto the stem assembly (7) with the stem retainer carbon bushing (8.2) end against the stem (7) subassembly shoulder.
- 3. Apply lubricant (silicon grease or equivalent) to O-ring (30), and slide backup ring (31) and O-ring (30), respectively, into groove on stem (7) groove-end. See Figure 21 for O-ring (30) orientation.
- 4. Insert the stem/retainer sleeve (7)(8) assembly into the body (1), aligning the hole in the retainer sleeve (8) to be directly in line with the threaded hole in the body (1) bonnet. Align the stem subassembly (7) so that the plug's (6) tongue and the stem's (7) groove will engage. Insert assembly.

**CAUTION**

If O-ring (30) on stem subassembly (7) is inserted into the body (1) cavity and then pulled back into the bonnet, the O-ring (30) may be damaged.

**NOTE:** A small "flat" area has been milled on the stem and for correct engagement this "flat" must be on the same side as the face of the plug (6).

- 5. Visually confirm alignment of hole in retainer sleeve (8.1) with threaded hole in body (1) bonnet. Insert and tighten stem retainer screw (17).
- 6. Rotate stem (7) to ensure tongue and groove engagement with plug (6).
- 7. Proceed to Section IV, Subsection G. for installation of packing (13).

**J. Pressure Test:**

- 1. Cashco recommends that a pressure integrity test be performed following reassembly when the packing set (13) has been replaced.

## SECTION V

### V. STARTUP

#### A. General:

1. Ensure that the Ranger QCT unit has been properly adjusted and calibrated, including the positioner if installed, per actuator maintenance manuals IOM-48 or 148.
2. Recommend startup to be in “manual” mode. This procedure assumes double block (isolation) and bypass valves for the “control valve station”. See Figure 1.
3. Start with one of the two block valves closed, with the other open. The bypass valve should be closed. Pressurize system if possible/practical.
4. Back out the airset's adjusting screw until loose.
5. Turn on air supply pressure.
6. Adjust the air supply airset (filter-regulator) to the proper level as indicated on the unit's nameplate (20), in IOM-48 or IOM-148, or the technical bulletin Ranger-TB. **DO NOT STROKE THE CONTROL VALVE WITH AN AIR SUPPLY PRESSURE SETTING GREATER THAN RECOMMENDED MAXIMUM PRESSURE!**
7. Place loop controller into “manual” mode. Vary setting from minimum – mid-range — maximum SIG output. Observe response of control valve unit to these changes of input SIG. The valve should fully stroke at the variation from minimum SIG to maximum SIG; the mid-range SIG should have the valve stem travel at/near 1/2 open.
8. Confirm that action of controller and positioner – direct or reverse – are producing the desired response in the control unit. Confirm that the control valve “fail” position is as required.

9. Hereafter, the procedure assumes that actual fluid flow may be established. This may not be practical/possible in all cases; if so, vary procedure as required.

Always “heat” or “cool” down the system piping SLOWLY by opening the control valve station bypass valve in small increments.

#### **WARNING**

**DO NOT WALK AWAY AND LEAVE A MANUALLY CONTROLLED CONTROL VALVE UNATTENDED!**

10. With one of the control valve station block valves still closed, and the loop controller still in “manual” mode, open bypass valve and vary flow rate manually to observe the response of the controller and control valve unit together.
11. Attempt to develop manual control of the loop by opening/closing the manual bypass as required, or by manually controlling mainstream flow as required.
12. When the control valve is partially open, slowly crack open the closed block valve while simultaneously closing the bypass valve; it may be necessary/desirable to vary the manual output SIG from the controller simultaneously also. Continue this procedure until the bypass is closed and the block valves are both fully open. The system is still under “manual” mode control, but all flow is passing through the control valve.
13. Vary controller “manual” SIG output until matching the “automatic” SIG output, then change the mode of the controller over to “automatic”, and the loop will experience a minimum of upset conditions, and will be in automatic control.

## SECTION VI

### VI. TROUBLE SHOOTING GUIDE

The information that follows is specific to address problems related to the valve body assembly. Refer to the Rotary Actuator Maintenance Manual IOM-48 or 148 for issues related to valve travel, bench range, calibration, etc.

#### 1. Valve is “jumpy” in stroking.

Possible Cause	Remedy
A. Excess packing friction.	A1. Once packing is overtightened, the valve must be removed from operation and pressurization, packing removed, and new packing installed. A2. Install positioner.
B. Stem seized due to corrosion/buildup of scale.	B1. Disassemble valve and remove buildup. Give consideration to installing slurry trim option. B2. Consider stem purge.
C. Feedback linkage is bent; cam follower worn.	C1. Replace feedback linkage and character cam. C2. Ensure alignment between cam in arm housing and feedback linkage is centered. C3. Ensure that the carbon bushing of the stem retainer subassembly has not worn and allowed the stem to move outward along its axis. If bushing wear seems premature, consider replacing with stellite bushing over carbon. C4. Arms are not tightly clamping to the stem. Tighten bolt/nut securing arms.
D. Actuator spring problems.	D1. Broken spring. Replace <u>all</u> springs. D2. Non-symmetrical positioning of springs; ensure that springs are symmetrical; i.e. springs 180° across from each other.

#### 2. Valve exhibits “excess” vibration.

Possible Cause	Remedy
A. Excess pressure drop.	A1. Bring pressure drop within design limits. A2. Stage pressure drop using multiple valves in series.
B. Excessive cavitation in liquid service.	B1. Change flow conditions, if possible. B2. Increase back pressure on valve's outlet using a <u>downstream</u> restriction. B3. Place a restriction <u>upstream</u> of the control valve. B4. Do both B2 and B3. B5. Consider use of anti-cavitation seal retainer; reverse flow direction required. B6. If standard flow direction, reverse flow direction. B7. Cool the liquid. B8. Use multiple valves in series.
C. High Outlet Noise Level	C1. Reduce pressure drop, if possible. C2. Reduce flow rate, if possible. C3. Install lo-noise trim, 1-stage or 2-stage. C4. Split flow into two parallel streams with two control valves. C5. Stage pressure drop using two control valves in series. C6. Place a restriction downstream of the control valve. C7. Place a restriction upstream of the control valve. C8. Do both C6 and C7. C9. Noise trim worn/damaged; replace lo-noise trim. C10. Trim wear; replace trim. C11. Install fluorocarbon elastomer spacer if there is a “slot” for soft seal in retainer, but no seal is installed.

3. Valve exhibits “excess” seat leakage.

**NOTE:** The Ranger QCT incorporates both a metal seal and a soft seal in many trim designs. For some options and trim designs the soft seal is omitted. Soft seals are never used in “reverse” flow direction.

Possible Cause	Remedy
A. Valve stroke limited mechanically.	<p>A1. Loosen locking lever (59) and rotate handwheel (58) CCW to its positive up-stop position. Retighten locking lever.</p> <p>A2. Properly adjust actuator up-stop washer.</p> <p><b>NOTE:</b> DO NOT ADJUST THE ACTUATOR JAM NUT (45) AND STOP SCREW (35).</p>
B. Improper actuator bench setting.	<p>B1. Calibrate actuator to valve.</p> <p>B2. Ensure proper engagement of push rod linkage from actuator to valve stem.</p>
C. Excess trim wear.	<p>C1. Erosive service, remove particulate from services.</p> <p>C2. Use “ST6” trim designation numbers; flow to be in “reverse” direction.</p> <p>C3. Possible excess cavitation in liquid service. Change operation parameters. Use anti-cavitation trim.</p> <p>C4. Incorporate trim using fluorocarbon elastomer spacer.</p> <p>C5. Install abrasion sleeve.</p>
D. Soft seal leakage	<p>D1. Erosive service; remove particulate from services.</p> <p>D2. If steam pressure exceeds 150 psig, switch to ST7 trim designation number.</p> <p>D3. If <math>T_1</math> is greater than 400°F, switch to trim designation number S7.</p> <p>D4. Valve travel restricted; plug not “pulling into” cage stops.</p> <p>D5. Wrong flow direction. Soft seal ONLY effective in standard/forward flow direction.</p> <p>D6. Insufficient <math>\Delta P</math>. Soft seal is pressure energized.</p>
E. Metal seal leakage	<p>E1. Damaged seal due to debris in flow stream. Replace seal.</p> <p>E2. Over-temperature of soft seal; soft seal deforms over edge of metal seal ring. Remove soft seal or switch to trim designation number ST7.</p> <p>E3. Install fluorocarbon elastomer spacer if no soft seal is installed.</p> <p>E4. Valve travel restricted; plug not “pulling into” cage stops.</p> <p>E5. Erosive wear. Replace seal.</p> <p>E6. High velocity. Check sizing for velocity &amp; noise.</p>

4. Premature Packing Leakage.

Possible Cause	Remedy
A. Over-temperature.	A1. Remove insulation along body to allow direct contact with ambient air. A2. Replace standard packing with high-temp. packing - requires positioner.
B. Improper packing orientation.	B1. Ensure correct stack up of packing pieces. B2. Determine if packing is being exposed to a vacuum at any time. Consult factory if vacuum is occurring.
C. Insufficient force/packing follower loose.	C1. Tighten packing follower/nuts to indicated dimension per Section 8. Replace with new packing assembly as necessary. C2. Replace packing spring washers if corrosion is obvious.
D. New valve installed at operating pressures and temperatures.	D. Adjust per Section III, Subsection E.

5. Seal Retainer/Flange Leakage

Possible Cause	Remedy
A. Improper pipe supports and anchors.	A. Provide piping anchors and guides at control valve station. Restrain bending movements.
B. Incorrect line bolting.	B. Use high strength line bolting heat treated alloy steel (Opt-7A) or corrosion resistant SST strainer hardened studs (Opt-7C).
C. Flange bolting unevenly loaded.	C1. Loosen and remove line bolting, replace flange gasket and reinstall flange bolting. See Table 3, Section III, for line bolting torques. C2. Valve used to "pull" pipe into alignment. Loosen bolting, properly align pipe and retighten bolting.
D. Incorrect seal retainer gasket material.	D. Remove seal retainer gaskets and replace with factory supplied flexitallic gaskets.
E. Corrosion	E. Consult factory.

6. Insufficient Capacity.

Possible Cause	Remedy
A. Wrong valve size.	A. Recheck original sizing conditions with actual calculated Cv and install new trim pieces or complete valve as necessary.
B. Seal retainer too small.	B. Change seal retainer size in accordance to Cv calculations.
C. Improper actuator bench setting.	C. Calibrate actuator to valve for 90° travel.

7. Valve does not respond to changes in signal.

Possible Cause	Remedy
A. Improper control action(s).	A1. Disconnect signal to actuator to determine control valve action. A2. Determine controller output action. A3. Determine positioner output action.
B. Plug tongue and stem grove not engaged. Carbon bushing insert in retainer sleeve assembly is worn.	B1. Replace carbon bushing insert. Refer to Figure 2 for critical dimension. B2. Consider change to stellite bushing.
C. Damaged positioner linkage.	C. Inspect linkage. Replace if necessary.
D. Damaged actuator stem linkage.	D. Replace linkage. Ensure not overpressuring.
E. Plug bearings not properly fitted during reassembly	E. Reinstall bearings – shorter bearing fits plug shaft that has tongue milled on it.
F. Plug tongue and stem groove connection	F. Replace both stem and plug. Determine cause of this failure prior to reassembly.

## SECTION VIII

### VIII. ORDERING INFORMATION NEW REPLACEMENT UNIT vs PARTS "KIT" FOR FIELD REPAIR

To obtain a quotation or place an order, please retrieve the Serial Number and Product Code that was stamped on the metal name plate and attached to the unit. This information can also be found on the Bill of Material ("BOM"), a parts list that was provided when unit was originally shipped. (Serial Number typically 6 digits). Product Code typical format as follows: (last digit is alpha character that reflects revision level for the product).

□□□□ - □□□□ 7 - □□□□□□□□□□

#### NEW REPLACEMENT UNIT:

Contact your local Cashco, Inc., Sales Representative with the Serial Number and Product code. With this information they can provide a quotation for a new unit including a complete description, price and availability.

#### PARTS "KIT" for FIELD REPAIR:

Contact your local Cashco, Inc., Sales Representative with the Serial Number and Product code. Identify the parts and the quantity required to repair the unit from the "BOM" sheet that was provided when unit was originally shipped.



#### **CAUTION**

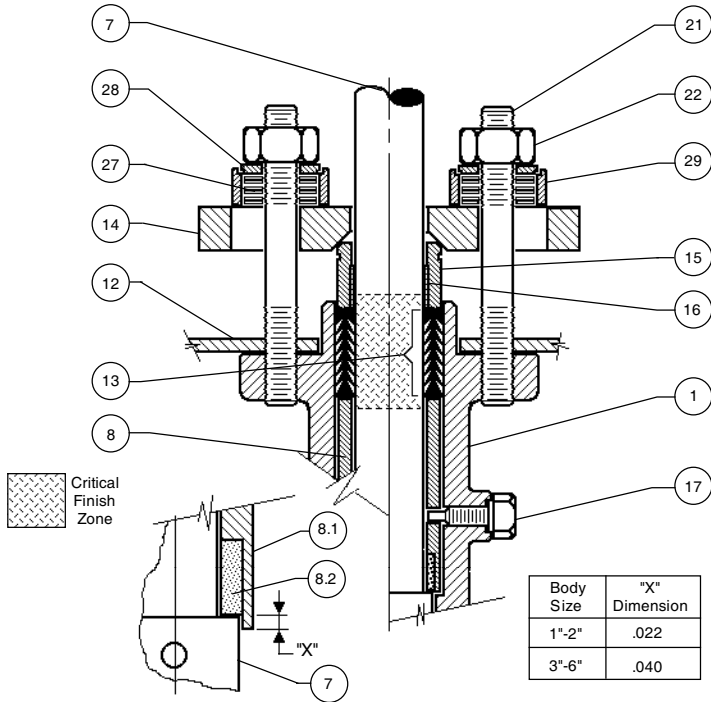
**Do not attempt to alter the original construction of any unit without assistance and approval from the factory. All purposed changes will require a new name plate with appropriate ratings and new product code to accommodate the recommended part(s) changes.**

**NOTE:** *Those part numbers that have a quantity indicated under "Spare Parts" in column "A" reflect minimum parts required for inspection and rebuild, - "Soft Goods Kit". Those in column "B" include minimum trim replacement parts needed plus those "Soft Goods" parts from column "A".*

If the "BOM" is not available, refer to the cross-sectional drawings included in this manual for part identification and selection.

A Local Sales Representative will provide quotation for appropriate Kit Number, Price and Availability.

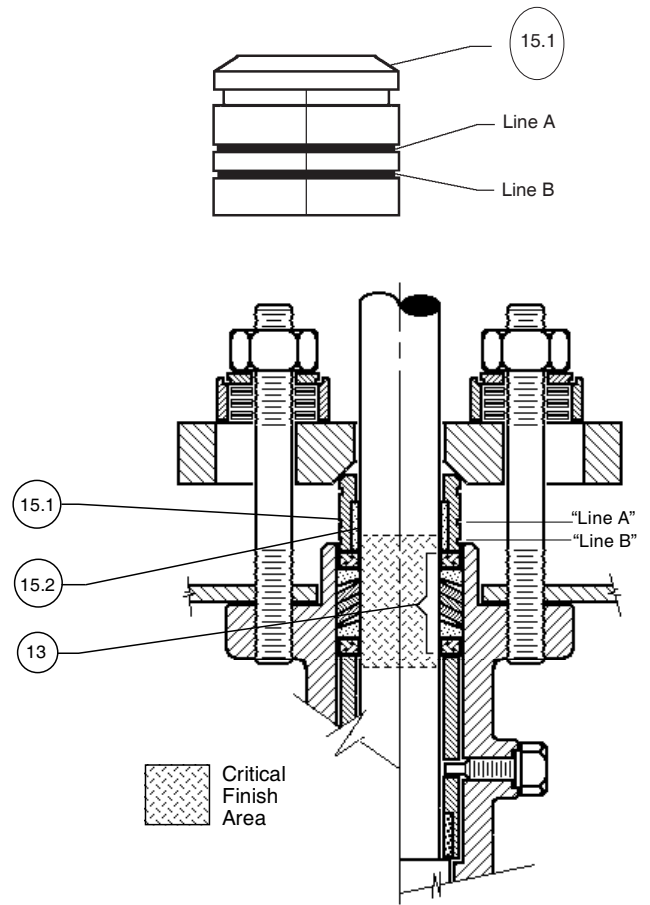
The contents of this publication are presented for informational purposes only, and while every effort has been made to ensure their accuracy, they are not to be construed as warranties or guarantees, express or implied, regarding the products or services described herein or their use or applicability. We reserve the right to modify or improve the designs or specifications of such product at any time without notice. Cashco, Inc. does not assume responsibility for the selection, use or maintenance of any product. Responsibility for proper selection, use and maintenance of any Cashco, Inc. product remains solely with the purchaser.



Body Size	"X" Dimension
1"-2"	.022
3"-6"	.040

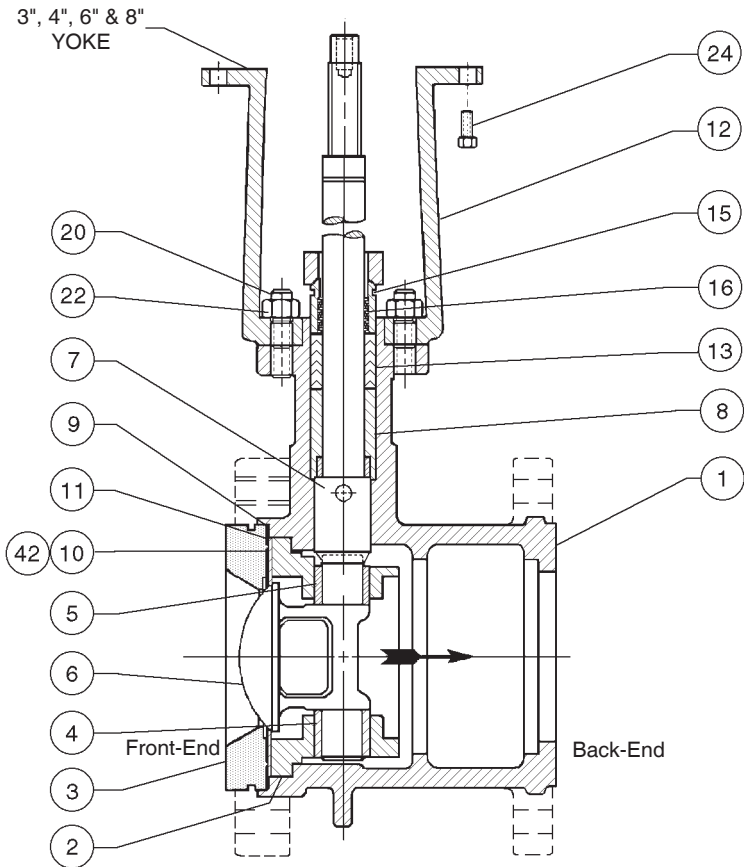
Item No.	Part Description	Item No.	Part Description
1	Body	15	Packing Follower
7	Stem Subassy.	16	Follower Bushing Strip ‡
8	Stem Retainer Subassy.	17	Stem Retainer Screw
8.1	Retainer Sleeve	21	Packing Stud
8.2	Carbon Bushing ‡	22	Packing Stud Nut
12	Yoke	27	Belleville Spring Washers
13	Packing Ring Set ‡	28	Retainer
14	Packing Flange	29	Spacer Ring

**FIGURE 12**  
Ranger Live-Loaded Packing Design

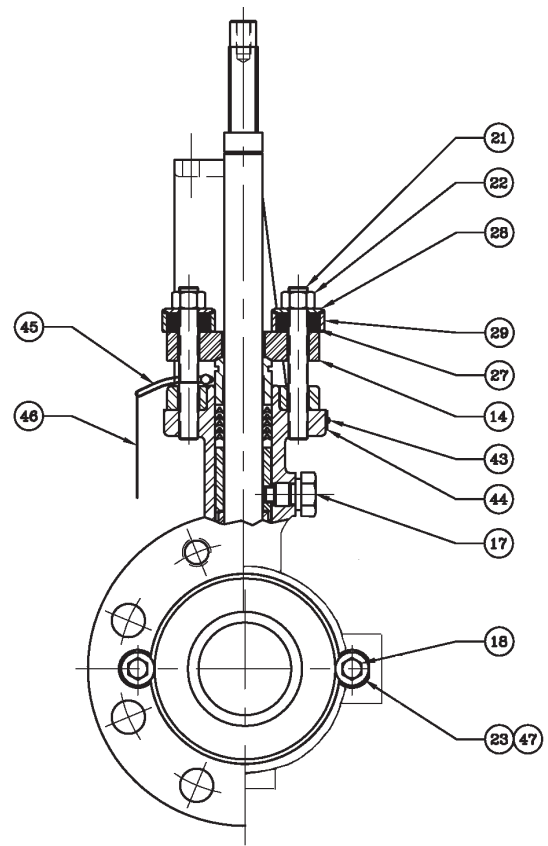


Item No.	Part Description
14	Packing Flange
15	Packing Follower Assy.
15.1	Follower
15.2	Carbon Bushing ‡

**FIGURE 13**  
Ranger Live-Loaded Packing with Opt-38HT  
High Temperature Packing Design



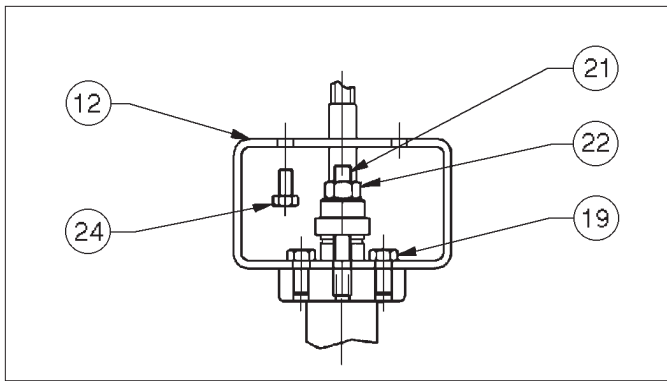
BA – Body Assembly - Side View -  
Std. Flow Direction



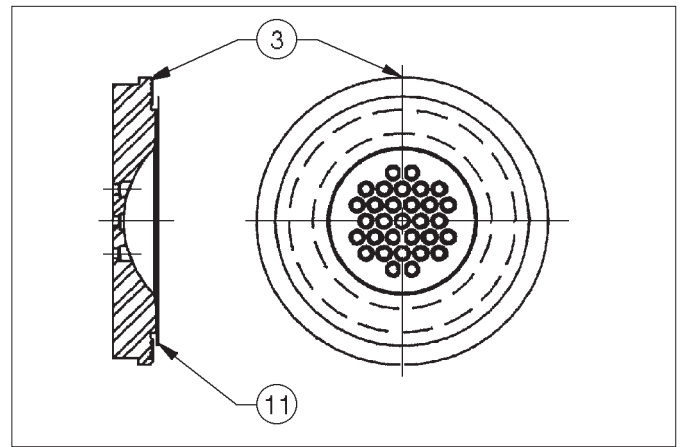
Integral Flanged      Flangeless  
BA – Body Assembly - Front View

Item No.	Part Description	Item No.	Part Description
1	Body	21	Stud (Packing Flange)
2	Cage	22	Nut (For Short Studs & Packing Flange Studs)
3	Seal Retainer	23	Washer
4	Bearing (Long)	24	Cap Screw (For Mtg. to Actuator)
5	Bearing (Short)	25	Low Noise Insert
6	Plug	26	Abrasion Sleeve
7	Stem Subassembly	27	Washer (Belleville)
8	Retainer Sleeve Subassembly	28	Retainer (Washer)
9	Seal Retainer Gasket ‡	29	Spacer (Live Loaded Packing)
10	Seal (Soft) ‡	30	O-Ring ‡
11	Seal (Metal) ‡	31	Backup Ring ‡
12	Yoke	32	Tie Bolt
13	Packing Ring Set ‡	33	Nut (used with Tie Bolt)
14	Packing Flange	43	Drive Screw (Flanged Ranger)
15	Packing Follower	44	Flow Arrow (Flanged Ranger)
16	Follower Bushing Strip ‡	45	Security Seal
17	Stem Retainer Screw	46	“Caution” Plate
18	Hex Head Cap Screw (Seal Retainer Screw)	47	Belleville Washer
19	Hex Head Cap Screw (1", 1-1/2", 2" Ranger & 8'HF Ranger)		
20	Stud (Short) (3", 4", 6", 8" Ranger)	‡	Recommended Spare Part

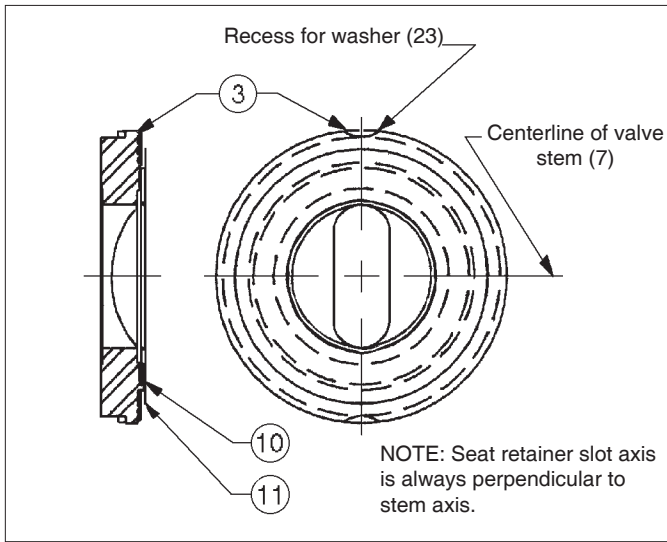
**FIGURE 14**  
Body Assembly



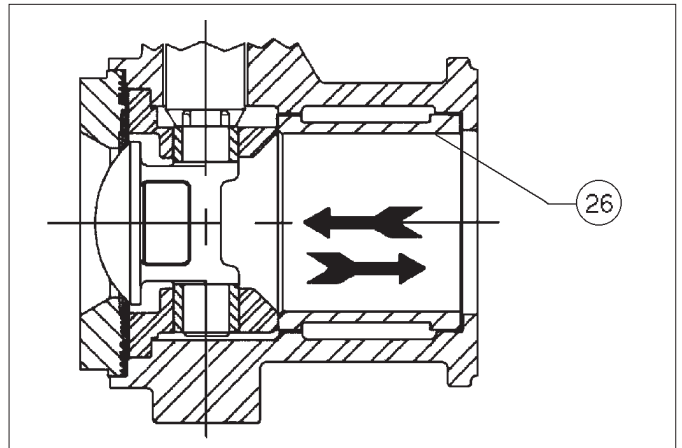
**FIGURE 15**  
1", 1-1/2" & 2" Yoke



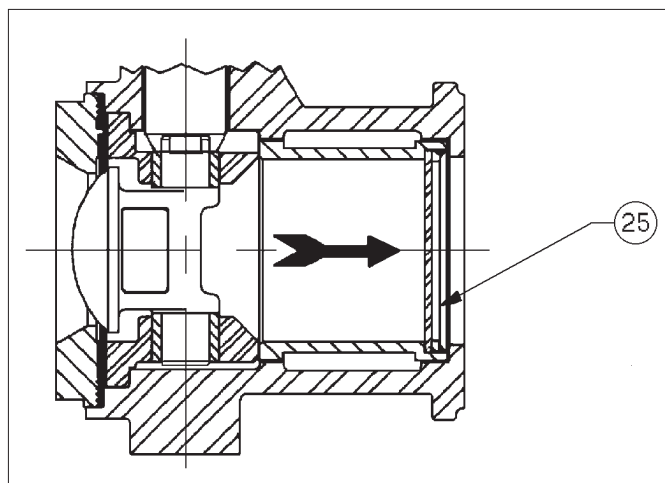
**FIGURE 16**  
Anti-Cavitation Seal Retainer or  
LNA/D Lo-Noise Seal Retainer



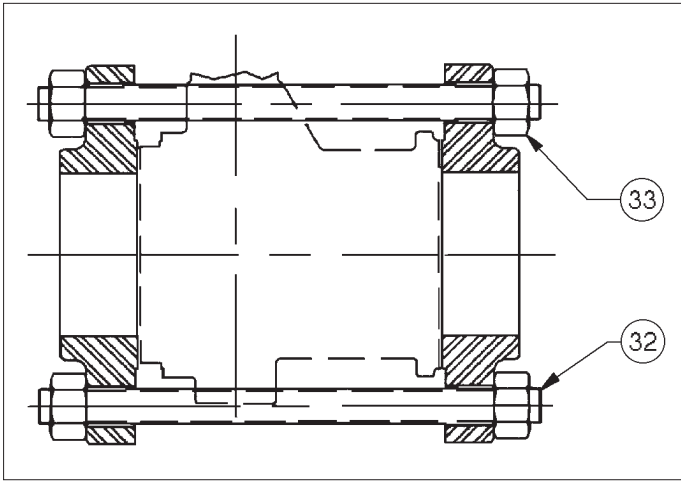
**FIGURE 17**  
Reduced Trim Seal Retainer



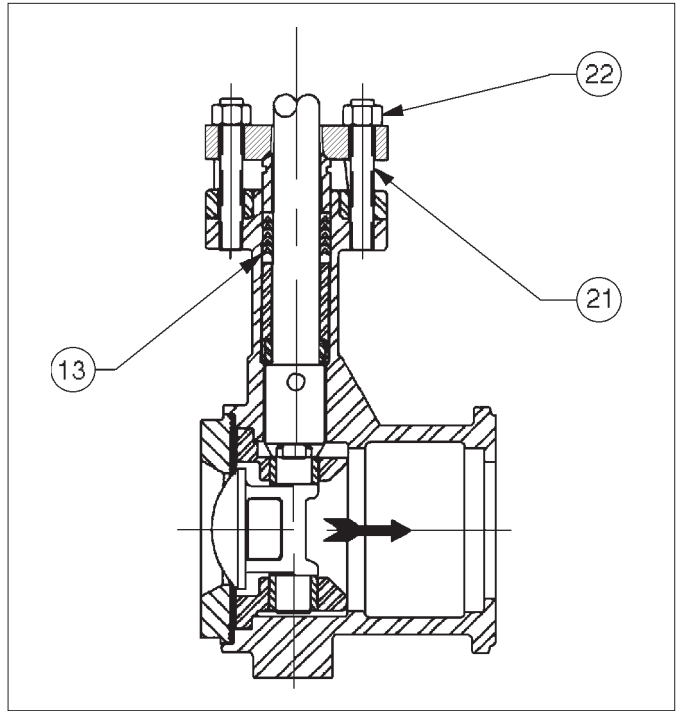
**FIGURE 18**  
Abrasion Sleeve



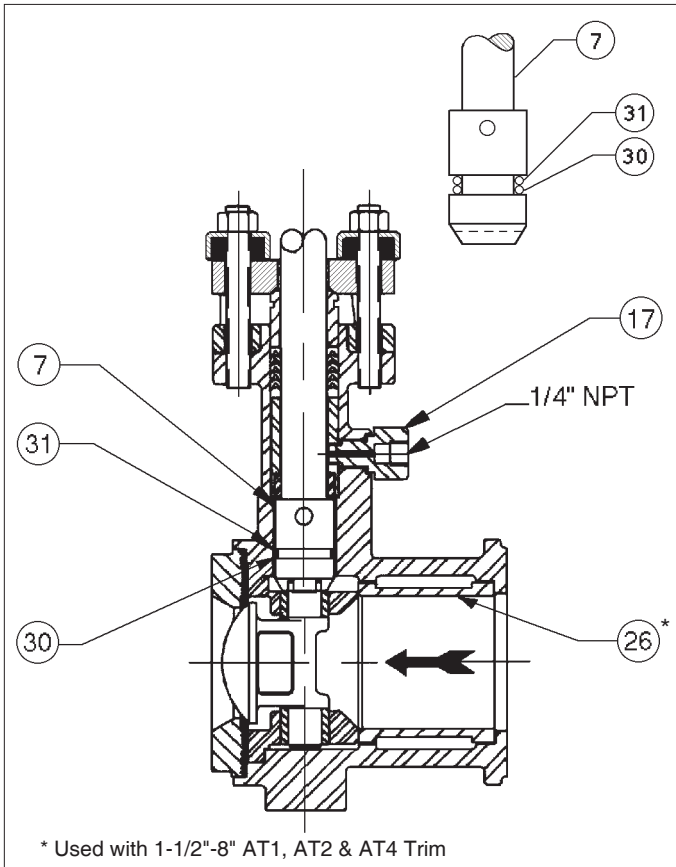
**FIGURE 19**  
LN2 - LN4 Lo-Noise Insert



**FIGURE 20**  
Ranger Control Valve Line Bolting

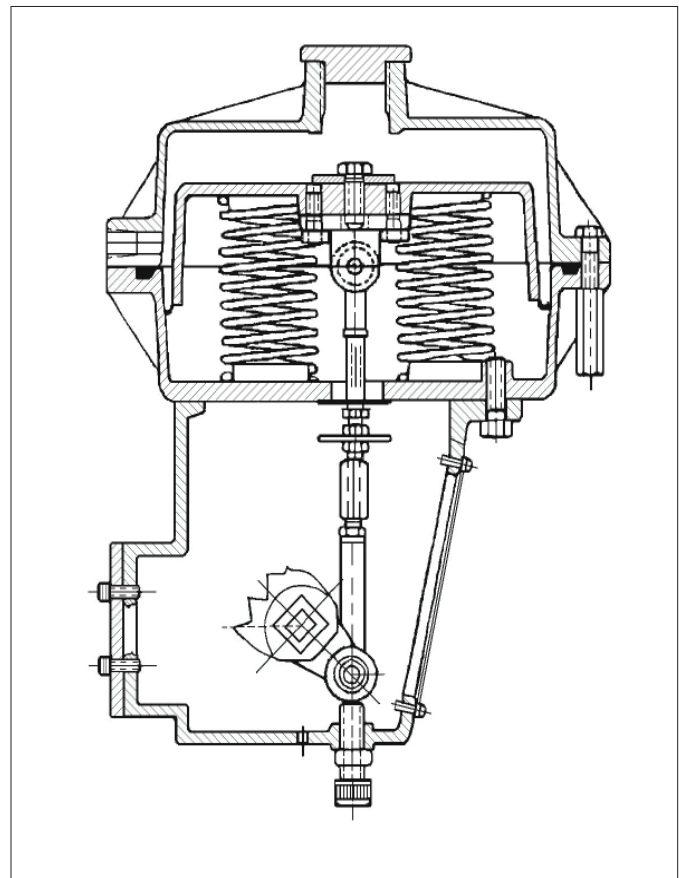


**FIGURE 22**  
Jammed Packing



\* Used with 1-1/2"-8" AT1, AT2 & AT4 Trim

**FIGURE 21**  
Slurry Trim



**FIGURE 23**  
ATC-FO Actuator Without Handwheel Assy.



IOM ADDENDUM:

ATEX DIRECTIVE 2014/34/EU and THE EQUIPMENT AND PROTECTIVE SYSTEMS INTENDED FOR USE IN POTENTIALLY EXPLOSIVE ATMOSPHERES REGULATIONS 2016

Cashco, Inc. declares that the products listed in the table below has been found to comply with the Essential Health and Safety Requirements relating to the design and construction of products intended for use in potentially explosive atmospheres given in Annex II of the ATEX Directive 2014/34/EU and given in Schedule 1 of The Equipment and Protective Systems Indented for Use in Potentially Explosive Atmospheres Regulations 2016. Compliance with the Essential Health and Safety Requirements has been assured by compliance with EN ISO 80079-36:2016 and EN ISO 80079-37:2016. The product will be marked as follows:



The 'X' placed after the technical file number indicates that the product is subject to specific conditions of use as follows:

1. The maximum surface temperature depends entirely on the operating conditions and not the equipment itself. The combination of the maximum ambient and the maximum process medium temperature shall be used to determine the maximum surface temperature and corresponding temperature classification, considering the safety margins described prescribed in EN ISO 80079-36:2016, Clause 8.2. Additionally, the system designer and users must take precautions to prevent rapid system pressurization which may raise the surface temperature of system components and tubing due to adiabatic compression of the system gas. Furthermore, the Joule-Thomson effect may cause process gases to rise in temperature as they expand going through a regulator. This could raise the external surface temperature of the regulator body and the downstream piping creating a potential source of ignition. Whether the Joule-Thomson effect leads to heating or cooling of the process gas depends on the process gas and the inlet and outlet pressures. The system designer is responsible for determining whether the process gas temperature may raise under any operating conditions.
2. Where the process medium is a liquid or semi-solid material with a surface resistance in excess of  $1G\Omega$ , special precautions shall be taken to ensure the process does not generate electrostatic discharge.
3. Special consideration shall be made regarding the filtration of the process medium if there is a potential for the process medium to contain solid particles. Where particles are present, the process flow shall be  $<1\text{m/s}$  ( $<3.3\text{ft/s}$ ) in order to prevent friction between the process medium and internal surfaces.
4. Effective earthing (grounding) of the product shall be ensured during installation.
5. The valve body/housing shall be regularly cleaned to prevent build up of dust deposits.
6. Regulators must be ordered with the non-relieving option (instead of the self-relieving option) if the process gas they are to be used with is hazardous (flammable, toxic, etc.). The self-relieving option vents process gas through the regulator cap directly into the atmosphere while the non-relieving option does not. Using regulators with the self-relieving option in a flammable gas system could create an explosive atmosphere in the vicinity of the regulator.
7. Tied diaphragm regulators with outlet ranges greater than 7 barg (100 psig) should be preset to minimize the risk that improper operation might lead to an outboard leak and a potentially explosive atmosphere.
8. All equipment must only be fitted with manufacturer's original spare parts.
9. Ensure that only non-sparking tools are used, as per EN 1127-1, Annex A.

	PRODUCT
<b>REGULATORS</b>	31-B, 31-N
	1164, 1164(OPT-45)
	1171, 1171(OPT-45), 1171(CRYO)
	2171, 2171(OPT-45), 2171(CRYO), 3171
	1465, 3381, 3381(OPT-45), 3381(OPT-40)
	4381, 4381(OPT-37), 4381(CRYO), 4381(OPT-45), 5381
	MPRV-H, MPRV-L
	PBE, PBE-L, PBE-H
	CA-1, CA-2
	CA1, SA1, CA4, SA4, CA5, SA5
	DA2, DA4, DA5, DA6, DA8
	DA0, DA1, DAP, SAP
	SLR-1, SLR-2, PTR-1
	ALR-1, ULR-1, PGR-1
	BQ, BQ(OPT-45), BQ(CRYO)
	123, 123(CRYO), 123(OPT-45), 123(OPT-46G)
	123-1+6, 123-1+6(OPT-45), 123-1+6(OPT-46G), 123-1+6+S, 123-1+6+S(OPT-40)
	1000HP, 1000HP(OPT-37), 1000HP(OPT-45), 1000HP(OPT-45G), 1000HP(CRYO)
	1000HP-1+6, 1000HP-1+8, 1000LP, 1000LP(OPT-45), 1000LP(OPT-46G)
	6987
	8310HP, 8310HP-1+6, 8310HP-1+8, 8310LP, 8311HP, 8311LP
	345, 345(OPT-45)
	BA1/BL1, PA1/PL1
	C-BPV, C-PRV, C-CS
	D, D(CRYO), D(OPT-37), D(OPT-20), D(OPT-45)
	DL, DL(LCC), DL(OPT-45)
	BR, BR(CRYO)
	HP, HP(LCC), HP(OPT-45), HP(OPT46G), HP-1+6+S(OPT-40), HP-1+6+S
	P1, P2, P3, P4, P5, P7
	B2, B7
	POSR-1, POSR-2
	5200P, 5300P
	135
NW-PL, NW-SO	
CG-PILOT	
FG1	
<b>CONTROL VALVES</b>	RANGER, 987, PREMIER
	964, 521, 988, 988-MB, 989
	2296/2296HF
	SCV-30, SCV-S
<b>TANK BLANKETING</b>	8700, 8910, 8920, 8930, 8940
	2100, 2199
	3100, 3200, 3300, 3400, 3500, 3600, 3700
	1078, 1088, 1100, 1049
	5100, 5200, 5400, 5500
	4100, 4200, 4300, 4400, 4500, 4600
<b>MISC</b>	764P/PD, 764-37, 764T



**Valve  
& Automation**  
Total Valve & Control Solutions®

**JOHANNESBURG**

Tel: 011 397 2833

**DURBAN**

Tel: 031 579 2593

**South Africa:**

**0861 103 103**

E-mail: [sales@valve.co.za](mailto:sales@valve.co.za)

[www.valve.co.za](http://www.valve.co.za)



SCAN ME