



# MODEL 48

## SPRING/DIAPHRAGM ROTARY ACTUATORS

### SECTION I

#### I. DESCRIPTION AND SCOPE

Models 48D and 48R are multi-spring, single acting, spring opposed, rotary actuators used with Cashco rotary control valves. Regardless of final installed failure action, the actuator is always pressurized on “top” of the traveling diaphragm plate.

Cashco has adopted a convention as follows in identifying its rotary actuators:

- “D” = Direct Action = ATC-FO Action
- “R” = Reverse Action = ATO-FC Action

The Model 48 actuator is field reversible by arrangement of actuator with respect to valve stem and valve plug/disc orientation. Some disassembly is required, but no new parts are required.

Reference the technical bulletin of the valve body these actuators are unitized with for operating/installation/selection specifications; i.e. available bench settings, strokes, etc.

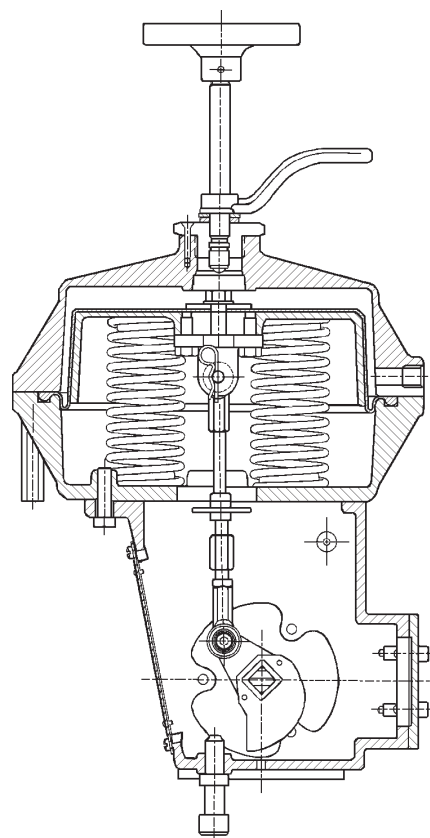

**Figure 1**  
**Model 48 Actuator**

### SECTION II

#### II. MODEL NUMBERING

The basic Model Number identifies the actuator size and action. To identify a unique Model Number, another series of 2-character modifiers is added to the basic number. This number will identify which basic valve body the actuator may be used on. See Table 1.

**TABLE 1**

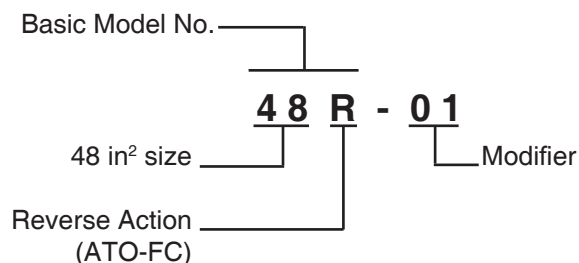

<u>Valve Product</u>	<u>Modifier Series No.</u>
Ranger QCT	-00 through -09
Premier EZO	-00 through -09
Premier Unlined	-00 through -09

**ACTUATOR MODEL NO. vs. VALVE BODY MODEL**  
(Model 148 included for clarity)

Full Actuator Model No.		Available Bench Settings		Air Supply Pressure		Unitized Products *
Basic Actuator Model No.	Modifier Number	psig	(Barg)	psig	(Barg)	
48R or 48D	-01	5-15	(.34-1.03)	20	(1.4)	1"-2" (DN25-50) Ranger QCT 3"-4" (DN80-100) Premier EZO or Premier Unlined
148R or 148D	-01	5-13	(.34-0.90)	20	(1.4)	3"-4" (DN80-100) Ranger QCT 6" (DN150) Premier EZO or Premier Unlined
148R or 148D	-02	10-26	(.69-1.79)	36	(2.5)	4"-8" (DN100-200) Ranger QCT, 10" (DN250) Premier EZO
148R or 148D	-03	7.5-19.5	(.52-1.34)	27	(1.9)	8" (DN200) Premier EZO, 8"-10" (DN200-250) Premier Unlined

\* Metric body size in parenthesis.

**SECTION III**

**III. INSTALLATION**

**A. Orientation:**

1. Recommended actuator major axis orientation with any model of Cashco rotary control valve is upwards with the valve in a horizontal pipe and the valve stem also horizontal; i.e. position "A" for ATO-FC, or position "B" for ATC-FO.
2. Both Ranger QCT and Premier EZO/Unlined control valve products incorporate an extended

valve body bonnet and a mounting yoke to allow the actuator to be far enough away from the valve body or mounting flanges to incorporate a minimum of 2" (50 mm) thickness of insulation. It should not be necessary to install thermal insulation to any portion of Model 48 actuator. The maximum ambient temperature for installation is 180°F (83°C); the minimum ambient temperature is -20°F (-29°C).

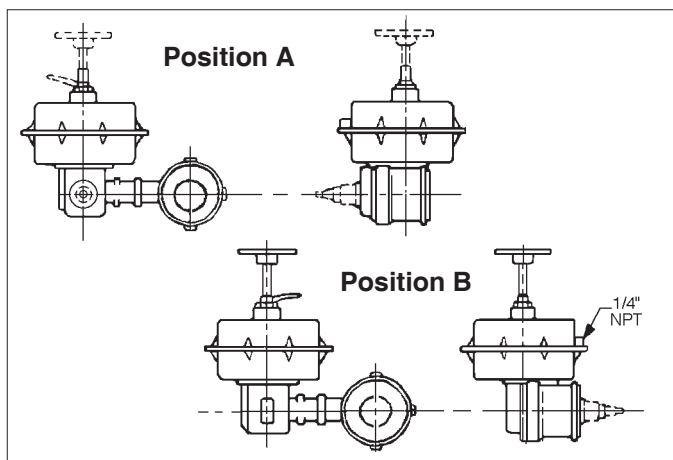

**FIGURE 2:** Mounting position of Ranger QCT to Model 48 Actuator with Model 73N-B P/P Positioner.

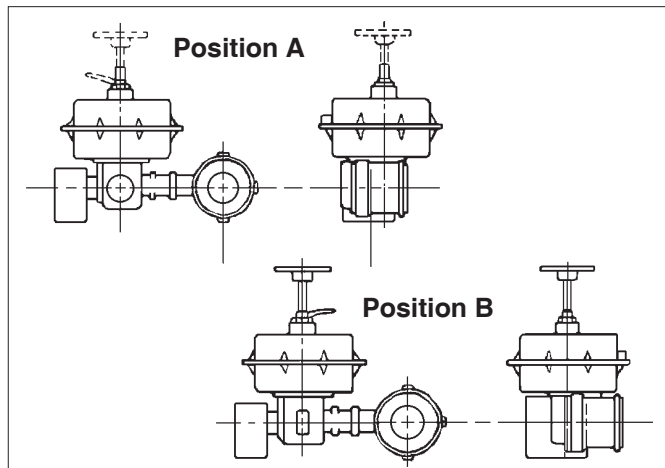

**FIGURE 3:** Mounting position of Ranger QCT to Model 48 Actuator w/Model 9540R or Smart Positioners.

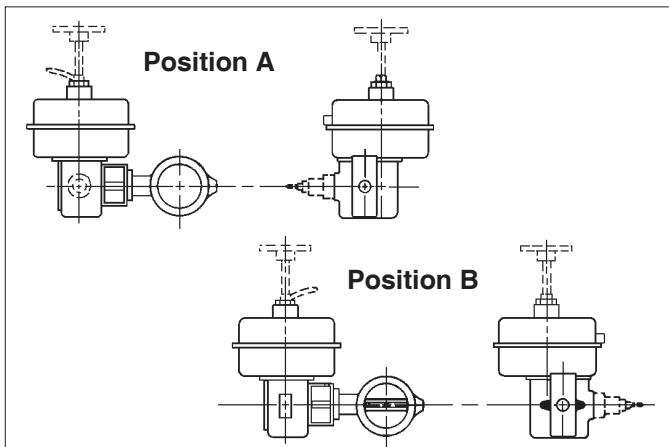

**FIGURE 4:** Mounting position of Premier EZO or Premier Unlined to Model 48 Actuator with Model 73N-B P/P Positioner

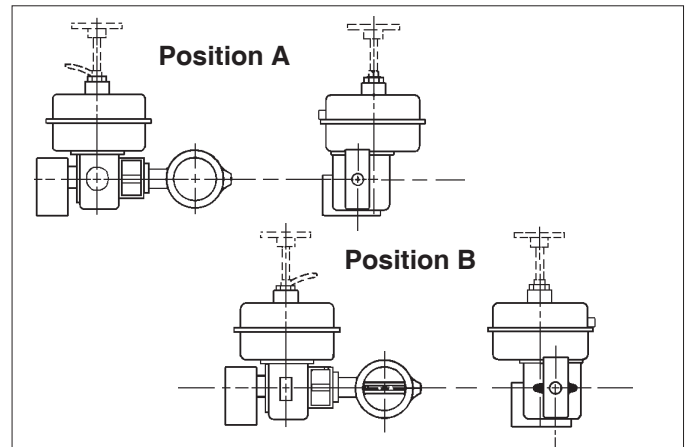

**FIGURE 5:** Mounting position of Premier EZO or Premier Unlined to Model 48 Actuator with Models 9540R or Smart Positioners

3. A 1/4"–NPT female connection for pneumatic LOAD is located on the side of the actuator's upper diaphragm casing near the casing flange joint. Reference specific Ranger-TB or Premier-TB for location of the connection.
4. Reference the valve body instructions — IOM-Ranger, IOM-Premier EZO or IOM-Premier Unlined — for additional instructions on installing unit in the process piping.

#### B. Air Supply:

1. Recommendation is that a desiccant dried, instrument quality air supply be used. Such a supply is recommended for outdoor installations, and is required in areas of freezing weather conditions.

2. If air supply contains moisture and/or lubricating oil, the air should be filtered with a coalescing type of filter prior to use in stroking the actuator.
3. Connection for the air loading pressure is 1/4" female NPT. A suitable pipe thread sealant is recommended to be used when installing the pipe or tube fitting. Exhibit care to prevent the sealant from getting inside the tube/pipe.
4. If an alternate gaseous fluid is used as a source of loading pressure (i.e. natural gas, nitrogen, etc.), this gas MUST NOT BE CORROSIVE to the aluminum casing material.

## SECTION IV

### IV. OPERATION

#### A. General:

1. Actuators supplied with 5-13 psig (0.34-0.90 Barg) benchset range are designed to operate with or without a positioner. A 3-15 psig (0.21-1.03 Barg) instrument output signal would be required to operate without a positioner.
2. On larger valve body sizes the benchset range is essentially 1.5–2.3 times that of the 5-13 psig (0.34-0.90 Barg); i.e. 7.5-19.5 psig (0.52-1.34 Barg) or 10-26 psig (0.69-1.79 Barg) for Model 148's. Either a signal booster or a positioner will be required for full rotation (0°–90°) by the actuator.
3. If an "installed characteristic" other than the "inherent characteristic" is desired, a positioner plus a "characterization cam" is required. The inherent characteristic of Ranger QCT control valves is linear; for Premiers the inherent characteristic is equal percent.
4. See Tables 2 through 4 for available actuator models with benchset ranges per valve type and body size. (**Note:** Model 148 actuators included for clarity.) Proper **MAXIMUM** air supply pressures are also indicated.

**TABLE 2  
RANGER QCT  
ACTUATOR BENCHSET RANGES**

Valve Body Size In. (DN)	Actuator Model *	Failure Action	Benchset Range psig (Barg)	Supply Pressure psig (Barg)	Qty of Range Springs
1", 1-1/2" & 2" (25, 40 & 50)	48R-01	ATO-FC	5-15	20 (1.4)	6
	48D-01	ATC-FO	(.34-1.03)		
3" & 4" (80 & 100)	148R-01	ATO-FC	5-13	20 (1.4)	4
	148D-01	ATC-FO	(.34-.90)		
4", 6" & 8" (100,150, & 200)	148R-02	ATO-FC	10-26	36 (2.5)	8
	148D-02	ATC-FO	(.69-1.79)		

**TABLE 3  
PREMIER EZO  
ACTUATOR BENCHSET RANGES**

Valve Body Size In. (DN)	Actuator Model *	Failure Action	Benchset Range psig (Barg)	Supply Pressure psig (Barg)	Qty of Range Springs
3" & 4" (80 & 100)	48R-01	ATO-FC	5-15	20 (1.4)	6
	48D-01	ATC-FO	(.34-1.03)		
6" (150)	148R-01	ATO-FC	5-13	20 (1.4)	4
	148D-01	ATC-FO	(.34-.90)		
8" (200)	148R-03	ATO-FC	7.5-19.5	27 (1.9)	6
	148D-03	ATC-FO	(.52-1.34)		
10" (250)	148R-02	ATO-FC	10-26	30 (2.1)	8
	148D-02	ATC-FO	(.69-1.79)		

**TABLE 4  
PREMIER UNLINED  
ACTUATOR BENCHSET RANGES**

Valve Body Size In. (DN)	Actuator Model *	Failure Action	Benchset Range psig (Barg)	Supply Pressure psig (Barg)	Qty of Range Springs
3" & 4" (80 & 100)	48R-01	ATO-FC	5-15	20 (1.4)	6
	48D-01	ATC-FO	(.34-1.03)		
6" (150)	148R-01	ATO-FC	5-13	20 (1.4)	4
	148D-01	ATC-FO	(.34-.90)		
8", 10" (200, 250)	148R-03	ATO-FC	7.5-19.5	27 (1.9)	6
	148D-03	ATC-FO	(.52-1.34)		

\* Model 148 included for clarity.

## SECTION V

### V. MAINTENANCE

#### A. General:

1. Hereafter, all maintenance, disassembly, etc., is assumed to be done in an indoor shop.
2. Most actuators are a sub-assembly that is unitized with a body sub-assembly. Reference should be made to the IOM for the correct body utilized.
3. Where the body is not being disassembled, special care **MUST** be exhibited to prevent valve stem rotation during any disassembly or reassembly for all types of valves. Following this procedure will ensure not damaging seating surfaces.
4. Remove all instrument tubing and interconnected electrical wiring. Label "ends" to ensure proper reconnection.
5. All indicated Item Numbers that are with respect to IOM-Ranger, IOM-Premier EZO or IOM-Premier Unlined will be in parenthesis and underscored; i.e. (20); the same is true for Model 73N-B P/P positioner parts.
6. All Item Numbers that are with respect to this IOM-48 are not underscored; i.e. (19).
7. Item Numbers that relate to the Model 9540 or Smart positioners ((PA)) are in a double set of parenthesis and are underscored; i.e. ((3)).

#### B. Separation of Body Assembly (BA) from Actuator Assembly (AA):

1. Place completely joined valve assembly (AA) (BA) upon a flat work surface with sufficient room to move the individual sub-assemblies (AA) (BA) around. Place matchmarks on valve yoke (12), arm housing (4) and actuator lower casing (2) to use as references.
2. Remove cover plate (20) away from arm housing (4) by removing four machine screws (36).

#### 3A. Units with Model 73N-B P/P Positioner or No Positioner, and No Travel Limit Switch:

- a. Using a 3/16" allen key wrench, remove the three cap screws (31) securing the dial lens (14), travel indicator dial (15) and coverplate (13).
- b. Remove cap screw (32) and lock tooth

washer (55) securing the bright orange-colored travel indicator (16) to the upper end of valve stem (Ranger (7)), (Premier (3.2)) using a 7/32" allen key wrench. Remove travel indicator (16) off of protruding locator pin (51).

- c. If equipped with a Model 73N-B P/P positioner, remove the four cap screws (33) that secure the positioner assembly (PA) to the arm housing (4) using a 3/16" allen key wrench. Remove positioner assembly (PA) and feedback range spring (102). Loop a 6" piece of fine wire around the feedback linkage subassembly (72). Place one screw (33) back into a tapped opening. Pull wire taut and wrap around protruding screw (33) to keep the linkage (72) from interfering with further disassembly.

#### 3B. Units with End-of-Shaft Model 9540R Positioners:

- a. Remove clear indicator cover ((22)) by removing two cap screws ((A3)).
- b. Remove red plastic pointer ((34)) by pulling outwards from hub of post-end screw ((23)).
- c. Make a matchmark on the characterization cam ((24)) at the point where the cam follower ((31)) touches. Using a wrench remove post-end screw ((23)) that secures characterization cam ((24)). Pull feedback lever ((13)) downwards; remove cam ((24)) and adhered to lock toothed washer ((28)) and shouldered washer ((27)).
- d. Remove the positioner unit ((I/P)) ((P/P)) from the baseplate ((26)) by removing cap screws ((11)) with lock washers ((12)) from side and back of baseplate ((26)).
- e. Remove the four cap screws ((78)) securing the bracket ((76)), baseplate ((26)) assembly and coverplate (13) to the arm housing (4).

#### 3C. Units with End-of-Shaft Model 991 or PS2 I/P Positioners:

- a. Remove cap screws (31) securing the positioner mounting bracket ((9)) to coverplate (13).
- b. Set positioner/bracket assembly to the side.
- c. Remove set screw ((16)), washer ((17)) from end of valve stem (Ranger (7)), (Premier (3.2)) securing carrier linkage ((3)) to stem.
- d. Remove linkage ((3)) from end of stem.

4. For ATO-FC valve action, it is necessary to remove the “stem windup”.
  - a. Rotate manual handwheel operator (MHW) handwheel (58.1) approximately 1-3 revolutions CW (viewed from above handwheel) until interconnecting arm and stem linkage (5, 10) of actuator “relax”.
  - b. Pressurize actuator casing (1) only until the interconnecting arm and stem linkage (5,10) “relax”. **DO NOT OVER-PRESSURIZE.**

**NOTE:** Do not remove the drive coupling ((32)) unless required.

5. Remove ball bearing (18), both bearing flanges (19) and indicator spacer (17) over shaft-end (Ranger (7)), (Premier (3.2)).
6. For actuator with a handwheel (58), rotate handwheel CW (viewed from above), driving the arms (5) down until the shoulder bolt (40) clears the ears on the arm housing (4). If actuator does not include a handwheel (58), loosen jam nut (44) and, using a 9/16" open end wrench, rotate the hex portion of the push rod (10) until the shoulder bolt (40) clears the ears on the arm housing (4).
7. Remove lock nut (46) that secures shoulder bolt pin (40) through lever arms (5). Remove shoulder bolt pin (40).
8. Grasp lever arms and rotate stem (Ranger (7)), (Premier (3.2)) as required to pull down and away from the lower rod end-L.H. (9) to allow clearance to remove arms (5). Slide subassembly consisting of both arms (5), spacer (12) or characterization cam (Model 73N-B (12)), and two spring pins (50) outwards and away from the arm housing (4) and over shaft-end (Ranger (7)), (Premier (3.2)).
9. While securely holding the actuator assembly (AA) with an overhead sling support, and the body assembly (BA) to prevent movement, remove the four bolts (24) that secure the body yoke (12) to the actuator arm housing (4). Slide the actuator assembly (AA) over the stem-end (Ranger (7)), (Premier (3.2)). Lay body assembly (BA) aside.

**C. Changing Actuator Mounting Position (With No Change in Failsafe Action).**

1. Determine the desired mounting position of actuator assembly (AA) with respect to

valve body assembly (BA) from Figures 6-9, following pages.

2. The valve body/bonnet (1) to valve body yoke (12) can be rotated in four 90° increments around the centerline of the valve shaft (Ranger (7)) (Premier (3.2)).
3. Separate the actuator assembly (AA) from the body assembly (BA) as described in this Section, V.B.1. through V.B.9.
4. Determine if it is necessary to interchange packing studs (21) on Ranger or Premier Unlined, and yoke (12) attachment hex head cap screws (19) on Ranger or Premier Unlined per following:

Rotary Valve	Degrees Rotation Position Change	Packing Studs Yoke Attach Studs Switch of Position
Ranger, Premier Unlined	90°, 270°	Required
Premier EZO	180°	Not Required
	90°, 180°, 270°	Not Required

5. If required, remove both packing flange stud nuts (22) on Ranger or Premier Unlined, and any external live-loaded packing components (Ranger (27) (28) (29)), and set both aside carefully to prevent an “inadvertent mixing” of the component’s “stack-up”.
6. Place matchmarks between yoke (12) and valve bonnet/body (1). While holding yoke (12) with hand, remove two cap screws (19) and pull yoke (12) over end of stem (Ranger (7)) (Premier (3.2)) and set aside.
7. If necessary, remove studs (21) from Ranger or Premier Unlined body assembly (BA) and relocate/interchange as required.
8. Reposition yoke (12) back onto body bonnet (1), shifted/rotated the number of degrees required (i.e. 90°, 180° or 270°), using the matchmarks to guide to correct position. Secure yoke (12) to body bonnet (1) by engaging two cap screws (19). Torque per following:
  - 1" & 2" Rangers — 35-40 ft-lbs (47-54 N-m)
  - 3" & 4" Premiers, lined & unlined — 75-80 ft-lbs (101-108 N-m).
9. Reposition packing flange (Ranger (14)) (Premier Unlined (5)) over packing studs (21)

**FIGURE 6:  
ORIENTATION – RANGER QCT ACTUATOR MOUNTING POSITIONS  
WITH MODEL 73 P/P POSITIONER**

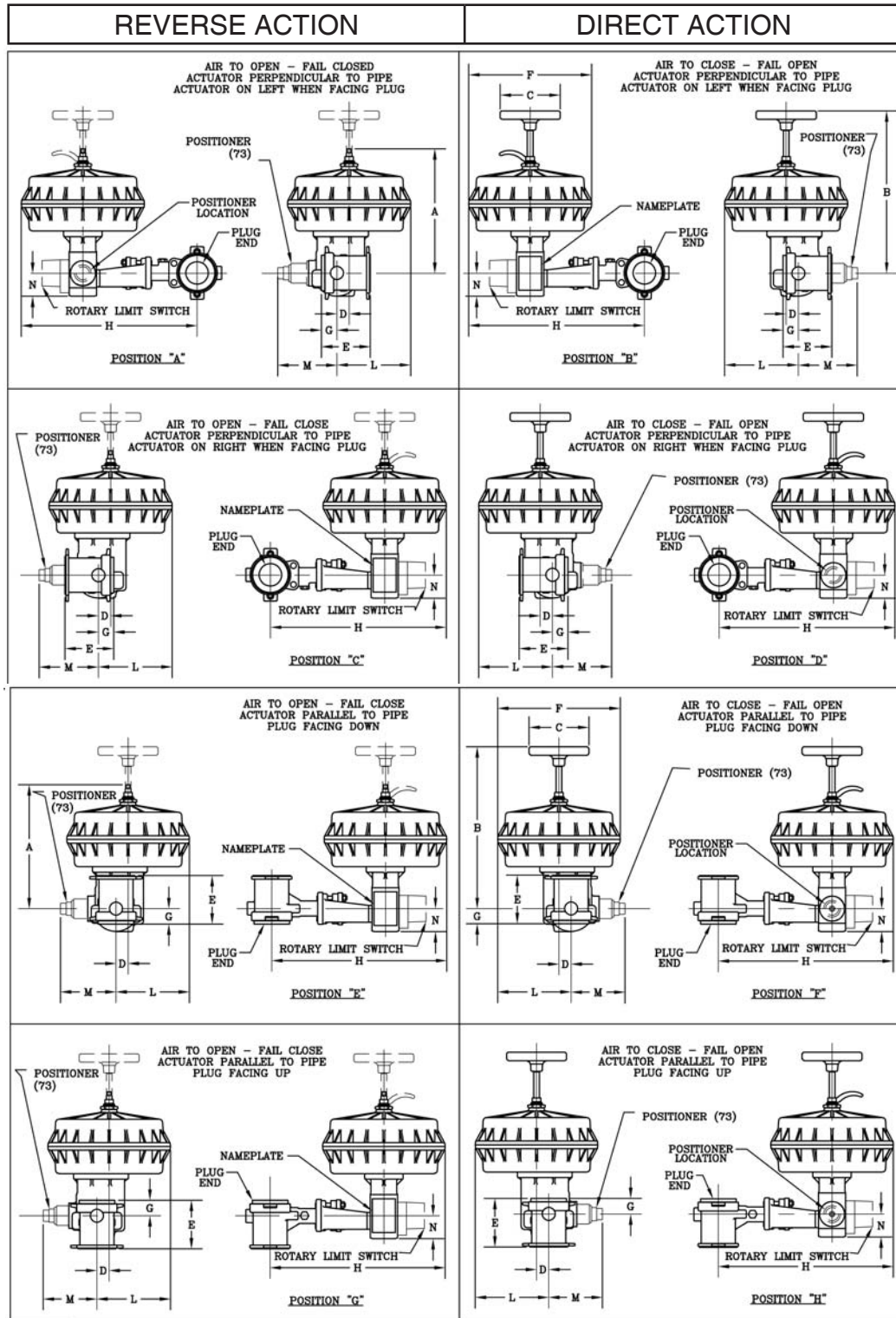

**NOTES:** 1. Flangeless valve design indicated; integral flanged units follow same orientation.  
2. Dimension tables are included in the Ranger-TB.

**FIGURE 7:  
ORIENTATION – RANGER QCT ACTUATOR MOUNTING POSITIONS  
WITH MODELS 9540R P/P or 991 or PS2 I/P POSITIONERS**

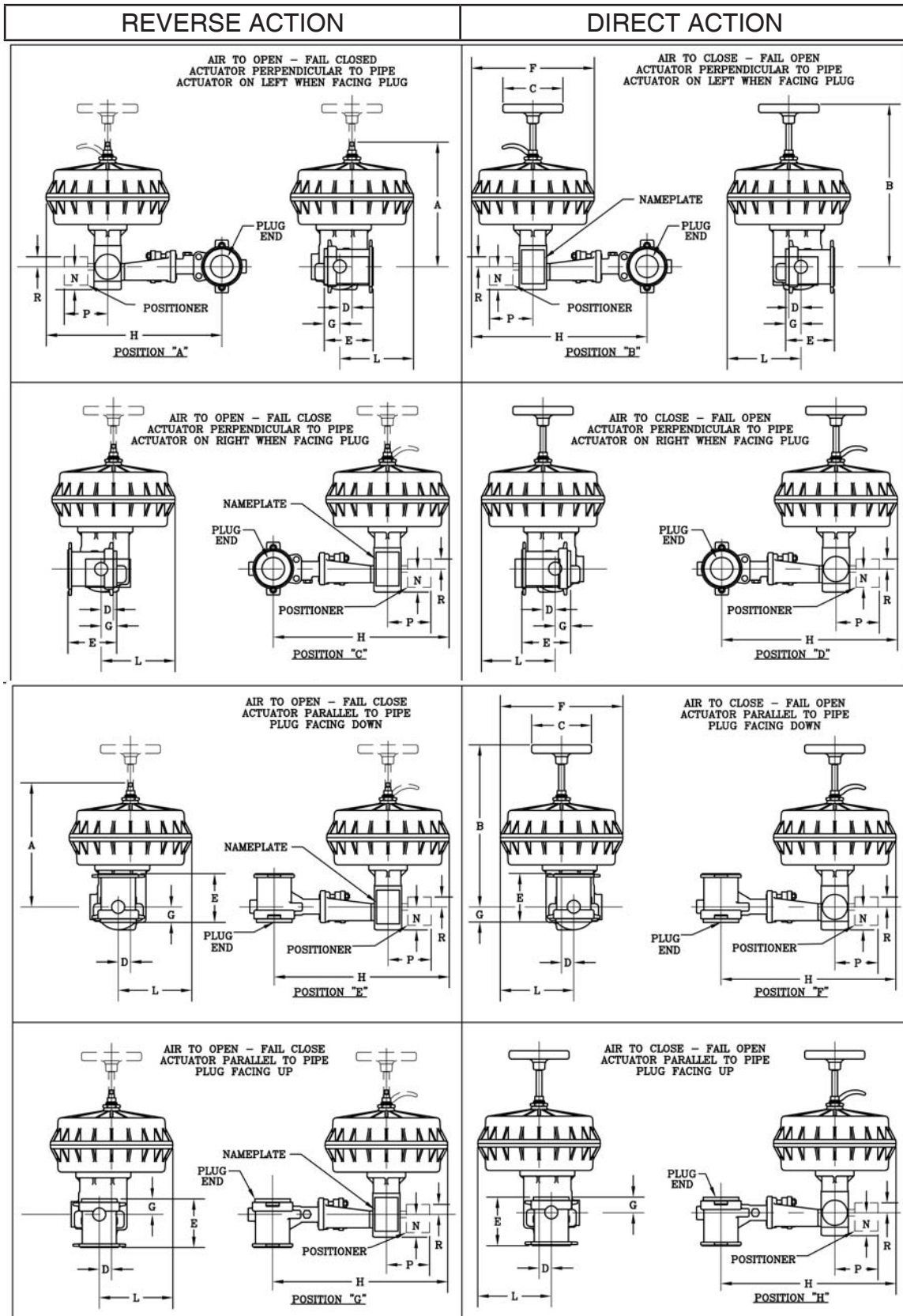

**NOTES:** 1. Flangeless valve design indicated; integral flanged units follow same orientation.  
2. Dimension tables are printed in the Ranger-TB.

**FIGURE 8  
PREMIER ACTUATOR MOUNTING POSITIONS – 73**

Position "A" is standard for fail closed action. Position "B" is standard for fail open action.  
Position "C" and "D" covers vertical piping.

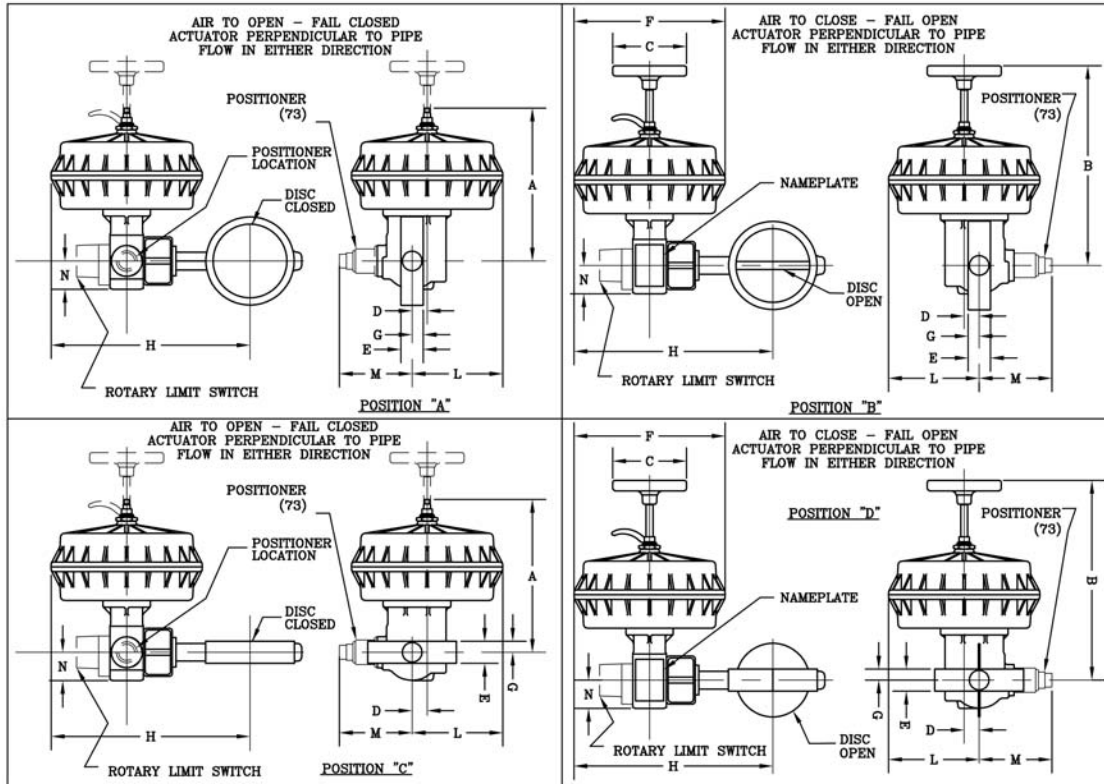

**FIGURE 9  
PREMIER ACTUATOR MOUNTING POSITIONS – 9540R/991/PS2**

Position "A" is standard for fail closed action. Position "B" is standard for fail open action.  
Position "C" and "D" covers vertical piping.

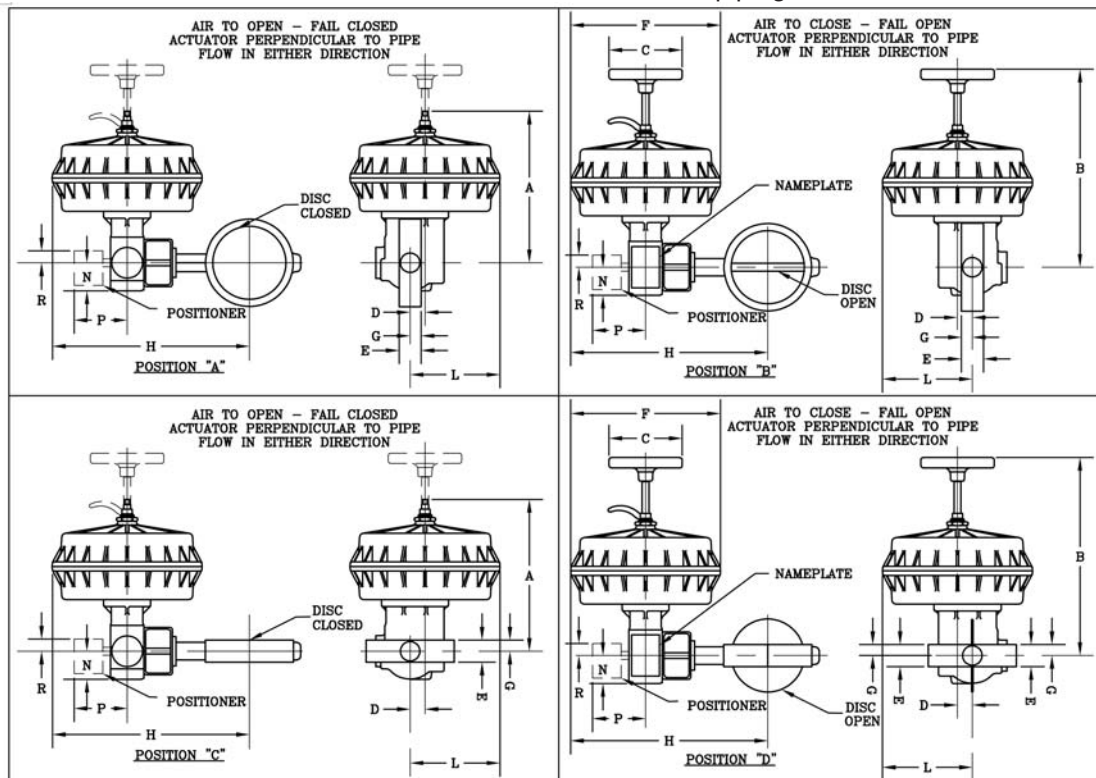

Note: All basic valve dimensions are printed in the Premier-TB

for Ranger and Premier Unlined. Reinstall live-loaded packing components (Ranger (27) (28) (29) 2 sets). Reengage both packing stud nuts (22) for Ranger and Premier Unlined. Set torque level on packing stud nuts as indicated in IOM-Ranger QCT, IOM-Premier EZO, or IOM-Premier Unlined body assembly (BA) instructions.

10. Reorient body assembly (BA) with respect to the actuator assembly (AA). Rejoin the body assembly (BA) to the actuator assembly (AA) as described in this section, V.I. Ensure proper plug (Ranger (6)) or disc (Premier (3.1)) position prior to reinstalling lever arms (5). Ensure that the lever arms (5) are “centered” within the arm housing (4), and with respect to the actuator stem linkage (8) (9) (10) (43) (44).
11. Recalibrate the unit (AA) (BA) and its positioner ((PA)).

**D. Changing Failsafe Action:**

1. The Model 48 actuator (AA) is field-reversible for failsafe action with no additional parts required.
2. It is possible that both of the following can occur together for the degree of disassembly undertaken:
  - a. Failsafe action reversed.
  - b. Change in actuator mounting position.

**NOTE:** This section will be limited to the procedures for 2.a. above. If 2.b. is also desired, then it will be necessary to reference Subsection C. herein for the added procedural steps as required.

This subsection will thus be limited as indicated as follows (reference Figures 6 – 9 herein for beginning and end graphic orientations).

3. To reverse actuator (AA) failsafe action

Product	Begin		End	
	Position	Action	Position	Action
Ranger QCT	“A”	ATO-FC	“B”	ATC-FO
	“C”	ATO-FC	“D”	ATC-FO
	“E”	ATO-FC	“F”	ATC-FO
	“G”	ATO-FC	“H”	ATC-FO
	“B”	ATC-FO	“A”	ATO-FC
	“D”	ATC-FO	“C”	ATO-FC
	“F”	ATC-FO	“E”	ATO-FC
	“H”	ATC-FO	“G”	ATO-FC
Premier EZO or Premier Unlined	“A”	ATO-FC	“B”	ATC-FO
	“C”	ATO-FC	“D”	ATC-FO
	“B”	ATC-FO	“A”	ATO-FC
	“D”	ATC-FO	“C”	ATO-FC

basically requires:

- a. Moving lever arms (5) from left side of valve’s stem (Ranger (7)) (Premier (3.2)) to right side, or vice versa. This is accomplished by removing actuator assembly (AA) from body assembly (BA) and rotating actuator (AA) 180° about the actuator’s stem linkage (8) (9) (10) (43) (44). See Figure 10 and Figure 11.
- b. Rotating plug (Ranger (6)) or disc (Premier (3.1)) by 90°; ie. from “closed” position to “open” position, or vice versa.
- c. Reconnecting actuator (AA) to body (BA) with lever arms (5) also rotated 180°.

**NOTE:** Valve stem always goes CW to “close”, viewed from stem-end.

4. Separate the actuator assembly (AA) from the body assembly (BA) as described in this Section, V.B.1. through V.B.9.
5. Rotate plug (Ranger (6)) or disc (Premier (3.1)) position 90° to new failsafe position.
6. Slide actuator assembly (AA) that has been rotated 180° back over the stem-end (Ranger (7)) (Premier (3.2)). Align bolt holes between arm housing (4) and valve yoke (12).
7. Reengage bolting (24) securing arm housing (4) to yoke (12). Torque bolting (24) to 17-20 ft-lbs (23-27 N-m).
8. Ensure that the reinstalled lever arms (5) are also rotated 180° in the same reference as the actuator assembly (AA) was rotated. (**NOTE:** The repositioned arms (5) will appear to have only changed relative position by 90° in another plane.) Ensure the lever arms assembly (5) is “centered” within the arm housing (4), and with respect to the actuator stem (8) (9) (10) (43) (44).
9. Rejoin the body assembly (BA) to the actuator assembly (AA) as described in this Section, V.I.

**E. Diaphragm Replacement:**

1. Place unit assembly (AA) (BA) onto a flat work bench with actuator upper casing (1) on top side; i.e. handwheel (58), if supplied, on top side.
2. Ensure that all air pressure is released from actuator assembly (AA) casing (1).

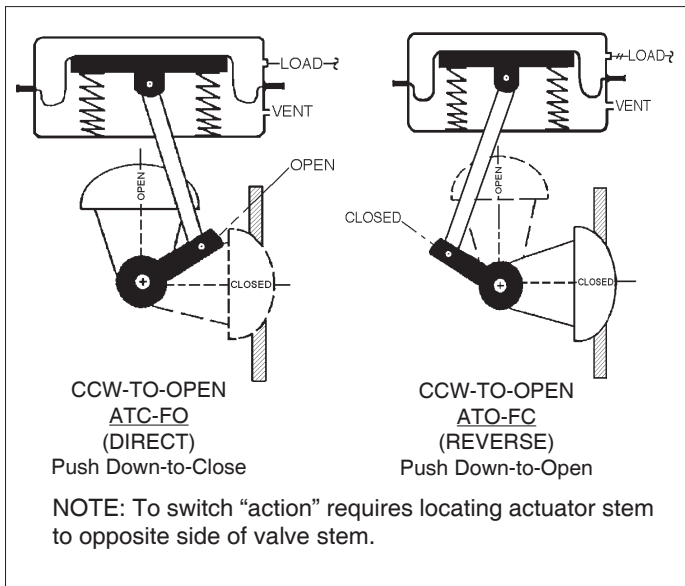

**Figure 10**

Ranger Plug vs. Lever Arm vs. Actuator Orientation

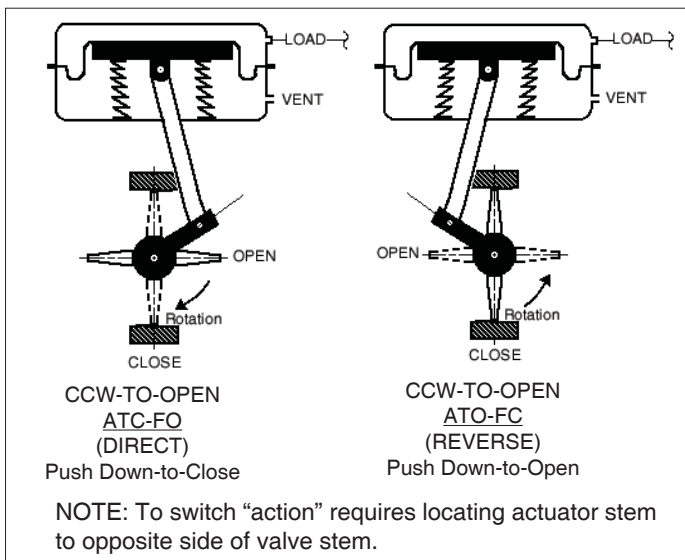

**Figure 11**

Premier Plug vs. Lever Arm vs. Actuator Orientation

3. Ensure that manual handwheel (58) operator is fully rotated upwards by loosening locking lever (59) and rotating CCW (viewed from top side) as far as possible.
4. Place a matchmark between actuator casings (1) (2).

**⚠ WARNING**

**SPRING UNDER COMPRESSION. Prior to removing flange bolting (27, 28, 41, 42) relieve range spring (11) compression by rotating the handwheel or adjusting screw assembly (58) CCW (viewed from above handwheel (58)) until all spring compression is relieved. Failure to do so may result in flying parts that could cause personal injury.**

5. Loosen all casing (1,2) flange bolting (27, 28, 41, 42) two revolutions. Pry apart the casings (1,2) if "stuck" together.
6. In one revolution increments loosen all opposing nuts (41, 42) until the short bolting (27, 41) disengages and can be removed. Continue loosening extension nuts (42) in the alternating, one revolution pattern ensuring that the casings (1, 2) are being "pushed apart", until the extension bolting (28, 42) is disengaged and removed.
7. Lift the upper casing (1) upwards and away from the lower casing (2). Set upper casing (1) aside.
8. Remove pivot screw (25) by rotating CCW (viewed from above), and seal (56).
9. Pry diaphragm washer (52) loose. Clean washer (52) of any rubberized sealant.
10. Prior to diaphragm (6) removal, inspect to see where a diaphragm (6) leak may have been caused by wearing against the upper case (1) at any point. Inspect the upper case (1). **NOTE: The diaphragm (6) is a rolling diaphragm and should NOT touch the upper case (1) at any point of the piston's (3) upwards/downwards travel. If there is side movement of the piston (3), further disassembly for inspection of range springs (11) is mandatory. If there is topside wear, uptravel stop washer (54) is not properly adjusted.**
11. Remove diaphragm (6) and discard.
12. Clean surface of piston (3) of any foreign material that could cause a premature failure of diaphragm (6) if covered. Turn diaphragm (6) "inside-out". Place diaphragm (6) onto piston (3) centered over the center bolt hole in piston (3); ensure that the smooth black surface of diaphragm (6) is on the "pressurized air-side".
13. Place silicone sealant, Dow-Corning "Silastic" #732 RTV or equal, around the diaphragm's (6) center bolt hole opening. Lay diaphragm washer (52) onto sealant and centered over bolt hole. Replace seal (56) on top of washer (52).
14. Place a tool around the skirt circumference of the piston (3) to secure during tightening; use tape or similar material to prevent this tool from leaving sharp edges that could damage the new diaphragm (6). Place Loctite #242, or equal, thread sealant onto the threads of

pivot screw (25); engage and tighten screw (25) to 15-20 ft-lbs (21-27 N-m) torque. **NOTE:** *Piston (3) must be held from rotating to prevent the multiple nested range springs (11) from tilting away from a common vertical centerline between hubs of lower case (2), piston (3) and range spring (11).*

15. Fold the diaphragm (6) skirt from its inside-out orientation, down and around the piston's (3) skirt. Using a rounded-end tool, push the diaphragm (6) down between the lower casing (2) sidewall and the piston's (3) skirt, forming a "valley". Work diaphragm (6) to ensure that all folds or "puckers" are taken away. Press the diaphragm's (6) lower/outer beaded edge into the groove. Again, smooth out all folds or puckers in diaphragm (6).
16. Place a light coating of graphite powder lubricant, (dry molybdenum disulfide) on the skirted areas of diaphragm (6), and into the "valley". This lubricant will prevent the diaphragm (6) from "sticking together" or abrading itself during piston (3) travel.
17. If actuator (AA) is supplied with a manual handwheel operator (MHWO), place a heavy-duty wheel bearing grease, Lubriplate No. 130-AA, or equal, into the v-notch in the head of the pivot screw (25).
18. Inspect working of manual handwheel operator (MHWO) located within the upper casing (1) for signs of wear. Go to Subsection F. for maintenance of manual handwheel operator (MHWO).
19. Place properly oriented upper casing (1) down onto the lower casing (2) with matchmarks aligned and all casing flange bolt holes centered. **NOTE:** *The casing flanges (1) (2) will not touch together.*
20. Insert both extension bolts (28) through two upper casing (1) bolt holes that are located 180° across from each other; these bolts should extend through the lower casing (2) flange enough to engage its companion extension nut (42). Place a friction-reducing thread lubricant on the lower exposed threads of the extension bolts (28).
21. Place the same friction-reducing thread lubricant into the threaded portion of both



## WARNING

1. **Elongated extension bolting (28) (42) is a safety feature to allow relaxation of range springs (11) to the piston's (3) mechanical uptravel stop at disassembly.**
2. **Extension bolting (28) (42) should ONLY be replaced with factory replacements; do NOT substitute conventional bolting.**
3. **Extension bolting (28) (42) MUST be located 180° opposite of each other in the flange bolting array. Failure to heed could cause personal injury at a later disassembly.**

extension nuts (42). **NOTE:** *Only one end of extension nut (42) is threaded. It is not possible to engage the extension bolting (28) (42) with the extension nut (42) upside down; the threads of the nut (42) will not engage.)* Engage both extension nuts (42) until they draw tight to the lower casing (2) flange's underneath side. Place one short bolt (27) through a bolt hole of upper flange (1) to serve as an indicator. In one-revolution increments and an alternating cross-pattern, draw the casing (1) (2) flanges towards each other. When there is at least one-half of the indicator short bolt (27) threads exposed through the lower casing (2) flange, engage nut (41) until the short bolting (27) (41) is finger-tight.

22. Place all short bolts (27) through the remaining upper casing (1) flange bolt holes, and engage each ones nut (41) until the short bolting (27) (41) is finger-tight.
23. In an alternating cross-pattern, tighten all flange bolting (27) (28) (41) (42) in one-revolution increments. When all bolting (27) (28) (41) (42) is hand-wrench tight, torque to levels indicated below:

Item Nos.	Description	Torque Req'd	
		ft-lbs	N-m
27, 41	Short Bolting	15-18	20-24
28, 42	Extension Bolting	8-12	11-16

24. Connect a temporary instrument air source directly to the 1/4" FPT connection in the upper casing (1). Pressurize to the "Air Supply Pressure" level as indicated in Table 2-4 of Section IV.A.4. for the corresponding actual benchset range of the actuator being serviced,

and test for leakage at upper casing (1) to lower casing (2) joint. Also test for leakage at manual handwheel operator (MHWO), rotating handwheel (58) in and out several times during the test.

25. Release all air pressure into actuator upper casing (1); remove air source from 1/4" FPT connection.

#### F. Manual Handwheel Operator:

1. Reference Item Number drawing at end of IOM for details of the manual handwheel operator (MHWO) sub-assembly.
2. Place unit (AA) (BA) on a flat work surface with the handwheel (58) on top side.
3. Ensure all air pressure has been released from actuator casing (1). Ensure handwheel (58) is fully "backed-out" by rotating CCW (viewed from above); i.e. is as "high" as possible.
4. Remove slotted-head screw (65) securing handwheel gland (67) to upper casing (1).
5. Place a smooth-jawed wrench onto handwheel gland (67) and rotate CCW (viewed from above) to removal of the manual handwheel operator sub-assembly (MHWO).
6. Place the sub-assembly (MHWO) into a vise, grasping with leaded jaws on the coarse-screwed handwheel stem (58.2) near the base of the handwheel (58.1), oriented to allow driving-out the rolled pin (66) securing the handwheel (58.1) to the handwheel stem (58.2).
7. Drive pin (66) out using a suitable punch and locking pliers. Set pin (66) aside for reuse. Remove handwheel (58.1) from stem (58.2).
8. Rotate locking lever (59) CCW (viewed from handwheel-end) to removal.
9. Slide washer (60) and threadseal washer (61) off handwheel stem-end (58.2). Discard threadseal washer (61).
10. Remove remaining engaged parts (67) (58.2) from vise. Reorient horizontally in vise along flats of handwheel gland (67).
11. Place stick punch in drive-pin hole and rotate handwheel stem (58.2) CW (viewed from handwheel (58.1) end) back into the handwheel gland (67). When stem (58.2)

protrudes far enough through gland (67), relocate locking pliers to opposite end and rotate stem (58.2) until stem (58.2) fully disengages.

12. Remove O-ring (62) from handwheel gland (67).
13. Remove O-ring (63) from handwheel stem (58.2).
14. Place parts (58.2) (59) (60) (64) (67) into a suitable solvent and clean as much as possible, remove parts and allow to dry.
15. Inspect handwheel stem (58.2) with embedded ball (64) for wear on ball (64). If ball (64) is worn, or threads of stem (58.2) are damaged, replace handwheel sub-assembly (58); i.e. parts (58.1) (58.2) and (64).
16. If handwheel gland (67) shows signs of wear in female threads (i.e. loose gauging), replace handwheel gland (67) and self-tapping slotted-head screw (65). NOTE: A replacement handwheel gland (67) will require drilling a new 5/32" x 1-1/16" (4mm x 25.5mm) deep hole into the lip of the upper casing (1).
17. Install new O-ring (63) onto handwheel stem (58.2).
18. Install new O-ring (62) onto handwheel gland (67).
19. Place a thin coat of lithium grease on the handwheel stem O-ring (63) and the immediate surrounding area of the handwheel stem (58.2).
20. Engage the handwheel stem (58.2) into the gland's (67) underneath side. When the handwheel (58.1) end of the stem (58.2) protrudes through the gland's (67) upper side, place a new threadseal washer (61) over the stem's (58.2) upper end. Continue engaging stem (58.2) until the O-ring (63) is pulled into the gland (67).
21. Install washer (60) and locking lever (59) onto stem (58.2).
22. Place handwheel stem (58.2) into a soft-jawed vise. Position handwheel (58.1) onto stem (58.2) with holes for pin (66) aligned. Insert pin (66) and drive through stem (58.2) and handwheel (58.1) far side. Remove handwheel assembly (MHWO) from vise.

23. Place heavy duty wheel bearing grease as specified previously onto the stem-end ball (64). Engage the gland (67) into the upper casing (1) female opening. Align tapped opening for self-tapping slotted-head screw (65).
24. Install slotted-head screw (65) fully.

**G. Adjusting Screw Assembly and Actuator Plug Maintenance:**

1. Reference Item Number drawing at end of the IOM.
2. Determine the portion of the text of Subsection F. above that would apply to the adjusting screw assembly (ASA) counterpart of the manual handwheel operator (MHWO) assembly, and complete maintenance in a similar procedure. **NOTE:** *Adjusting screw assembly (ASA) is ONLY applied to reverse-action, ATO-FC Ranger QCT units (AA) (BA).*
3. Determine the portions of the text of Subsection F. previous that would apply to the actuator plug (67) counterpart of the manual handwheel operator (MHWO) assembly, and complete maintenance in a similar procedure. **NOTE:** *Actuator plug (67) may be applied on all Premier units (AA) (BA) and ONLY direct-action, ATC-FO Ranger QCT units (AA) (BA).*

**H. Replacement of Range Springs:**

1. Replacement of actuator assembly (AA) range springs (11) requires what is essentially a complete actuator (AA) disassembly. It is recommended that the range spring (11) replacement should include:
  - a. diaphragm (6) replacement
  - b. O-ring(s) (62) (63) replacement
  - c. threadseal (61) replacement.
2. Separate the actuator assembly (AA) from the body assembly (BA) as described in this Section, V.B.1 through V.B.9.
3. Push piston (3) downwards by:
  - a. manual handwheel operator (MHWO) being rotated CW (viewed from above handwheel (58.1)) approximately one-half of full travel.
  - b. pressurize actuator to approximately one-half of the stated benchset range; i.e. for 5-15 psig (.34-1.03 Barg) pressurize to approximately 10 psig (.69 Barg).



**WARNING**

**Do NOT stick hand or fingers into the arm housing (4) when the actuator is pressurized. ONLY USE TOOLS WITHIN ARM HOUSING (4).**

4. Place a wrench on the hex surface of the actuator's stem/pushrod (10). Rotate the push rod (10) CCW (viewed from lower L.H. rod end (9)); keep track of number of revolutions to disengage from upper R.H. rod end (8) in box below.

Number of revolutions of push rod (10) required to disengage from upper R.H. rod end (8). _____
---

5. Allow piston (3) to travel upwards by:
  - a. manual handwheel operator (MHWO) being rotated CCW (viewed from above handwheel (58.1)) fully out/up.
  - b. releasing air pressure as applied per 3.b. above; remove the air supply from actuator upper casing (1).
6. Orient actuator assembly (AA) with upper casing (1) on top side. Disassemble the actuator assembly (AA) to the point of diaphragm (6) replacement as described in this Section V.E.1 through V.E.11.
7. Place a matchmark at flange of lower casing (2) and correspondingly at piston (3). Lift off piston (3) in a vertical direction to prevent tipping range springs (11) over. Set piston (3) on work surface upside down.
8. Remove all range springs (11) and set in a row side-by-side. Inspect for any difference in the spring (11) height or verticality. Replace any abnormal spring(s) (11). Replace any springs (11) that show cracks, nicks, damaged epoxy coating, corrosion, etc. Inspect springs (11) using data in table below as the "normal":

Part Number	Benchset Range psig (Barg)	Qty. of Springs	Free Height * in (cm)	Coating Color
830-H2-5-R9069-95	5-15 (0.34-1.03)	6	5.60 (14.23)	Grey

\* Acceptable ± 1/8" (± 3 mm)

- Inspect clevis (7), upper R.H. rod end (8), clevis pin (48), washers (53) and hairpin (49) for signs of looseness and/or wear; replace any worn parts. Check bolting (26) for looseness; tighten as necessary to 15-18 ft-lbs (20-23 N-m).

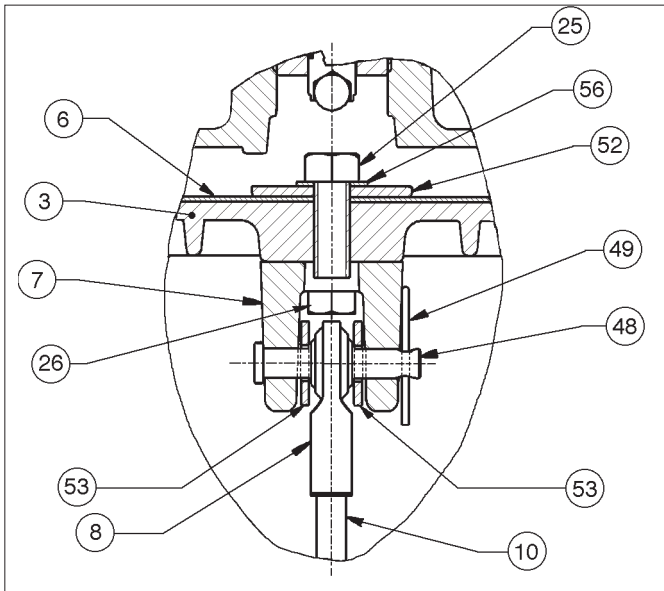

**Figure 12**  
Piston & Clevis Close-up

- Place range springs (11) back onto hubs of lower casing (2) per following table:

**NOTE:** Every spring (11) has another spring (11) 180° across/opposite.

Benchset Range		Quantity of Springs	Array
psig	(Barg)		
5-15	(0.34-1.03)	6	

- Aligning matchmarks of Article 7. above, reposition piston (3) back onto top side of range spring (11) array. Using a mirror tool and flashlight, look through the rectangular opening in the lower casing (2) from within the arm housing (4) to ensure that the piston (3) hubs are centered within the ID of the range spring (11) coil. It may be necessary to use a tool to move the upper end of the range spring (11) as necessary to be “captured” by a piston (3) hub. Each spring (11) **MUST** be captured by a hub on top and bottom ends.

- Reinstall a new diaphragm (6) and reassemble the upper casing (1) as described in this Section, V.E.12 through V.E.24.
- Using air pressure of V.E.24., pressurize the actuator upper casing (1) to the upper value of the stated benchset range plus 2 psi (0.14 Bar); i.e. for 5-15 psig (0.34-1.03 Barg) benchset range, pressurize to  $15+2=17$  psig ( $1.03+0.14=1.17$  Barg). This pressure level should cause the piston’s (3) lower skirt-edge to bottom out on the lower casing (2).
- Using only tools (i.e. no fingers within arm housing (4)) to grasp the actuator stem/push rod (10), insert push rod (10) with interconnected parts (9) (43) (43) (44) (54) into arm housing (4) and engage into dangling upper R.H. rod end (8) by rotating CW (viewed from lower L.H. rod end (9)). Count number of revolutions of push rod (10) engagement to match those recorded in Article 4., previous, at removal.
- Release all air pressure into actuator upper casing (1); remove air source from 1/4" FPT connection.
- Join the actuator assembly (AA) to the body assembly (BA) as described in this Section, V.I.

#### I. Joining of Body Assembly (BA) to Actuator Assembly (AA):

- Determine proper orientation of actuator (AA)-to-body (BA) for the following considerations:
  - failsafe action
  - installed piping orientation.

Reference Sub-sections V.C. and V.D. to see schematics of orientations available.

- Position body assembly (BA) on a flat work surface. Orient such that the actuator assembly (AA) can be oriented with the top of the actuator upper casing (1) on topside; i.e. manual handwheel operator sub-assembly (MHWO) stem (58.2) vertically oriented, if supplied.
- Using an overhead hoist, lift the actuator assembly (AA) (with position indicator apparatus (13,14,15,16,17,31,31,34), lever arm apparatus (5,5,12,40,46,50,50), end-of-shaft bearing (18), bearing flanges (19) and

- cover plate (20) removed) properly oriented and shift laterally over the protruding stem (Ranger (7), Premier (3.2)). Bring the round opening of the arm housing (4) into position against the mounting yoke (12). Raise/lower/tip/rotate the actuator assembly (AA) to align at least one bolt hole of the yoke (12) with one bolt hole in the arm housing (4). Insert one cap screw (24) from behind the yoke's (12) bolt hole and engage with the tapped opening in the arm housing (4); finger tighten cap screw (24).
4. Reposition actuator assembly (AA) as required to align the remaining bolt holes securing yoke (12) with arm housing (4). Insert the cap screws (24) and finger-tighten.
  5. (Wrench-tighten in one-half revolution increments and in an alternating cross-pattern the three cap screws (24) securing actuator assembly (AA) to body assembly (BA). Final tightening should be by torque wrench to 17-20 ft-lbs (23-27 N-m)
  - 6A. For units (AA, BA) with Model 73N-B P/P positioner:
    - a. Secure characterization cam (12) properly oriented over the two rolled spring pins (50) stuck into the inner lever arm (5).
    - b. Place the outer lever arm (5) over the two spring pins (50) with the bolt holes aligning. Press the apparatus (5,50,50,5) together.
  - 6B. For Units (AA, BA) with no positioner, Model 9540R P/P positioner or 991 or PS2 I/P:
    - a. Similar to 6A. above, except a spacer washer (12) replaces the cam (12) of a Model 73N-B P/P positioner.
  7. Position valve plug (Ranger (6)) / disc (Premier (3.1) in the proper "Full Closed" or "Full Open" position. **NOT FOLLOWING THIS ARTICLE WILL CAUSE MECHANICAL DAMAGE TO THE UNIT'S (AA, BA) LINKAGE MECHANISM!**
  8. Place properly oriented lever arm apparatus (5,50,12,50,5) over shaft's (Ranger (7), Premier (3.2)) square end and push into place while holding lower L.H. rod end (9) "swung" aside so as to not interfere. **NOTE: For units (AA, BA) with 73N-B P/P positioner, it will be necessary to "swing" the feedback linkage subassembly ((72)) out of the way as the lever arm apparatus (5,50,12,50,5) is pushed into place.** Center-align lever arm apparatus (5,50,12,50,5) transversely within the arm housing (4), directly over stop screw (35).
  - 9A. For units (AA, BA) with Model 73N-B P/P positioner: Place indicator spacer (17) over end of shaft (Ranger (7), Premier (3.2)) properly oriented for travel indicator (16) to be "located" by spring pin (51).
  - 9B. For units (AA, BA) with Model 9540R P/P positioner or 991 or PS2 I/P positioner: Reference the IOM-9540R or 991/PS2 IOM for proper instructions on reinstallation of indicator spacer (17) and drive coupling ((32)).
  10. Align the bolt holes in lever arms (5) and lower L.H. rod end (9). **NOTE: For units (AA, BA) with ATO-FC action it will be necessary to offset "stem windup" by –**
    - a. Rotating manual handwheel operator (MHWO) handwheel (58.1) approximately 1-3 revolutions CW (viewed from above handwheel) until the bolt holes of lever arms (5) and lower L.H. rod end (9) are aligned.
    - b. Pressurize actuator casing (1) only until the bolt holes of the lever arms (5) and the lower L.H. rod end (9) align.
  11. Insert shoulder bolt (40) through the round opening of the arm housing (4) and into the bolt holes of lever arms (5) and lower L.H. rod end (9).
  12. Ensure that lever arm apparatus (5,50,12,50,5) is transversely centered within the arm housing (4). Engage lock nut (46) together with shoulder bolt. Wrench-tighten to a torque of 15-20 ft-lbs (20-27 N-m).
  13. Position bearing flanges (19) with retainer ball bearing (18) over the spacer (17). Align the bearing flanges' (19) bolt holes with the arm housing (4) bolt holes.
  - 14A. Units (AA, BA) with Model 73N-B or without positioner:
    - a. Insert rolled spring pin (51) into indicator spacer (17). Pin (51) will protrude approximately 1/16" (1.5 mm).
    - b. Position travel indicator (16) onto end of shaft (Ranger (7), Premier (3.2)) impaling over protruding spring pin (51) and aligning with shaft-end tapped opening with hole in travel indicator (16). Align lock-tooth washer (55) on spacer (17) and secure

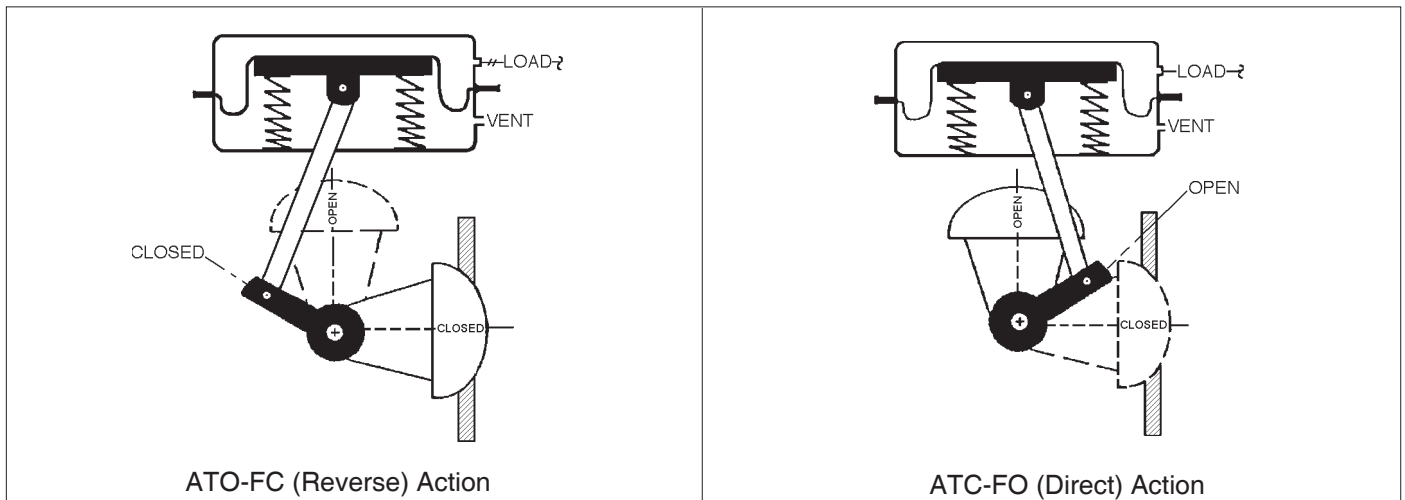

Figure 13:

- travel indicator (16) to shaft (Ranger (7), Premier (3.2)) with cap screw (32) using a 7/32" allen key wrench until firmly tight.
- Position cover plate (13) over the bearing flanges (19) aligning the cover plate (13) bolt holes with those of the bearing flanges (19). Hold cover plate (13) on outer edge with fingers. **NOTE:** Ensure that the three tapped holes in the coverplate (13) are near the 1:o'clock, 5:o'clock and 9:o'clock positions.
  - Position travel indicator dial (15) onto cover plate (13) properly oriented.
  - Position clear plastic dial lens (14) over indicator dial (15), aligning bolt holes of lens (14), dial (15) and cover plate (13).
  - Secure lens (14), dial (15), cover plate (13) and bearing flanges (19) to arm housing (4) by engaging the three socket

head cap screws (31) using a 3/16" allen key wrench and tighten firmly; do not over-tighten and crack plastic lens (14). **NOTE:** It may be necessary to rotate the actuator manual handwheel operator (58) downwards, or alternately supply a small level of air pressure (5-7 psig (0.35-0.50 Barg)) to assist in aligning bolt holes for cap screws (31). Do not tighten one single cap screw (31) until all cap screws (31) are partially thread-engaged.

- Units (AA, BA) with Models 9540R or 991 or PS2 positioners: Reference the IOM-9540R or 991 or PS2 IOMs for proper instructions on reinstallation of positioner ((PA)) assembly to shaft-end.

## SECTION VI

### VI. CALIBRATION

#### A. General:

- This section covers calibration of the actuator assembly (AA) to a Ranger QCT, Premier EZO, or Premier Unlined body assembly (BA).
- Positioner, if installed, requires reference to the specific positioner model IOM for proper calibration procedure.
- All indicated Item Numbers that are with respect to this Model 48 actuator assembly (AA) are in parenthesis but are not underscored; i.e. (20). Item Numbers that relate to the body assemblies (BA) are in parenthesis and are underscored; i.e. (7). Item Numbers that relate to the positioners ((PA)) are in a double set of

parenthesis and are underscored; i.e. ((3)).

- This Section assumes that the actuator assembly (AA) and body assembly (BA) have been interconnected together as recorded in Section V.
- This Section assumes that the calibration is performed with the valve unit removed from its normal pipeline location, and is in a repair shop located on a suitable work bench. Actuator stem/push rod subassembly (8, 9, 10, 43, 43, 43, 44, 54) should be oriented vertically.
- Premier EZO (lined) body assembly (BA) MUST be properly clamped between two ANSI 150# RF weld neck flanges. NOTE: Flanges MUST be of weld neck type! Clamping of liner (Premier (10)) will prevent false movement of liner (Premier (10)) within body (1).

7. In this Section reference will be made to three phrases –
  - a. “lower value of benchset range”,
  - b. “higher” value of benchset range”,
  - c. benchset range.

The meaning of these phrases is summarized in the following table.

Benchset Range *	Lower Value of Benchset Range	Higher Value of Benchset Range
5-15 psig (.34-1.03 Barg)	5 psig (0.34 Barg)	15 psig (1.03 Barg)

\* Identified on nameplate (21) as “Bench” or “Input Range”.

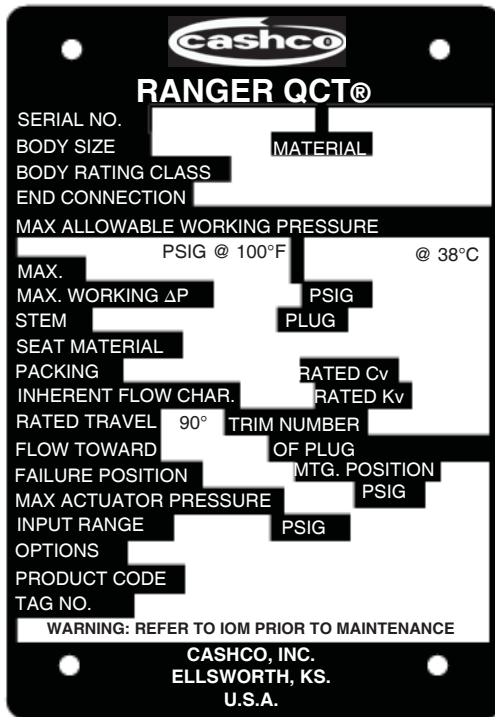

**WARNING**

**Do not pressurize actuator assembly (AA) beyond the “MAX ACTUATOR PRESSURE” level/value indicated on the unit’s nameplate (21). Failure to heed may cause catastrophic failure of upper casing (1) leading to flying parts.**

## B. Actuator Stem/Push Rod Adjustment:

1. Actuator stem/push rod linkage (8, 9, 10, 43, 43, 43, 44, 54) when properly adjusted will-
  - a. Provide the proper benchset range.
  - b. Provide 90° rotation.
  - c. Provide proper valve stem (Ranger (Z), Premier (3.2)) “windup”.
2. Ensure that manual handwheel operator (MHWO) has handwheel (58.1) backed fully out by rotating CCW (viewed from above handwheel (58.1)).
3. Remove cover plate (20) by removing four screws (36).
4. Remove travel indicator dial (15), dial lens (14), coverplate (13), bearing flanges (19) and bearing (18) by removing three cap screws (31) using a 3/16" allen key wrench.
5. Units with ATO-FC (Reverse) Action:
  - a. Disconnect the lower L.H. rod end (9) from engagement with the lever arms (5) by removing shoulder bolt (40) and lock nut (46). It will be necessary to remove stem (Ranger (Z), Premier (3.2)) “windup” as described in Section V.B.4.
  - b. Swing the lever arms (5) down against the travel stop screw (35); this “opens” valve plug (6)/disc (3.1).
  - c. Loosen lower upstop jam nut (43) from securing upstop washer (54); back nut (43) to the root of its threads on push rod (10).
  - d. The upper R.H. rod end (8), lower L.H. rod end (9), and push rod (10) act together as a turnbuckle; the upper end is standard right-hand threaded while the lower end is left-hand threaded. To ensure maximum and equal engagement of rod ends (8,9) to the push rod (10), it is recommended that the linkage (8,9,10) be fully engaged and then readjusted as a safety precaution.

**CAUTION**

**Unequal engagement adjustment of rod ends (8,9) and push rod (10) can cause failure of a rod end (8,9)-to-push rod (10) connection.**

- a. If this occurs during bench maintenance, the parts (8,9,10) could snap apart and cause personal injury.
- b. If this occurs during installed operation,

**control function would be lost.**

- e. Loosen lower L.H. rod end (9) jam nut (44) by rotating CW (viewed from above); this nut (44) is “left-handed”. Back nut (44) to the root of its threads on push rod (10).
- f. Using a suitable tool to prevent lower L.H. rod end (9) from rotating, rotate push rod (10) CCW (viewed from above) until upper end of push rod (10) is fully engaged with upper R.H. rod end (8). **NOTE: If lower L.H. rod end (9) reaches full engagement with lower push rod (10) end first, remove tool securing against rotation, and allow lower L.H. rod end (9) to rotate with push rod (10).** Once upper end of push rod (10) is fully engaged with upper R.H. rod end (8), rotate lower L.H. rod end (9) CW (viewed from above) until it is fully engaged.
- g. Provide a temporary air supply with an inline adjustable airset to the actuator upper casing (1) connection.
- h. Reference the nameplate (21) attached to the cover plate (20) that is fastened to the arm housing (4). Determine the bench setting from the nameplate (21).
- i. Pressurize the actuator (AA) to the lower value of the benchset range pressure indicated on the nameplate (21).
- j. While holding lower L.H. rod end (9) out of way, lift lever arms (5) up as far as possible (this will close plug (Ranger (5))/disc (Premier (3.1))).
- k. Rotate lower L.H. rod end (9) as required to orient the holes of the rod end (9) and the lever arms (5) in the same plane. Swing lower L.H. rod end (9) between the lever arms (5).
- l. Rotate the push rod (10) CW (viewed from above) lowering the lower L.H. rod end (9) until it’s hole is centered with the lever arm (5) holes. Center lever arms (5) within arm housing’s (4) transverse axis; i.e. center over travel stop screw (35).
- m. Reinstall the shoulder bolt (40) through the lever arm (5) and lower L.H. rod end (9) holes. Finger-tighten lock nut (46) onto shoulder bolt (40). Using a 1/4" allen key wrench to secure the head of shoulder bolt (40), torque wrench-tighten nut (46) to 15-20 ft-lbs (20-27 N-m).
- n. Tighten lower L.H. jam nut (44) down until locked against lower L.H. rod end (9); nut (44) is “left-handed”.
- o. Add approximately 6 psig (0.4 Barg) to the actuator’s (AA) lower value of benchset range. This will extend the actuator stem/push rod sub-assembly (8, 9, 10, 43, 43, 44, 54) downwards to allow loosening double jam nuts (43) on top side of uptravel stop washer (54).
- p. Release air pressure down to the lower value of benchset range.
- q. Rotate lower jam nut (43) to raise uptravel stop washers (54) until the gap clearance between the lower casing (2) and the top side of the washer (54) is 1/8"±1/16" (3mm±1.5mm).
- r. Repressurize actuator (AA) to level as indicated in Article 5.o. above. Tighten the lower of the two upper jam nuts (43) until it is tight, and secures the uptravel stop washer (54). Tighten the upper of the two upper jam nuts (43) down to secure the double jam nut (43) locking effect. Retighten lower jam nut (43) on underneath side of washer (54).
- s. Release all air pressure from actuator upper casing (1). Repressurize slowly to confirm that as the pressure reaches the lower value of the benchset range (see Article 5.i. previous), the actuator stem/push rod sub-assembly (8, 9, 10, 43, 43, 43, 44, 54) begins to move. If movement is prematurely occurring (i.e. movement at less than the lower benchset range value), the length of the actuator stem sub-assembly (8, 9, 10, 43, 43, 43, 44, 54) must be shortened. Repeat procedure from Article 5.a. through to this Article. If movement is late (i.e. movement at more than the lower benchset range value), the length of the actuator stem sub-assembly (8,9,10,43,43,43,44,54) must be lengthened (i.e. increased). Repeat procedure from Article 5.a. through to this Article. It is recommended that adjustment of actuator stem sub-assembly (8, 9, 10, 43, 43, 43, 44, 54) be made in one revolution of push rod (10) increments. Repeat as necessary.
- t. Slowly increase air pressure in upper casing (1) until reaching the higher value of the benchset range; i.e. pressurize only until plug (Ranger (5))/disc (Premier (3.1)) is in the full open position.
- u. Release all air pressure in actuator upper casing (1). Repeat Article 5.t above and this article, cycling valve unit (AA, BA) closed-open-closed-open-closed several times.
- v. With valve plug (Ranger (5)) / disc (Premier (3.1)) in “full closed” position, reinstall bearing (18), bearing flanges (19), coverplate (13), dial lens (14) and

dial (15) with three cap screws (31).  
**NOTE:** Position dial (15) such that travel indicator (16) shows "0°" travel before fully tightening screws (31).

- w. Completion to this point completes the benchset range adjustment. Proceed to Subsection VI.C. to adjust 90° travel stop.
- 6. Units with ATC-FO (Direct) Action:
  - a. Disconnect the lower L.H. rod end (9) from engagement with the lever arms (5) by removing shoulder bolt (40) and lock nut (46).
  - b. Swing the lever arms (5) down and as close as possible to the travel stop screw (35); this "closes" valve plug (6) / disc (3.1). Ensure that the "closed" position is reached by observing actual plug (6) / disc (3.1) position.
  - c. Loosen lower upstop jam nut (43) from securing upstop washer (54); back nut (43) to the root of its threads on push rod (10).
  - d. The upper R.H. rod end (8), lower L.H. rod end (9), and push rod (10) act together as a turnbuckle; the upper end is standard right-hand threaded while the lower end is left-hand threaded. To ensure maximum and equal engagement of rod ends (8,9) to the push rod (10), it is recommended that the linkage (8,9,10) be fully engaged and then readjusted as a safety precaution.

L.H. rod end (9) to rotate with push rod (10). Once upper end of push rod (10) is fully engaged with upper R.H. rod end (8), rotate lower L.H. rod end (9) CW (viewed from above) until it is fully engaged.

- g. Provide a temporary air supply with an inline adjustable airset to the actuator upper casing (1) connection.
- h. Reference the nameplate (21) attached to the cover plate (20) that is fastened to the arm housing (4). Determine the bench setting from the nameplate (21).
- i. Rotate lower L.H. rod end (9) until the rod end (9) and the lever arm's (5) holes are in the same plane.
- j. Loosen jam nut (45) and rotate downtravel stop screw (35) out by rotating CCW (viewed from below screw's (35) head) until just barely engaged in arm housing (4).
- k. Pressurize actuator (AA) to the higher value of the benchset range pressure indicated on the nameplate (21), while "guiding" the lower L.H. rod end (9) hub to its proper position between the lever arms (5).
- l. Pressurize actuator (AA) to a level as indicated by "C" pressure in table that follows according to the formula: "A" + "B" = "C".

Benchset Range	Higher Value of Benchset Range - "A"	Adder Value - "B"	Loading Pressure - "C"
_____ psig	_____ psig	2 psig	_____ psig
_____ Barg	_____ Barg	.14 Barg	_____ Barg

 **CAUTION**

**Unequal engagement adjustment of rod ends (8,9) and push rod (10) can cause failure of a rod end (8,9)-to-push rod (10) connection.**

- a. **If this occurs during bench maintenance, the parts (8,9,10) could snap apart and cause personal injury.**
- b. **If this occurs during installed operation, control function would be lost.**

- e. Loosen lower L.H. rod end (9) jam nut (44) by rotating CW (viewed from above); this nut (44) is "left-handed". Back nut (44) to the root of its threads on push rod (10).
- f. Using a suitable tool to prevent lower L.H. rod end (9) from rotating, rotate push rod (10) CCW (viewed from above) until upper end of push rod (10) is fully engaged with upper R.H. rod end (8). **NOTE:** If lower L.H. rod end (9) reaches full engagement with lower push rod (10) end first, remove tool securing against rotation, and allow lower

- m. Adjust the push rod (10) by rotating CW (viewed from above) until the holes of the lever arms (5) and the lower L.H. rod end (9) are centered and the valve is in the "closed" position.
- n. Reinstall the shoulder bolt (40) through the lever arm (5) and lower L.H. rod end (9) holes. Finger-tighten lock nut (46) onto shoulder bolt (40). Using a 1/4" allen key wrench to secure the head of shoulder bolt (40), torque wrench-tighten nut (46) to 15-20 ft-lbs (20-27 N-m).
- o. Loosen double jam nuts (43,43) on top side of uptravel stop washer (54).
- p. With valve in "closed" position, reinstall bearing (18), bearing flanges (19), coverplate (13), dial lens (14) and dial (15) with three cap screws (31). **NOTE:** Position dial (15) such that travel indicator

- (16) shows “0°” travel (no “bright orange” showing from indicator (16)) before fully tightening screws (31).
- q. Fully release air pressure in actuator (AA). Observe position of valve on travel indicator (16). Travel should be short of “full open”; i.e. 90° rotation.
    1. Travel short of 90°. Adjust the push rod (10) by rotating CCW (viewed from above) until the travel reaches 90° as shown by travel indicator (16).
    2. Travel beyond 90°. Adjust the push rod (10) by rotating CW (viewed from above) until the travel is reduced to 90° as shown by the travel indicator (16).
  - r. Rotate lower jam nut (43) to raise uptravel stop washers (54) until the gap clearance between the lower casing (2) and the top side of the washer (54) is  $1/8" \pm 1/16"$  ( $3\text{mm} \pm 1.5\text{mm}$ ).
  - s. Repressurize actuator (AA) to upper value of benchset range. Tighten the lower of the two upper jam nuts (43) until it is tight, and secure the uptravel stop washer (54). Tighten the upper of the two upper jam nuts (43) down to secure the double jam nut (43) locking effect. Retighten lower jam nut (43) on underneath side of washer (54).
  - t. Tighten lower L.H. jam nut (44) down until locked against lower L.H. rod end (9); nut (44) is “left-handed”.
  - u. For Premier EZO and Premier Unlined ONLY. Reference VI.C.2. for procedure to adjust downtravel stop screw (35).
  - v. Release all air pressure in actuator upper casing (1). Repeat loading-unloading to cycle the valve unit (AA, BA). Repeat adjustments as necessary.
  - w. Completion to this point completes the benchset range adjustment. Proceed to the next subsection (VI.C.) to adjust 90° travel stop, if necessary.

- b. Rotate downtravel stop screw (35) CCW (viewed from below screw (35)) until 90° rotation is reached on the travel indicator (16).
- c. Retighten jam nut (45).
2. Travel beyond 90°. Hub of lower L.H. rod end (9) may or may not be touching on downtravel stop screw’s (35) upper end.
  - a. Loosen jam nut (45) about four revolutions.
  - b. Very slowly release air pressure into actuator (AA) until travel indicator (16) is showing at 90°.
  - c. Rotate downtravel stop screw (35) CW (viewed from below screw (35)) until the screw’s (35) upper edge touches the hub of lower L.H. rod end (9).
  - d. Retighten jam nut (45).

**2. Units with ATC-FO (Direct) Action:**

- a. Loosen jam nut (45).
- b. Rotate downtravel stop screw (35) CW (viewed from below screw (35)).
- c. Pressurize actuator (AA) slowly until the travel indicator (16) indicates that travel is at 0°; the valve should be in the “fully closed” position.
- d. Adjust gap between downtravel stop screw (35) and hub of lower L.H. rod end (9) as indicated in table that follows.
- e. Retighten jam nut (45).

Product Model	Gap Between L.H. Rod End (9) and Downtravel Stop Screw (35)
Ranger QCT	$1/8" \pm 1/16"$ ( $3.0\text{ mm} \pm 1.5\text{ mm}$ )
Premier EZO	$1/16" \pm 1/16"$ ( $1.5\text{ mm} \pm 1.5\text{ mm}$ )
Premier Unlined	No gap; i.e. touching

**C. 90° Rotation Adjustment:**

**1. Units with ATO-FC (Reverse) Action:**

- a. Pressurize actuator (AA) to the higher value of benchset range. This pressure should cause 90° rotation as shown by travel indicator (16).
  1. Travel short of 90°. Hub of lower L.H. rod end (9) may be touching on downtravel stop screw’s (35) upper end.
    - a. Loosen jam nut (45).

## SECTION VII

### VII. TROUBLE SHOOTING GUIDE

Reference the IOM of the valve body this actuator is unitized with for additional information on Trouble Shooting.

#### 1. Air leakage.

Possible Causes	Remedies
A. Leakage at diaphragm-to-upper casing flange.	A1. Overpressure. Check source of air supply and determine if pressure is greater than indicated in Table 1; reset airset pressure as required. A2. Tighten casing flange bolting (27, 28, 41 & 42)
B. Leakage at handwheel gland-to-upper case.	B. Faulty O-ring (62); replace O-ring.
C. Leakage at manual handwheel threads.	C. Faulty seal (61); replace thread seal.
D. Leakage around stem on side where yoke bolts to arm housing.	D1. Failure of diaphragm (6); replace diaphragm. D2. Faulty seal (56); replace seal.

## SECTION VIII

### VIII. ORDERING INFORMATION

#### NEW REPLACEMENT UNIT vs PARTS "KIT" FOR FIELD REPAIR

To obtain a quotation or place an order, please retrieve the Serial Number and Product Code that was stamped on the metal name plate and attached to the unit. This information can also be found on the Bill of Material ("BOM"), a parts list that was provided when unit was originally shipped. (Serial Number typically 6 digits). Product Code typical format as follows: (last digit is alpha character that reflects revision level for the product).

□□□□ - □□□□ 7 - □□□□□□□□□□

#### NEW REPLACEMENT UNIT:

Contact your local Cashco, Inc., Sales Representative with the Serial Number and Product code. With this information they can provide a quotation for a new unit including a complete description, price and availability.

#### PARTS "KIT" for FIELD REPAIR:

Contact your local Cashco, Inc., Sales Representative with the Serial Number and Product code. Identify the parts and the quantity required to repair the unit from the "BOM" sheet that was provided when unit was originally shipped.

CAUTION

**Do not attempt to alter the original construction of any unit without assistance and approval from the factory. All purposed changes will require a new name plate with appropriate ratings and new product code to accommodate the recommended part(s) changes.**

**NOTE:** *Those part numbers that have a quantity indicated under "Spare Parts" in column "A" reflect minimum parts required for inspection and rebuild, - "Soft Goods Kit". Those in column "B" include minimum trim replacement parts needed plus those "Soft Goods" parts from column "A".*

If the "BOM" is not available, refer to the cross-sectional drawings included in this manual for part identification and selection.

A Local Sales Representative will provide quotation for appropriate Kit Number, Price and Availability.

The contents of this publication are presented for informational purposes only, and while every effort has been made to ensure their accuracy, they are not to be construed as warranties or guarantees, express or implied, regarding the products or services described herein or their use or applicability. We reserve the right to modify or improve the designs or specifications of such product at any time without notice.  
Cashco, Inc. does not assume responsibility for the selection, use or maintenance of any product. Responsibility for proper selection, use and maintenance of any Cashco, Inc. product remains solely with the purchaser.

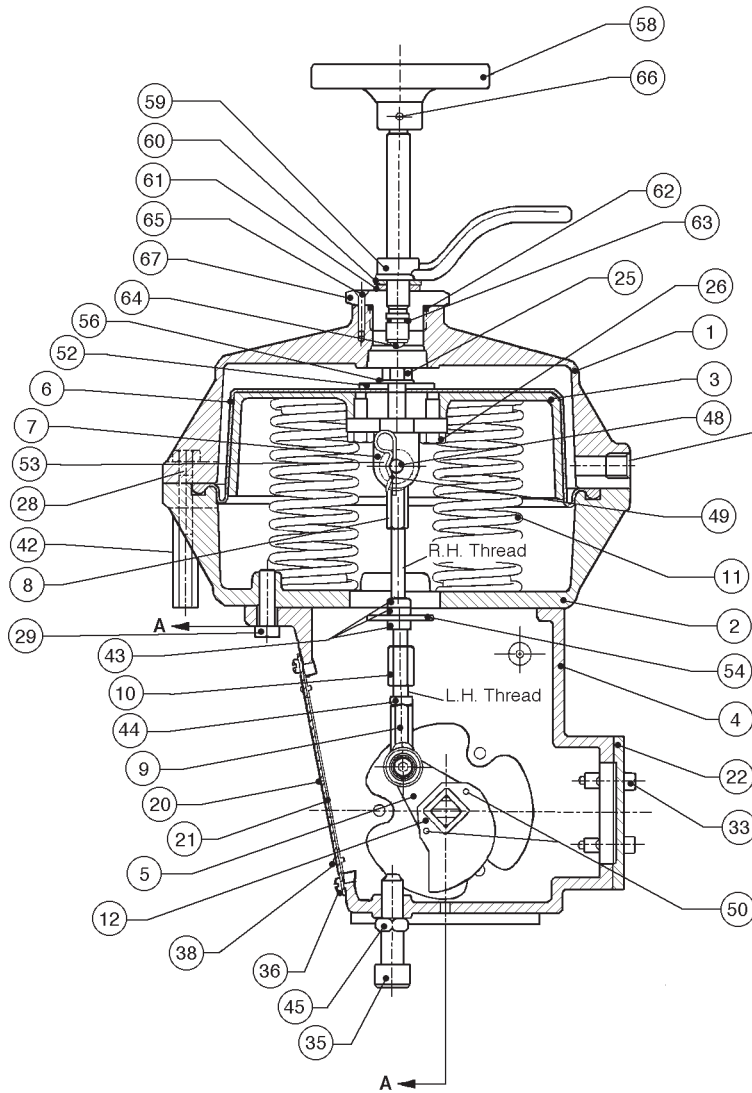

**BASIC 48 ACTUATOR**  
Shown Air to Open

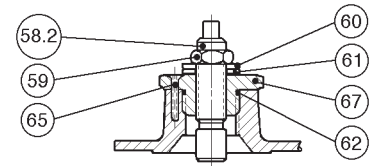

**ADJUSTING SCREW ASSEMBLY**  
Not available on Air to Close-Fail Open Rangers

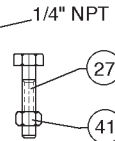

**ACTUATOR PLUG**  
Available on Premier Butterfly Valves ONLY

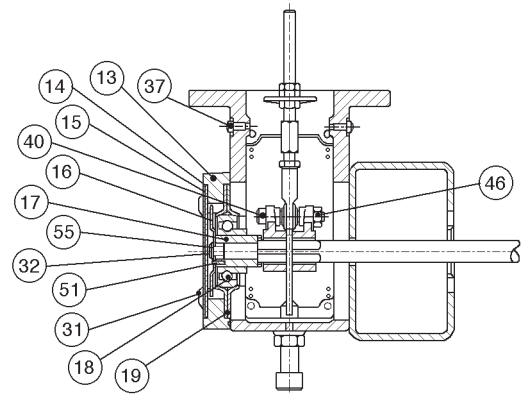

**SECTION "A-A"**

ITEM NO.	DESCRIPTION	ITEM NO.	DESCRIPTION	ITEM NO.	DESCRIPTION
1.	Upper Case	22.	Housing Cover	49.	Hairpin
2.	Lower Case	25.	Pivot Screw	50.	Spring Pin
3.	Piston	26.	Hex. Head Cap Screw	51.	Spring Pin
4.	Arm Housing	27.	Hex. Head Cap Screw	52.	Diaphragm Washer
5.	Arm	28.	Hex. Head Cap Screw	53.	Washer
6.	Diaphragm	29.	Hex. Head Cap Screw	54.	Stop Washer
7.	Clevis	31.	Button Head Cap Screw	55.	Internal Lock Tooth Washer
8.	Rod End (R.H.)	32.	Button Head cap Screw	56.	Seal
9.	Rod End (L.H.)	33.	Socket Head Cap Screw	58.	Handwheel Subassembly or Adjusting Screw
10.	Push Rod	35.	Socket Head Stop Screw	59.	Locking Lever or Nut
11.	Spring	36.	Fillister Head Machine Screw	60.	Washer
12.	Cam	37.	Fillister Head Machine Screw	61.	Thread Seal
13.	Cover Plate	38.	Drive Screw	62.	O-Ring (Gland to Upper Case)
14.	Dial Lens	40.	Bolt Shoulder	63.	O-Ring (Handwheel to Gland)
15.	Travel Indicator Dial	41.	Nut	64.	Ball
16.	Travel Indicator	42.	Extension Nut	65.	Self-Tapping Screw
17.	Indicator Spacer	43.	Jam Nut	66.	Pin (Spring)
18.	Ball Bearing	44.	Jan Nut (L.H.)	67.	Handwheel Gland or Actuator Plug
19.	Bearing Flange	45.	Jam Nut		
20.	Cover Plate	46.	Lock Nut		
21.	Name Plate	48.	Clevis Pin		

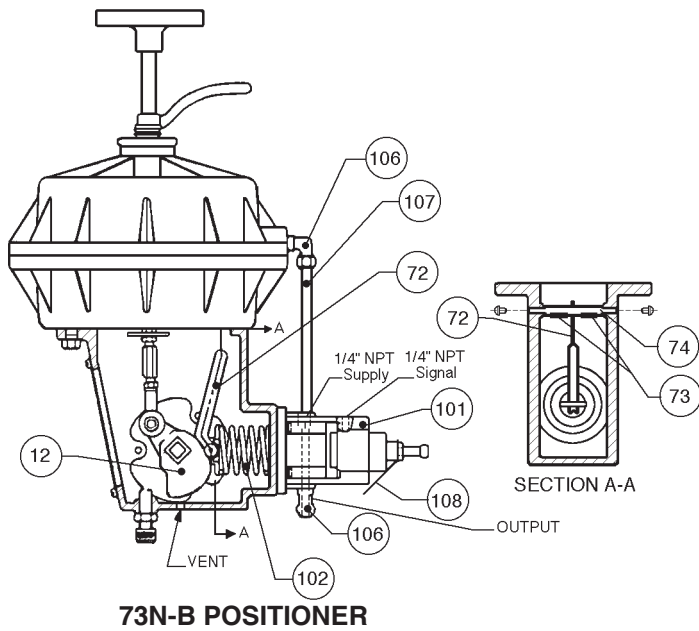

**73N-B POSITIONER**

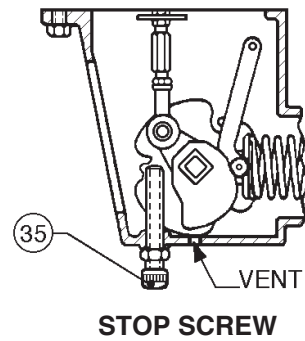

**STOP SCREW**

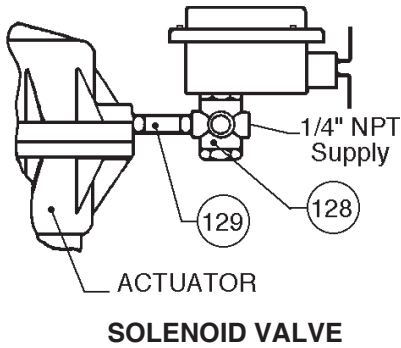

**SOLENOID VALVE**

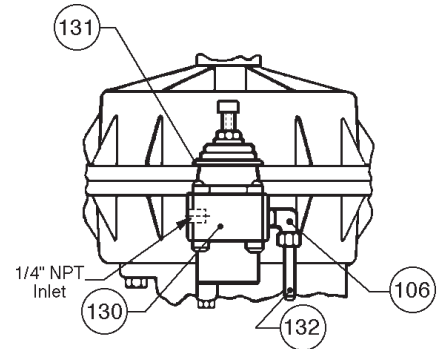

**AIR SUPPLY REGULATOR**

**73N-B POSITIONER**

ITEM NO.	DESCRIPTION
72	Feedback Linkage Subassembly
73	Feedback Linkage Spacer
74	Feedback Linkage Pivot Shaft
101	Positioner
102	Range Spring
106	Tube Fittings (Elbow)
107	Output Tube
108	Name Plate

**SOLENOID VALVE**

ITEM NO.	DESCRIPTION
128	Solenoid Valve
129	Nipple

**AIR SUPPLY REGULATOR**

ITEM NO.	DESCRIPTION
130	Air Supply Regulator
131	Mounting Bracket
132	Supply Tube

**GUAGES (Not Shown)**

ITEM NO.	DESCRIPTION
135	Signal Gauge
137	Output Gauge
138	Branch Tee
139	Reducing Bushing