

Stafsjö
SINCE 1666

Standard accessories



Standard accessories

Content

Product features	3
Solenoid valves	4
Filter regulators	5
Magnetic limit switches	6
Inductive limit switches	7
Mechanical limit switches	8
Ebro SBU switch box	9
Junction box	9
Air accumulator fail-safe solution	10
Fully automated purge systems	11
Purge port pipe systems only	12
Flow control solutions	13
Valve capacity Kv/Cv on MV with V-port and on MV standard	14
Gland box reinforcements	16
Deflection cone	17
MV reverse flow supports	18
Mechanical lockouts	19
Performance accessories to the slurry valves SLV, SLF, SLH and SLX	20
Stem extension solutions	21

Product features

1 Direct mounting of solenoid valves

The namur interface on cylinder top end cap enable a compact installation of solenoid valves without any extra pipe works.

2 Magnetic detection

The T-slot on the cylinder barrel enable mounting of magnetic limit switches to detect open/close against the magnetic piston ring. This is standard up to SC200. Detection on request for larger cylinders.

3 Stainless steel gate guards

For safety Stafsjö equips all automated valves with stainless steel gate guards. Manually operated on request.

4 Modular concept

On Stafsjö's valves it easy to go from manually operated to automated on/off or to automated control with a positioner. Stafsjö supply conversion sets on request. The aluminum encapsulated stainless steel tie rods enable a steady operation independent of valve position.

5 Gate indication

As an option the valve can be supplied with gate indicator pin to visually indicate opened and closed position.

6 Lockouts

Both manually and automated valves can be supplied with lockouts in opened/closed position.

7 Prepared for limit switches

Every automated valve is supplied with extra holes in the beams for an easy assembly of limit switches either at customer plant or prior delivery from Stafsjö. Assembly kits can be supplied on request.

8 An easy maintenance

Stafsjö's knife gates can be maintained and re-build brick by brick and easily re-configured to new challenging operations over and over again. The retainer ring concept enable a quick replacement of resilient wearing parts.

9 Tested and approved

To ensure quality and expected performance, Stafsjö pressure test each and every knife gate valve prior delivery.

Made to last

Experienced and engineered design, precise and controlled manufacturing and testing, an easy maintenance and a modular concept are all important success factors to achieve low life cycle cost. This all is what you can expect when investing in a Stafsjö knife gate valve. Our solutions are made to last.

If valve add-ons and automation accessories described in this documents does not fulfill your demands, please feel free to get in touch with us directly or with any of our sales partners around the world. We collaborate with all well known automation brands.

Namur solenoid valves

Stafsjö's standard solenoid valves are supplied by Hafner. They have a housing of anodized aluminum and its interface corresponds to the Namur standard, which gives a compact design of the actuator/solenoid valve unit. It is a 5/2 way valve available in 1/4" and 1/2". The solenoid valve is supplied with spring return and as standard Stafsjö install it on the pneumatic actuator to close the knife gate valve at any electrical signal interruption. Further to this the solenoid valve is supplied as standard with manual override to turn, coils in either 24 V DC, 110 V AC or 230 V AC, silencers with speed control and a connector with LED indicator. The solenoid valve correspond to IP class 65. ATEX and other IP versions on request.



General info	
Function:	5/2 valve monostable
Interface	Namur 1 interface according to VDI/VDE 3845 on 1/4". Namur 2 interface on 1/2"
Material specifications:	Anodized aluminium body, other internal parts and sealings in stainless steel, brass, POM and NBR.
Manual override:	Standard on all versions
Indication type	Red LED
Media:	Cleaned and lubricated or cleaned and unlubricated compressed air quality level 5 acc. ISO 8573-1
Fluid temperature:	-10 °C to +50 °C on AC-coils and -10 °C to +60 °C on DC-coils. Others on request.
Air-flow:	1/4" 1250 l/min - 1/2" 3000 l/min
Operating pressure	2-10 bar
Voltage:	24 V DC ± 10%, 110 V AC ± 10%, 230 V AC ± 10%. Specify on order.
Power consumption:	3 W / 5 VA
Cable connection diameter	6-8 mm
Protection:	IP65
ATEX approvals:	Only on request

Filter regulators

Stafsjö's standard filter regulators are supplied by Parker type P31 (1/4") and P32 (1/2") with round gauge included. Other brands and types on request. The P31 and P32 are mini filter regulators that provides accurate pressure regulation and high moisture removal efficiency in a compact package. The filter regulator is supplied with bracket and nipples for assembly at customer site to make sure it is installed in correct position to drain.

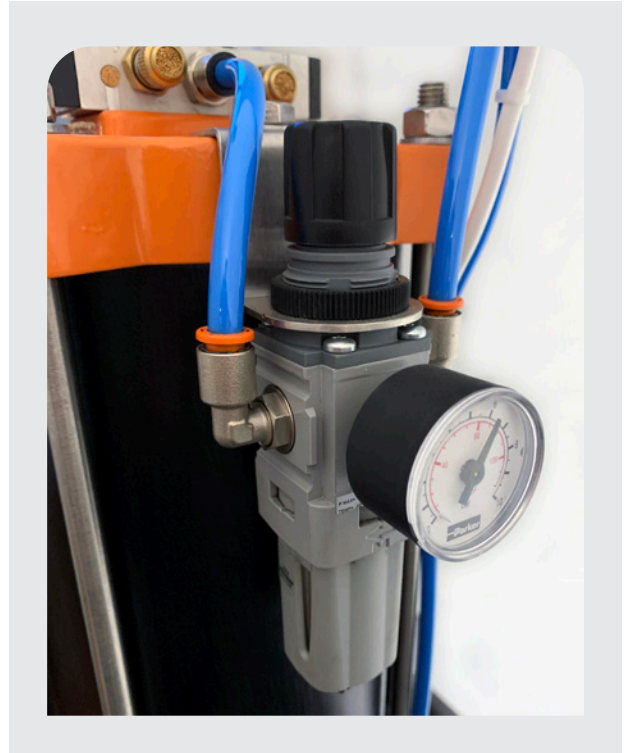

General info	
Model	Parker P31 (1/4") and Parker P32 (1/2")
Filter element	Polyethylene 5 micron
Regulator type	Relieving
Port size	1/4" or 1/2"
Port type	BSPP. NPT on request.
Inlet pressure rating	10 bar
Operatig temperature	-10 °C to +52 °C
Body material	Aluminum
Bowl type	Polycarbonate with Nylon guards
Seal material	Nitrile
Drain type	Manual drain. Puls on request.
Gauge port size	1/8"
Gauge type	Round
Adjustment range with round gauge	8 bar

Magnetic limit switches

Stafsjö's standard magnetic limit switches type MR0902 from IFM offers a simple installation and secure operation. It is as standard supplied with 2 m three wire connection PUR cable type EVC141 from IFM. The switch can be installed in the "T" groove on the SC cylinder range when they also are equipped with magnetic piston ring to indicate open and closed position of the valve.



Magnetic limit switch with reed contact	
Type	MR0902
Suitable for cylinder	SC100 SC125 SC160 SC200 SC250 on request SC320 on request
Electrical design:	AC/DC PNP
Operating voltage:	5-50 V AC/5-60 V DC
Output function:	normally open
Current rating:	350 AC/500 DC mA
Mounting:	non-flush mountable
Switching frequency:	1000 Hz
Connection:	M8 connector
Housing materials:	housing: PA (polyamide) fixing element: stainless steel/brass
Ambient temperature:	-25 to +70°C
Protection:	IP 65/IP 67
Output status indication:	LED yellow

Three wire connection cable	
Type	EVC141
Suitable for switch:	MR0902 with M8 connector
Design	Straight
Operating voltage:	50 V AC / 60 V DC
Electrical design:	AC/DC
Connection:	PUR cable / 2 m; 3 x 0.25 mm ²
Material body:	housing: TPU orange sealing: Viton
Material nut:	Brass nickel-plated
Ambient temperature:	-25 to +90°C, cULus: max. 80 °C
Protection:	IP 65/IP 67/IP 68/IP 69K

Inductive limit switches

Stafsjö's automated valves are as standard supplied with holes in the beams to enable an easy assembly of limit switches. The standard inductive limit switches are supplied by IFM and they are available in two versions; one 3-wire DC PNP and one 2-wire AC/DC. Both switches have a plastic PBT housing with thread M18 x 1 and 2 m PVC cable. The maximal sensing ranges for both switches are 8 mm.



Two wire version	
Type	ifm IG0006
Operating voltage:	20 - 250 V AC/DC
Electrical design:	AC/DC
Output function:	normally open
Current rating (continuous):	350 AC (50 °C) / 250 AC (80 °C) / 100 DC mA
Current rating	î: 2.2 A (20 ms / 0.5 Hz) mA
Length:	80 mm
Mounting:	non-flush mountable
Sensing range:	8 mm
Switching frequency:	25 AC / 50 DC Hz
Connection:	PVC cable / 2 m; 2 x 0.5 mm ²
Housing materials:	PBT
Ambient temperature:	-25 to +80 °C
Protection:	IP67
Output status indication:	LED yellow

Three wire version	
Type	ifm IG5401
Operating voltage:	10 - 36 V DC
Electrical design:	DC PNP
Output function:	normally open
Current rating:	250 mA
Length:	80 mm
Mounting:	non-flush mountable
Sensing range:	8 mm
Switching frequency:	300 Hz
Connection:	PVC cable / 2 m; 3 x 0.5 mm ²
Housing materials:	PBT
Ambient temperature:	-25 to +80 °C
Protection:	IP67
Output status indication:	LED yellow

Mechanical limit switches

Stafsjö's automated valves are as standard supplied with holes in the beams to enable an easy assembly of limit switches. The standard mechanical limit switch are supplied by Omron and has a double insulated plastic and metallic housing according to IP65, a stainless steel arm and a stainless steel bracket for an easy assembly on the valve beams. The switch has 1NO and 1NC contact.



Technical info	
Type	Omron D4V
Operating speed	5 mm to 0.5 m/s
Operating frequency	30 operations / minute
Insulation resistance	100 M Ω min. (500 V DC)
Contact resistance	Max. 25 M Ω min. At (initial value)
Dielectric Strength	Between terminals with same polarity; 1,000 V AC, 50/60 Hz for 1 minute Between current carrying metal parts and ground; 1,500 VAC, 50/60 Hz for 1 minute
Rated insulation voltage, U _i	250 V
Thermal current, I _{the}	5 A (EN 60947-5-1)
Rating	AC: 12-250 V AC at 5 A, resistive load DC: 12-125 V DC at 0,4 A, resistive load 5A, 250 V AC 0,4 A, 125 V DC
Short circuit protective device	10 A fuse, gG or gI (IEC 269)
Conditional short circuit current	100 A (EN 60947-5-1)
Operating environment pollution degree	3 (IEC 947-5-1)
Protection against electric shock	Class: I
Mechanical life expectancy	Min. 10 000 000 operations
Electrical life expectancy	Min. 300 000 operations 250 V AC, 5 A with resistance load.
Ambient operating temperature	-20 °C to +60 °C (with no icing)
Ambient operating humidity	Max. 90%
Protection	IP65
Approvals	
TÜV	EN 60947-5-1
UL	UL 508
CCC	GB 14048.5

Smart valve monitoring with Ebro SBU switch box

This smart switch box serves to support plant engineers and operators with important information on each and every valve. Thanks to its conventional bluetooth interface and “EBRO Connect” app you gain access to data which is stored throughout its entire life cycle. It can be also be used as a junction box for direct connection of a solenoid valve and two limit switches. The box has a solid aluminum case which is assembled on a stainless steel bracket onto the pneumatic cylinder. ATEX option on request.

Features

- Electronic (digital) nameplate
- Parameterizable collective fault
- Position monitoring (position and time)
- Max./Min. temperatures
- Counting of cycles, failures, power loss and operating hours

Technical info

Type	Ebro SBU Advanced
Temperature range	-20 °C to +70 °C
Body	Aluminum (powder coated)
Contact terminal:	Spring type
Interface	Conventional, Bluetooth
Power supply	24 V DC \pm 10%
Power consumption	max. 200mA
Output signals	Digital outputs 24 V DC max 2 W: Closed position Open position Collective Fault
Solenoid valve	Max 1 pcs. 24 V DC, max 5W
Magnetic limit switches	Max 2 pcs. 24 V DC 2- or 3-wire (PNP)
Inductive limit switches	Max 2 pcs. 24 V DC 2- or 3-wire (PNP)
Protection class:	IP65



Circuit diagram

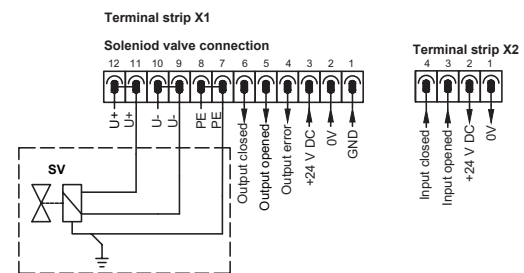

Junction box

The junction box is made of ABS plastic RAL 7035 with IP65. Ambient temperature is max 74 °C (DIN 53461 method A). The junction box is supplied with three cable glands on one side PG11 and one on the other side PG13,5. It has 10 terminal blocks and one terminal block for earthing as standard. Other configurations are available on request. The box is assembled onto the valve with a stainless steel bracket and all accessories are wired into the box prior delivery.

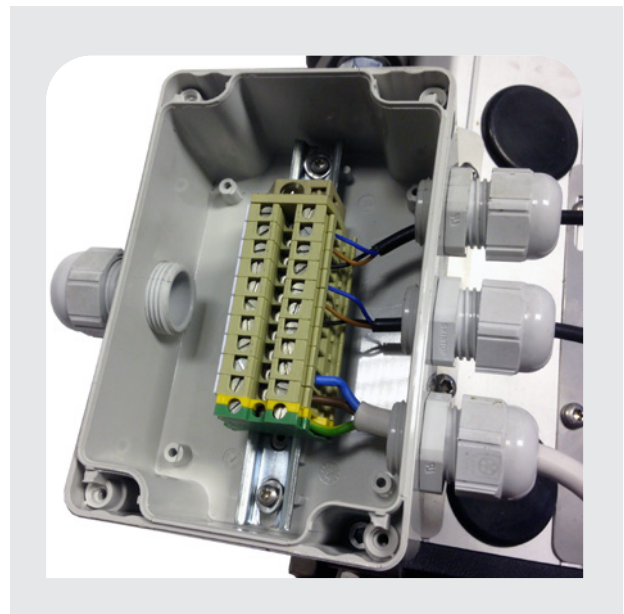

Air accumulator fail-safe solution

This solution can be used to ensure the valve open or close in event of loss of air or power. It is an excellent option when single-acting pneumatic cylinders becomes either to large, heavy or expensive.

Scope of supply

Components V1-V6, pressure release valve (max 8000 l/min), auto drain, gauge and tank. All components are sized for 5 bar air supply pressure, specified valve and actuator size. Position V1 to V6 are all assembled on a bracket onto the pneumatic cylinder and the rest on the air tank. As standard the electronics comes in 24 V DC versions.

ATEX options

Only the electrical components are available in ATEX versions. Tank and related accessories must therefore be mounted outside the zone.



Circuit diagram

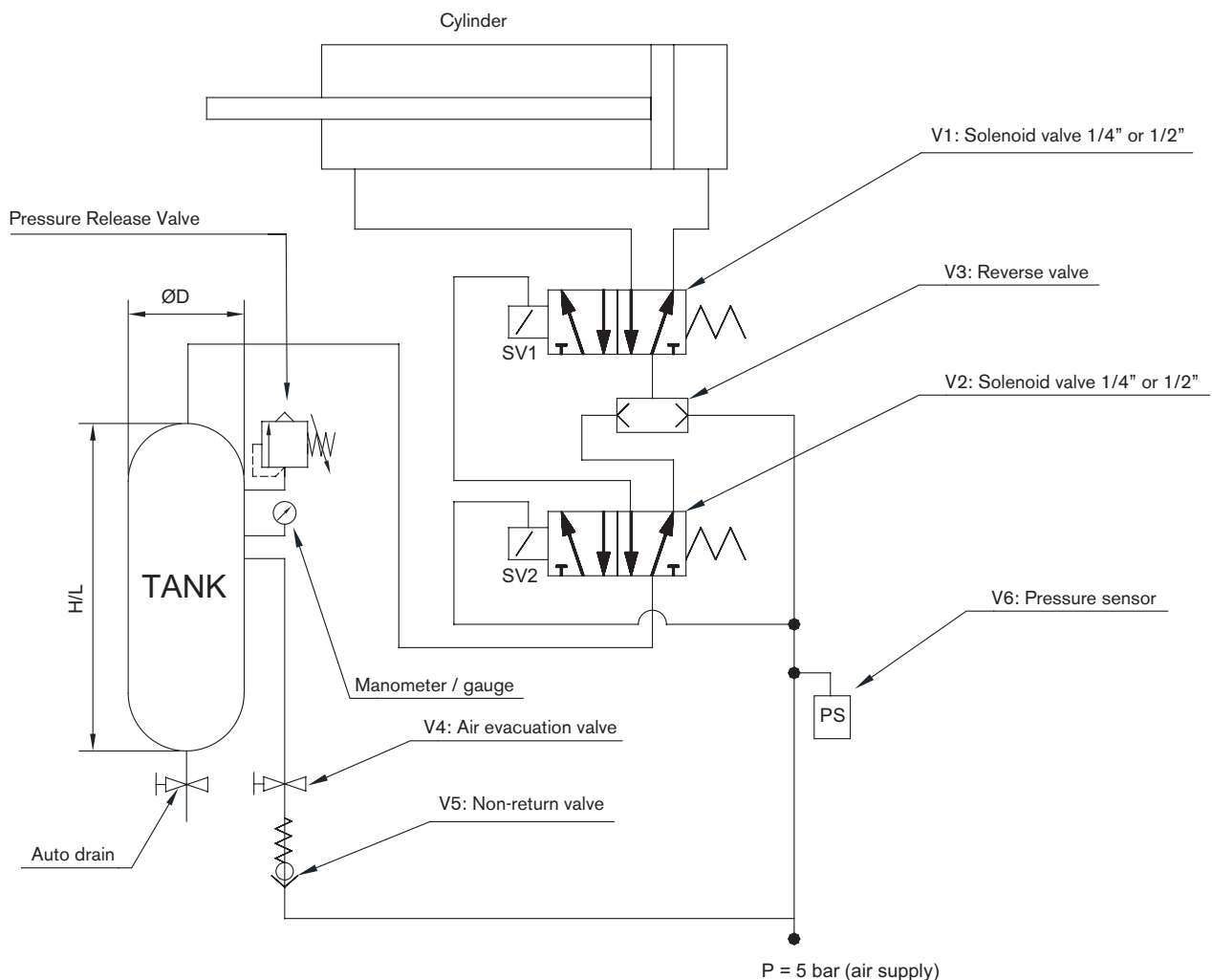

Available tank dimensions

Volume (dm ³)	ØD	H/L
100 (horizontal)	370	1016
270 (vertical)	500	1648
500 (vertical)	600	2050
900 (vertical)	1100	2140

Wiring

- V1: Connected for normal use open/close
- V2: Connected to V6 switching at set pressure drop between air supply and tank.
- V2 will automatically switch at < 3 bar in case of electrical failure.

Fully automated purge systems

In some applications the media can build up or scale inside the valve and prevent the gate from smoothly operate to its full open or closed position. It can be related to rarely operated high consistency pulp stock isolations, slurry systems where the media cannot be discharged externally during cycling or dry powder handling where the valves' internals has to be cleared during each cycling.

Several of Stafsjö's products have purge ports as standard to utilize if needed while others can be supplied with it on request. Stafsjö can also supply a Fully Automated Purge System to clear out internal build-ups that can be a problem for the valve and its operation to valves from DN 50 (2") up to DN 1600 (64"). The system is built ready and will be assembled on the valves prior delivery, only to be connected to flush source at site and 100 - 240 V AC power supply.

We have two versions available (Standard or Performance) to run on either air or water. The control unit has enclosure IP 65 and can operate in temperature intervals from -20 up to +40 °C.

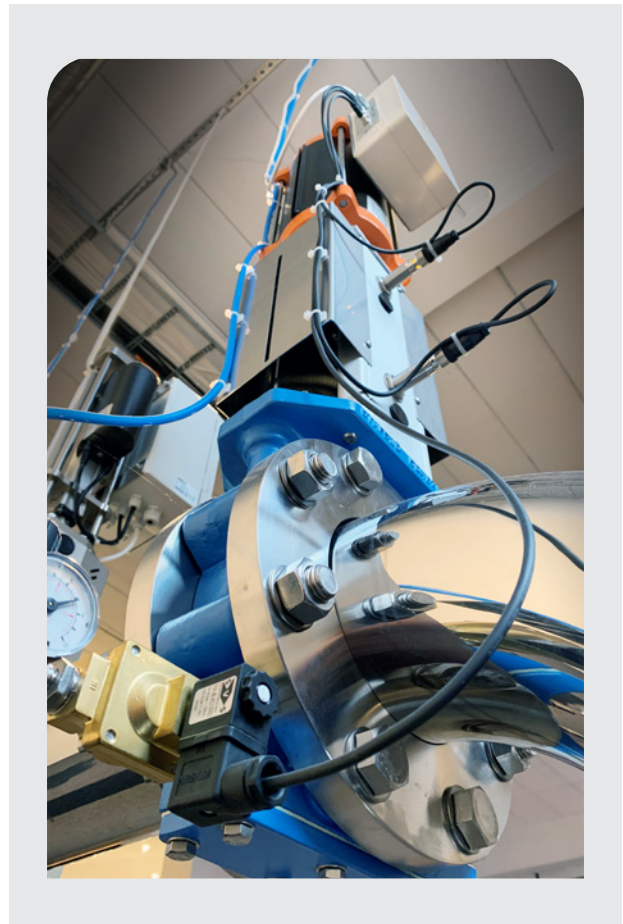

Circuit diagram standard version

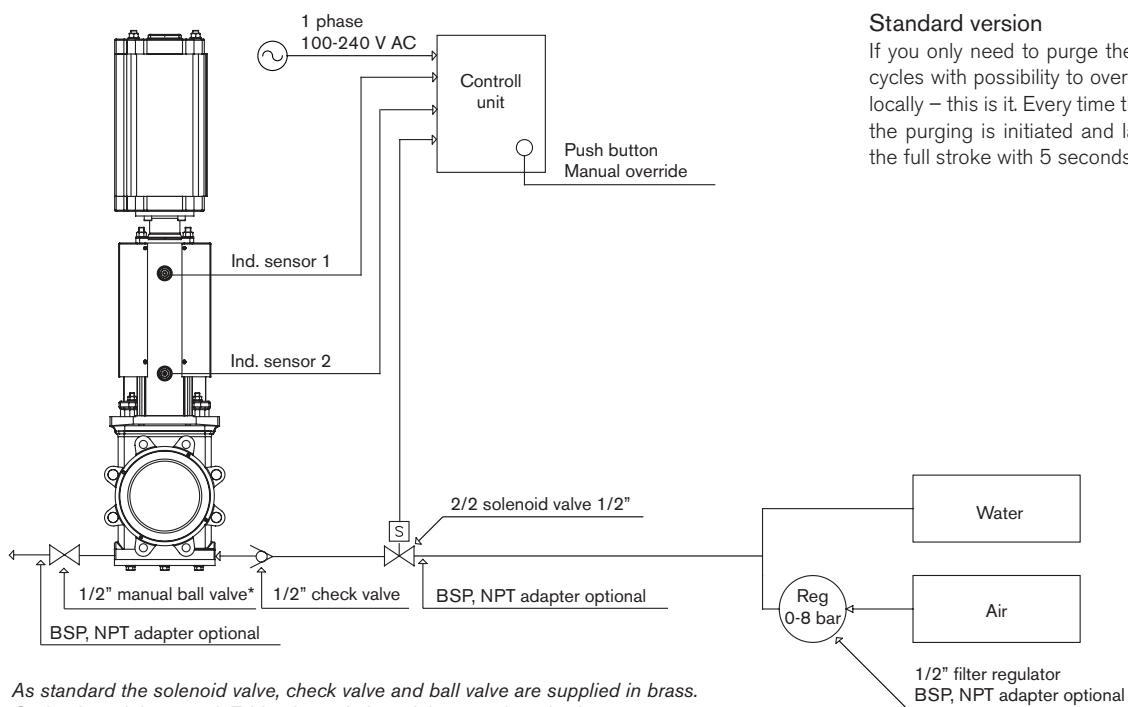

Standard version

If you only need to purge the valve when it cycles with possibility to overrun it manually locally – this is it. Every time the valve cycles the purging is initiated and last throughout the full stroke with 5 seconds overrun time.

As standard the solenoid valve, check valve and ball valve are supplied in brass. Option in stainless steel. Tubing is made in stainless steel or plastic.

* For systems only require purging into the valve with no discharge, the manual ball valve will be excluded from the supply.

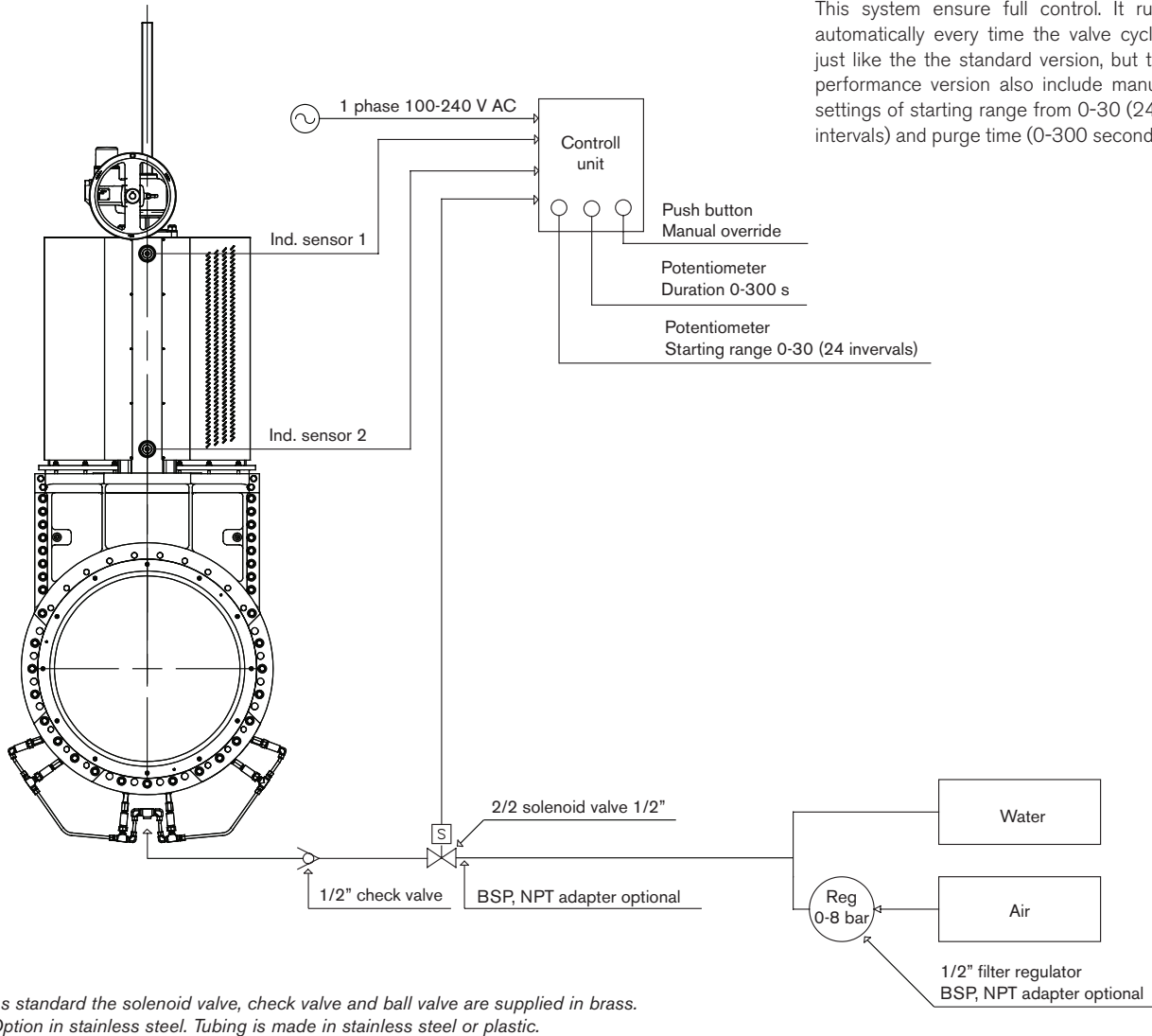

Purge port pipe system only

A light version of the fully automated purge system can be supplied on request to the MV valve. This solution require additional automation at customer level. It include purge ports connected with stainless steel pipe works.

1. Inlet of purge media.
Position depend on valve size and customer preferences.
2. Check valves to prevent back flow.
Standard from DN 300/12".
3. Purge port nipples.
Number of connected ports depend on valves size.
4. Standard valve purge ports.
Can be connected on request.

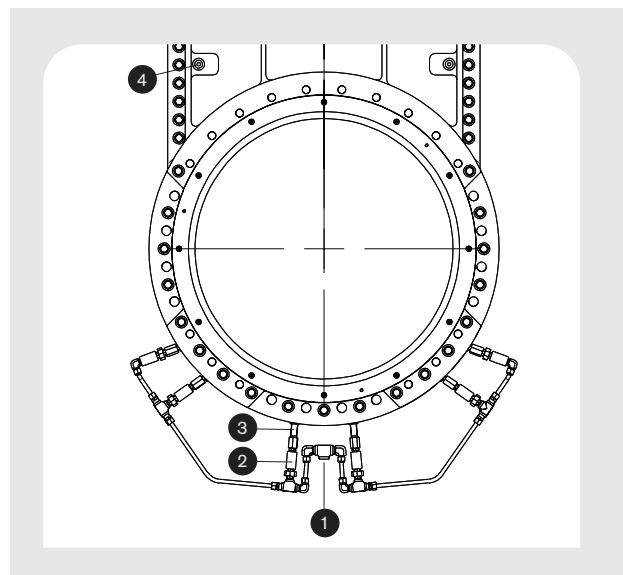

Flow control solutions

Normally the full bore knife gate valve is used for isolating on/off services. It can be related to applications with dry or viscous media such as pulp stock or fluids with solids such as slurry. In some applications one still want to benefit from the knife gates compact face-to-face and full bore design, but there is a need throttle the flow or to monitor the cycling time and flow rate carefully. To these kind of applications Stafsjö can supply a compact positioner solution easy to install on new valves and also already installed ones.

Positioner solution for modulating service

- Double-acting pneumatic cylinder including a magnetic piston.
- Magnetic positioning sensor type MPA made by Sick.
- Positioner type Festo CMSX, Neles ND7000 or ND9000 PU piped to the pneumatic cylinder. Stainless steel pipe works on request. Festo pilot valve booster type VUWS are included and compactly installed on pneumatic cylinders larger than 200 mm bore size.

Single-acting, ATEX versions and other positioner brands can be supplied on request.

Festo positioner type CMSX (Stafsjö standard)

The CMSX is a digital electropneumatic positioner that enable a simple and efficient control.

Features

- Double-acting version
- Fail-safe or fail-in-place safety function
- No internal air consumption in steady state
- 4-wire technology
- Operating pressure 3-8 bar
- Operating voltage 24 V DC
- Setpoint input 4-20 mA, 0-20 mA or 0-10 V
- Position feedback 4-20 mA
- 1 digital input
- 2 digital outputs
- 1 digital alarm output for feedback of the device status
- Standard nominal flow rate 130 l/min at 6 bar
- Temperature range -5 to +60 °C
- Compact IP65 plastic housing

Festo pilot valve booster type VUWS

The booster increase the flow rate to ensure faster valve cycle speed.

Features

- Inlet pressure: 5 bar
- Signal and output pressure: 2,5-10 bar
- Nominal flow: 2000 NI/min at 6 bar
- Material: Aluminum



Type code Stafsjö standard Festo positioner CMSX

Double-acting cylinders type code
CMSX-P-SE-C-U-F1-D-130-A

Product version

P Mainly polymer

Design

SE Positioner, external detection sensor (Sick MPA)

Display type

C LCD, backlit

Setpoint value

U Configurable 4-20 mA, 0-20 mA or 0-10 V

Position feedback

F1 4-20 mA

Function

D Double-acting

Flow

130 130 l/min

Safety function¹⁾

A Opening or closing in the event of system failure

C *Maintain position in the event of system failure (Optional)*

¹⁾ Failure of the operating voltage supply or the setpoint specification

Valve capacity K_V/C_V

The valve capacity values (K_V) below are empirically produced. All tests are made on the Stafsjö knife gate valve type MV. The tests have been made with a V-port and a standard retainer ring, called round bore.

$$C_V = 1,167 \times K_V$$

Designation and units:

K_V Valve capacity $\frac{m^3 / h}{\sqrt{bar}}$

C_V Valve capacity gpm/ \sqrt{psi}

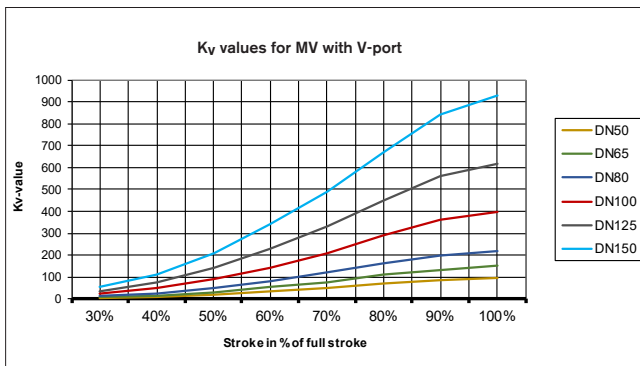

The V-port can be used on MV or HG knife gate valve for fixed throttling of flow or modulating services. It replace the normal round retainer ring without changing the face-to-face dimension.

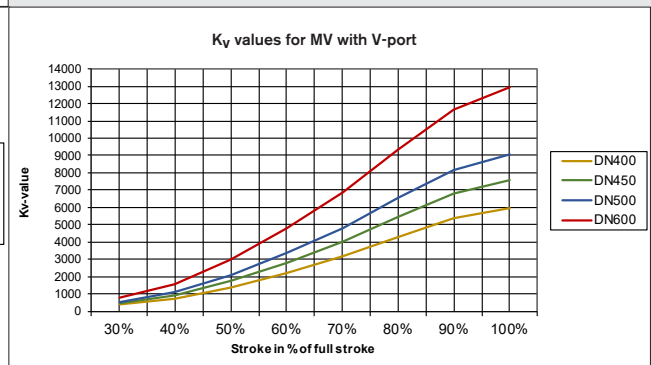
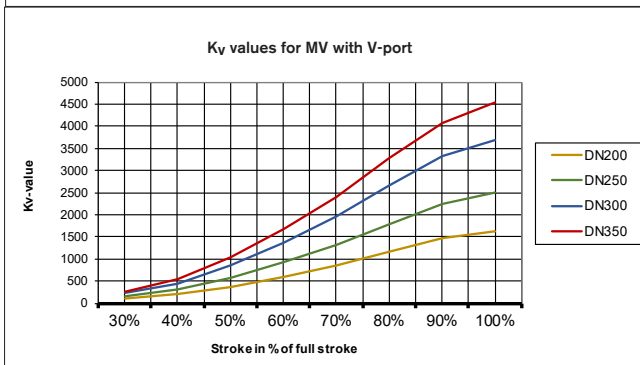

K_V values for MV with V-port

Stroke in % of full stroke	DN	50	65	80	100	125	150	200	250	300	350	400	450	500	600
30%		5	10	15	25	35	55	95	150	220	270	360	450	550	770
40%		10	15	25	50	75	110	200	300	440	540	710	910	1090	1550
50%		20	30	50	90	140	210	370	570	850	1040	1370	1730	2090	2970
60%		35	55	80	140	230	340	600	920	1370	1680	2200	2790	3360	4780
70%		50	75	120	210	330	490	860	1320	1960	2400	3150	4000	4820	6840
80%		70	110	160	290	450	670	1170	1790	2660	3270	4280	5430	6550	9290
90%		85	130	200	360	560	840	1460	2240	3320	4080	5350	6790	8180	11620
100%		95	150	220	400	620	930	1620	2490	3690	4540	5940	7540	9090	12910

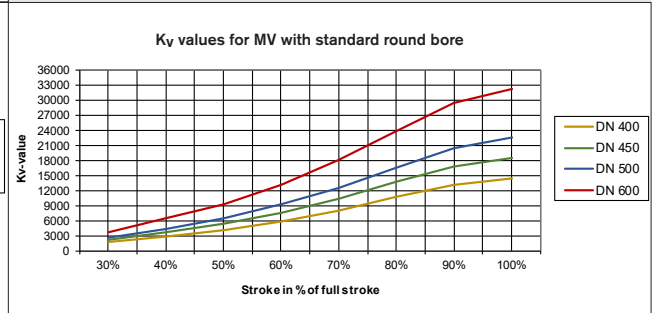
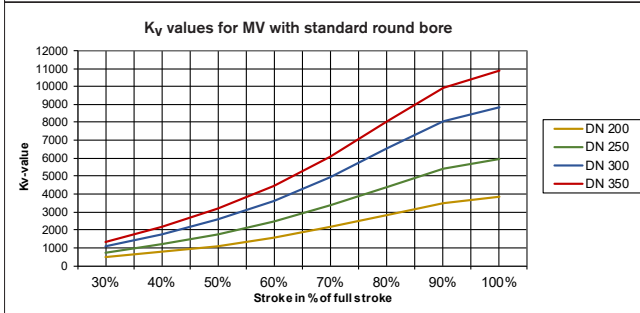
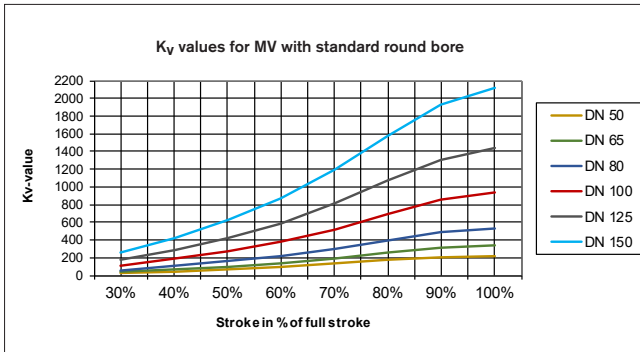

K_v values for MV with standard round bore

Stroke in % of full stroke	DN 50	DN 65	DN 80	DN 100	DN 125	DN 150	DN 200	DN 250	DN 300	DN 350	DN 400	DN 450	DN 500	DN 600
30%	25	40	60	110	170	254	460	720	1060	1310	1740	2230	2710	3870
40%	45	70	110	190	290	420	770	1190	1770	2180	2900	3710	4510	6450
50%	65	100	160	270	420	620	1110	1730	2570	3160	4210	5380	6540	9360
60%	90	140	220	380	590	870	1570	2450	3630	4470	5950	7600	9250	13230
70%	130	190	300	520	810	1190	2150	3340	4960	6100	8120	10390	12630	18070
80%	170	260	400	690	1070	1570	2830	4420	6560	8060	10730	13730	16690	23880
90%	200	310	490	850	1310	1930	3490	5430	8060	9910	13200	16880	20520	29370
100%	220	340	530	940	1440	2120	3830	5970	8860	10890	14500	18550	22550	32270

Gland box reinforcements

An extra scraper (1) can be installed in the gland box to further reinforce the packings scraping function. They are available in PTFE, UHMW-PE or brass.

To the most demanding services Stafsjö can supply valves with one extra braided box to additionally reinforce the external sealing. We call it DOUBLE GLAND (2). It is often used on high cycling applications such as junk traps and in difficult biomass applications. The double gland consist of two glands where the lower one has an integrated chamber with purge ports and two braided boxes. The first box takes care of the main sealing function while the second one secure that no media reaches surrounding environment. Flushing through the purge ports in between the glands keeps the gate clean and remove any media that might have passed through the first box.

Double gland availability with pipe threads on purge ports

DN	MV	HG	RKO	JTV
80	R 1/4"	R 1/4"	-	-
100	R 3/8"	R 3/8"	R 3/8"	-
150	R 1/2"	R 1/2"	R 1/2"	-
200	R 1/2"	R 1/2"	R 1/2"	-
250	R 1/2"	R 1/2"	R 1/2"	R 1/2"
300	R 1/2"	R 1/2"	R 1/2"	-
350	R 1/2"	R 1/2"	R 1/2"	-
400	R 1/2"	R 1/2"	R 1/2"	-

Pos.	Detail	Material
8	Gland 2	Stainless steel EN 1.4408
8a	Stud bolt	Stainless steel A2
8b	Washer	Stainless steel A2
8c	Nut	Stainless steel A2
9	Box packing	TwinPack as standard
9a	Scraper	UHMW-PE as standard
54	Gland no. 1 and chamber	Stainless steel EN 1.4408

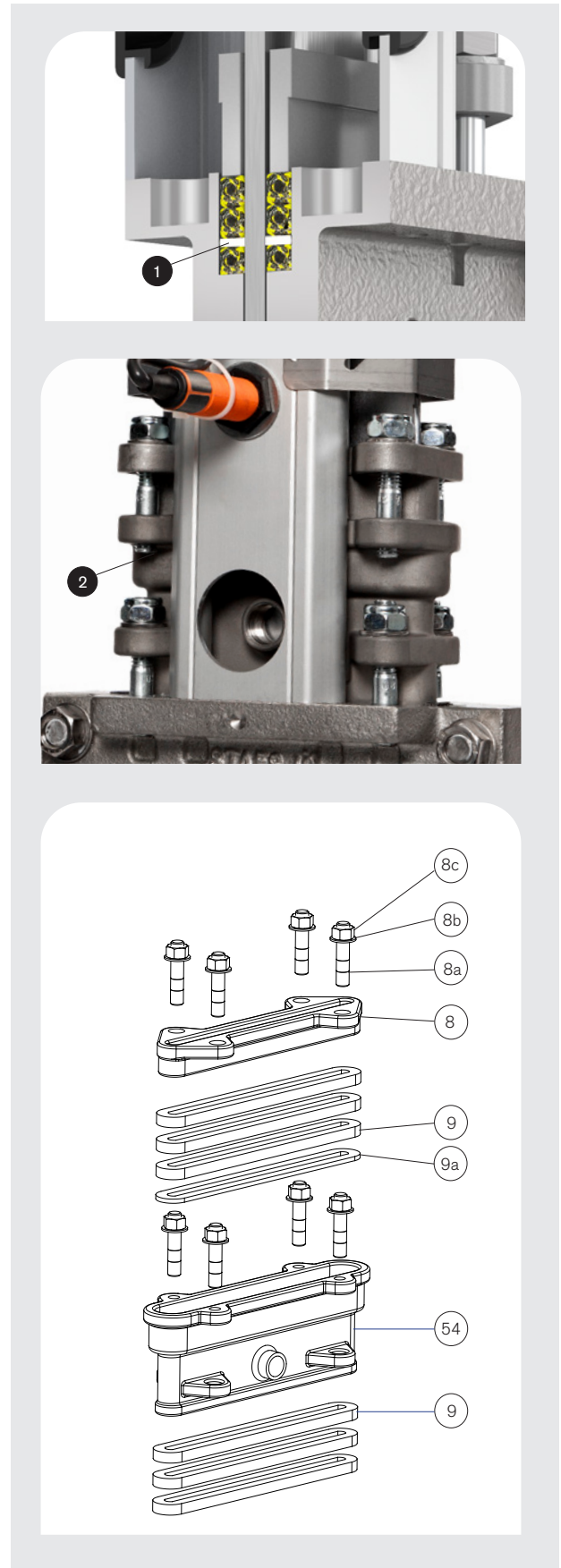

Deflection cone

This deflection cone (1) can be used on the MV valve to direct the flow into the centre of the bore and protect internal valve parts from abrasion. It shall be installed on opposite side to the seat side. As standard it is available in stainless steel EN 1.4408 with DIXO4000 gasket. Other materials on request.

Main dimensions

DN	Ac	Cc	Bc
50	39	91	48
65	51	107	48
80	63	124	57
100	86	153	57
125	110	179	62
150	135	204	66
200	179	267	67
250	230	319	76
300	280	374	85
350	325	425	85
400	373	479	97
450	423	534	97
500	467	579	122

*Main dimensions are only for information. Contact Stafsjö for certified drawings.
All specifications are subject to change without notice.*

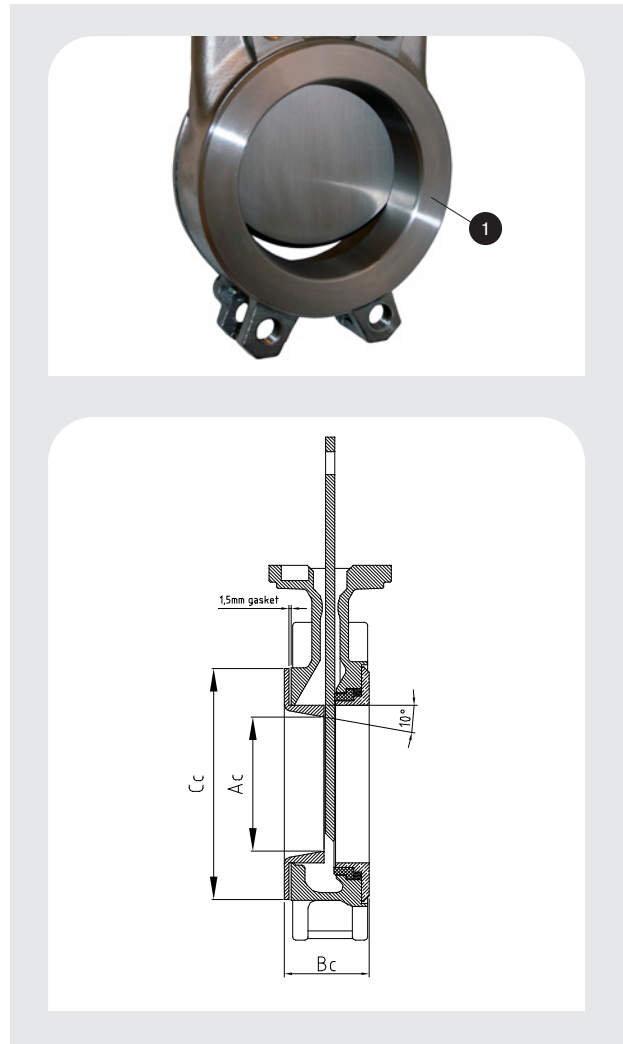

MV reverse flow supports

In some applications there are occasions with back pressure drops that can damage uni-directional valves if they are not designed for this. It can also be related to vertical flow applications where it is preferred to install uni-directional valves with the seat side on the inlet side to reduce seat wear and to improve flow characteristics.

Stafsjö can on request deliver larger uni-directional MV valves with extra gate supports to withstand a reverse flow pressure. The execution is considered “product tight” and normally but not limited to 1 bar reverse pressure, PTFE seat and stainless steel valve body.

Add-on features

1. Upper chest PTFE/POM supports
2. Purge ports to utilize if media dry and block
3. Extra cams welded or casted into the bore

Note

Full stainless steel MV up to DN 250 and nodular iron version up to DN 450 have extra cams and supports as standard to withstand and seal tight to a reverse flow up to 3 bar when supplied with resilient seat.



Mechanical lockouts

Stafsjö's lockout solutions ensure the valves cannot be operated once locked. Pneumatic or hydraulic operated valves can be locked in opened or closed position with a solid lockout fork (2) in stainless steel while hand wheel operated valves can be locked with a padlock through the hand wheel and the locking device on the yoke or simply with a lockout wire and padlock.



Performance accessories to the slurry range SLV, SLF, SLH and SLX

Stem and piston rod protection

To protect the stem on hand wheel or electric operated valves and the piston rod on pneumatic operated valves from dirt and dust, Stafsjö can supply a bellow (SP) to protect these parts throughout the entire stroke.



Bottom cover

The bottom cover is supplied in coated nodular iron together with a gasket (Dixo 4000), screws and washers in stainless steel (A2). The bottom screw plugs on SLH and SLX are supplied in zinc coated steel. When installed the valve body purge ports must be utilized to avoid build of solids that can damage the valve.

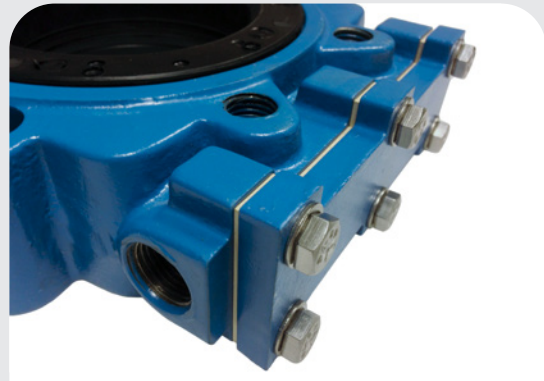

Lockout pins

For security reason the slurry valves are always supplied with extra holes in the beams and the gate to enable lockout in opened or closed position with a locking pin. The locking pin is supplied in stainless steel EN 1.4301.



Load distribution rings

When the pipes and flanges are rubber lined or when they do not match up to inlet diameter of the valve or cover the metal frame around the seats, it is recommended to assemble and install the valve with load distribution rings. The load distribution rings ensure the seats get support and maintain correct position in the bore when the valve cycles. The load distribution rings are supplied as standard in stainless steel EN 1.4301.

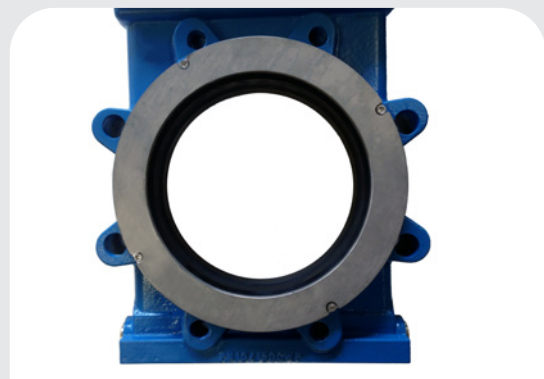

Stem extension solutions

Stafsjö is able to supply robust, steady and proper dimensioned stem extension kits for the valves in two versions; one for shorter extensions up to 1,5 m and one for longer than 1,5 m. The valves can also be prepared for T-key maneuvering according to standard DIN 3223 C.

Stem extension short < 1,5 m

This stem extension is very easy to install and consist of few parts. Two adapters are included; one for the valve stem (M) and one for the hand wheel (G). Both adapters are supplied in stainless steel.

The stem extension must be supported with minimum one support close to the actuator. Stem extension supports are the same as for stem extension long, see picture on next page.

Details in stem extension short

Valve stem adapter (M)



Holes to connect the adapters to the stem. Screws and nuts in stainless steel (A4) are included in the stem extension kit.

Hand wheel adapter (G)



Stem extension long > 1,5 m

This stem extension kit offers great flexibility and it can be combined with all of Stafsjö's valves and actuators. The stem extension has a linear movement and all valves and actuators are therefore supplied with rising stems. The knife gate valves are also supplied with pillars (J) in stainless steel for improved corrosion resistance.

The stem extension must be supported with minimum one support close to the actuator. The distance between the stem extension supports shall not exceed 1700 mm. Floor column (K) for the actuator can be supplied on request for any actuator and it is available in stainless steel EN 1.4404.



Stem extension short on WB14



Stem extension long on WB14

Parts in stem extension long

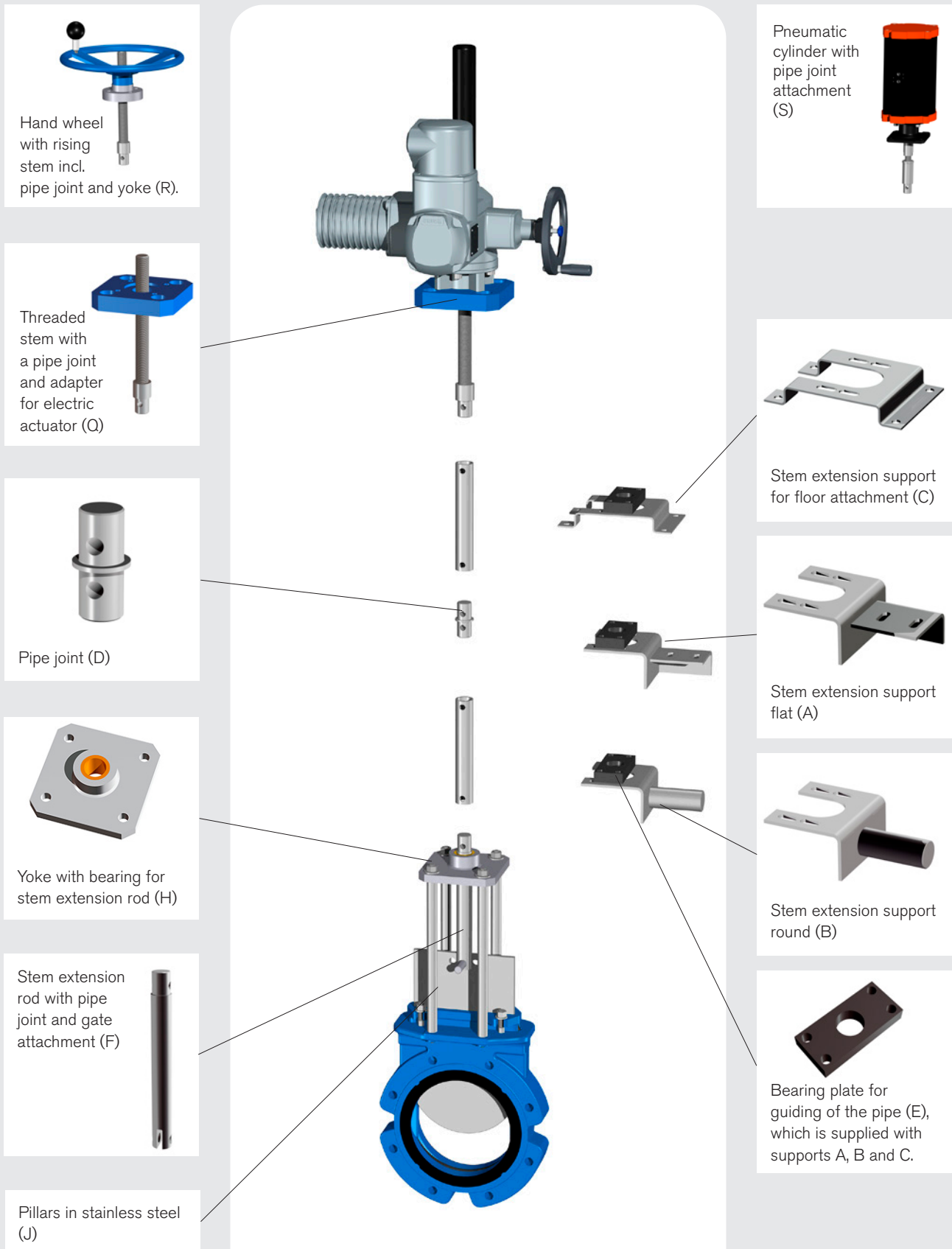

Screws, nuts and washers in stainless steel (A4) are included to connect the stem extension parts. Stem extension supports (A, B, C), pipe joint (D), stem extension rod (F) and pillars (J) are all supplied in stainless steel. The bearing plate (E) is supplied in HD-polyethylene. The supports (A, B, C, E) and pipe joint (D) can also be used for stem extension short. See each valve data sheet for material specifications on other parts.

Stem extension with a T-key

The top of the non-rising stem can be equipped with a cone-shaped adapter for T-key manoeuvring which is designed according to DIN 3223 C. The T-key adapter (N) and valve stem adapter (M) are supplied in stainless steel.

Details in T-key extension kit

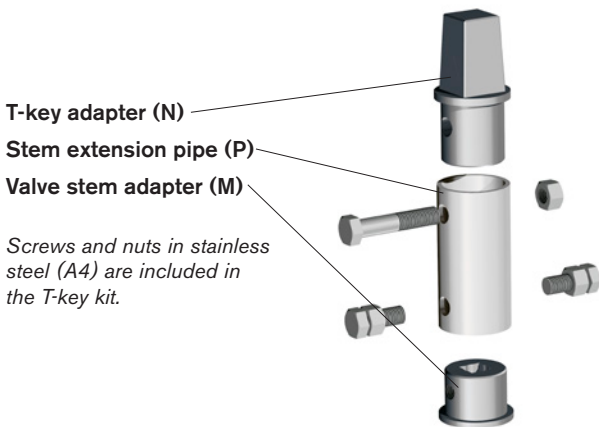

Minimum length of T-key adapter (mm)*

Minimum length	MV sizes	HG sizes	WB sizes	RKO sizes
135 (Tr 19)	50 - 150	80 - 150	80 - 150	100
155 (Tr 25)	200 - 300	200 - 250	200 - 300	150 - 250
175 (Tr 31,5)	350 - 400	300 - 350	-	300 - 350
180 (Tr 40)	450 - 600	400 - 600	-	400

* Measured from valve yoke to top of adapter.

Stem extension pipe

The stem extension pipe is available in three different sizes, depending on which valve type it will be used on and its size. Stafsjö can supply suitable pipe length, prepared with holes (S) for connection to the valve adapters with screws and nuts. As standard the pipe is supplied in stainless steel EN 1.4301.

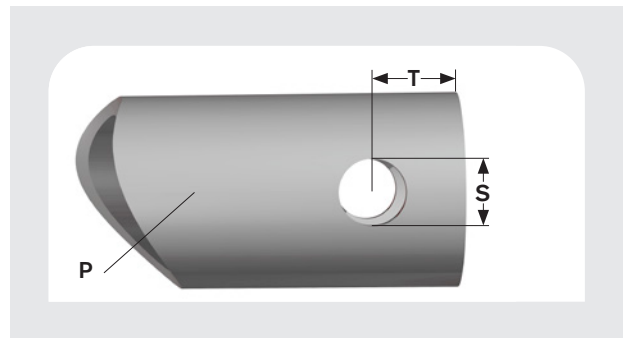

Recommended pipe sizes (mm)

Ø pipe (P)	Ø hole (S)	Distance (T)	MV sizes	WB sizes	HG sizes	RKO sizes
33,7 x 3,2	11	12	50 - 150	50 - 150	80 - 150	100
48,3 x 3,2	13	17	200 - 400	200 - 400	200 - 350	150 - 350
60,3 x 3,6	17	22	450 - 600	300 - 600	300 - 400	400

Floor column and actuator sizes

Recommended floor column (K) sizes

Ø pipe (P)	Floor column (K)	Maximum SC size	Maximum AUMA size
33,7 x 3,2	Small	SC 160	SA07.6
48,3 x 3,2	Small	SC 200	SA10.2
48,3 x 3,2	Large	SC 200	SA14.2
60,3 x 3,6	Large	SC 250	SA14.6

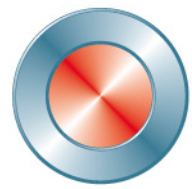

Stafsjö
SINCE 1666

www.stafsjo.com

STAFSJÖ
50005E



**Valve
& Automation**

Total Valve & Control Solutions®

JOHANNESBURG
Tel: 011 397 2833

South Africa:
0861 103 103

DURBAN
Tel: 031 579 2593

E-mail: sales@valve.co.za
www.valve.co.za



SCAN ME