

1. General

1.1 SAFETY

2. Assembly/disassembly of NAF-Triball

- 2.1 Welding-in NAF-Triball
- 2.2 NAF-Triball disassembly
- 2.3 NAF-Triball gland leakage
- 2.4 Screw torque specification (Nm)

3. NAF-Triball: Spares for new CE-marked valves

888X5X-XXXX-XX resp. 888X6X-XXXX-XX or versions thereof.

- 3.1 Spare parts and spare part kits
- 3.2 Ordering example

4. Material specification

5. NAF-Triball Sampling valve 8886X4-XXXX-XX

- 5.1 Welding-in of the sampling valve 8886X4-XXXX-XX
- 5.2 Connection plate for sampling 8886X4-XXXX-XX (previously 8887X4-XXXX)

1. General

Material specifications, various connections, measurements etc. are to be found in catalogue sheet Fk 25.622.



1.1 SAFETY

- Assess all the risks to eliminate the risk of personal injury and material damage. Read these instructions thoroughly!
- Always use the necessary protective equipment and comply with applicable safety directives when working with hazardous or hot/cold medium.
- Never operate a valve without first ensuring that there is no risk of crush injuries. The risk is highest with automatic valves.
- Take necessary safety precautions to prevent unintentional manoeuvre - i.e. to atmosphere.
- Never dismantle a valve or part of a valve without ensuring that the line is free of pressure and any content.
- Ball valves must always be dismantled in semi-open position to avoid trapping pressure and medium.
- Always check that the valve type and material is suitable for its intended use. This applies especially to highly oxidising and corrosive medium. Observe also the risk of erosion and explosion as well as decaying medium. If in doubt, always request a written recommendation from NAF AB.

2 Assembly/disassembly of NAF-Triball

Please keep special attention to the following:

- To simplify assembly and avoid unnecessary strain on the valve, i.e. pipe forces, always check that the pipes which the valve is to be welded between are parallel and have the same centre line.

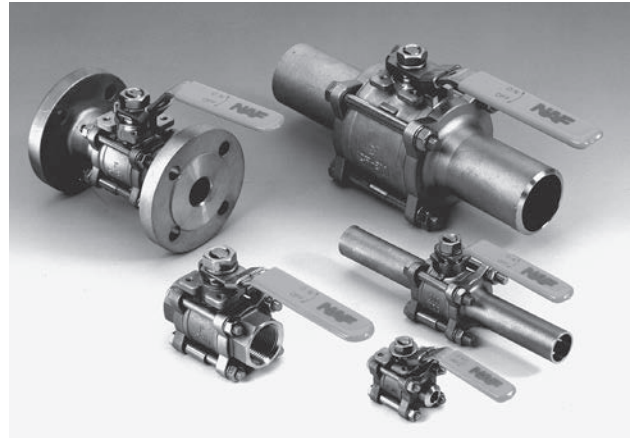

- Remember that damage to the seat ring can cause leakage. Always use great care when disassembling and reassembling the valves to avoid damage to the rings from contamination.

2.1 Welding-in NAF-Triball

- The version with long welding ends, **NAF 8886X3-XXXX-XX** and **NAF 8886X7-XXXX-XX** do not need to be disassembled before welding. **Note that the ball must be in the open position during welding.** The length of the welding ends is such that the temperature will not damage the interior of the valve.
- NAF-Triball with short welding ends, **NAF 8886X1-XXXX-XX** and **NAF 8886X4-XXXX-XX**, must be disassembled before welding. The valve body and its seatrings must be removed as described below and replaced with a suitable spacer, such as a body of the same DN but without internal parts. Screw the end pieces together and weld the unit into the pipe. After welding, refit the complete valve body and tighten the screws to specified torque, see below.
- The above applies on the condition that welding is done professionally and in accordance with applicable standards.

! After welding, both valves and connecting pipes should be cleaned from welding debris, scale etc.

Note: When re-assembling the valve, always use new body seals in order to simplify assembly and minimise risk for leakage.

2.2 NAF-Triball disassembly

1. Turn the ball to the open position. Remove one of the bolts (or stud) and release the other three.
2. Remove the body section.
3. Refit the body section after the planned action is carried out and tighten the bolts (or studs), see required torque as per table below. Use MoSo2 based grease to lubricate the threads on the bolts.

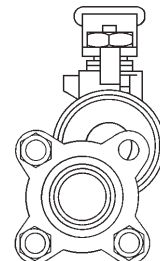
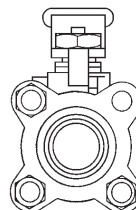

NAF Control Valves

2.3 NAF-Triball stem packing

1. If there is leakage through the stem packing, then retighten the gland nut until the leakage stops.
2. If the leakage continues the valve should be dismantled and the packing box exchanged. To facilitate dismantling and handling of valves in sizes DN 65-100 these valves are equipped with a support flange for the studs which are fitted into clearance holes in the top part of the body.

2.4 Screw torque specification (Nm)

DN	Req. torque
10	8-12
15	20-30
20	20-30
25	20-30
32	25-35
40	25-35
50	25-35
65	30-40
80	35-45
100	35-45

3 NAF-Triball: Spares for new CE-branded valves 888X5X resp. 888X6X or versions thereof.

3.1 Spare part kits

Hand lever

Pos 1 1 pc
Pos 2 1 pc

Stem sealing kit

Pos 6 1 pc
Pos 6A 1 pc
Pos 8 1 pc

Seat ring kit

Pos 9
Seatring 2 pcs
Back sealing 2 pcs

Ball

Pos 12 1 pc

3.2 Ordering example

Ordering of spare parts

When placing order for spare parts, please specify:

- NAF No and DN
- Requested qty
- Description of the part and item No.

These data are specified on NAF-Triballs identification plate.

Example: NAF 888657-0015-85, DN 15 , 1 pc
Seat ring kit, item No. 9A.

NAF Control Valves

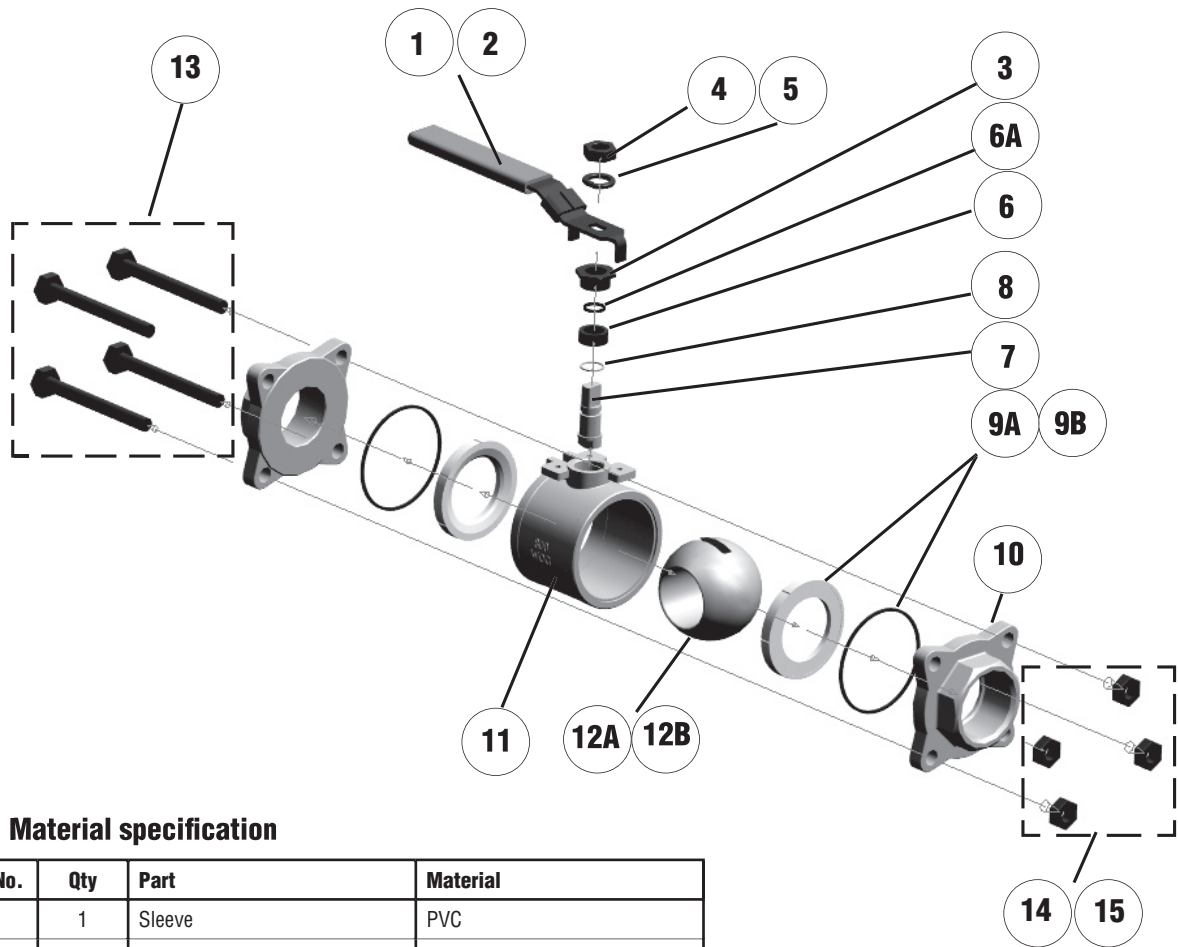

4 Material specification

Item No.	Qty	Part	Material
1	1	Sleeve	PVC
2	1	Lever	EN1.4301
3	1	Gland, DN ≤ 50 Gland, DN ≥ 65	EN1.4435 EN1.4301
4	1	Nut	A2
5	1	Washer	EN1.4301
6*	1	Box packing	PTFE, Virgin
6A*	1	O-ring	FPM
7	1	Stem	EN1.4435
8*	1	Bearing washer	PTFE
9A	2	Seat ring+ Body seal ring	PTFE, MG1241
9B	2	Seat ring+ Body seal ring	Alloy 6 + PTFE (seal)
10	2	End piece	EN1.4408
11	1	Body	EN1.4408
12A	1	Ball, standard	EN1.4435
12B	1	Ball, hard chrome facing	EN1.4435 + HCF
13	4	Hex screw DN ≤ 50 Stud, DN ≥ 65	A2 A2
14	4	Spring washer	EN1.4301
15	4	Nut	A2

NAF Control Valves

5 NAF-Triball Sampling valve 8886X4-XXXX-XX

These valves are aimed to be welded-in to a pipe to simplify sampling without plugging the valve up-stream. The valves pipe adapter/end piece is designed in order to minimise the risk for plugging in the inlet up-stream.

5.1 Welding-in of the sampling valve 8886X4-XXXX-XX

NAF recommend that assembly/welding-in should be performed as described in the following:

1. Disassemble the valve.
2. Use the pipe adaptor/end piece as a pattern and draw the outer line of the piece on to the pipe. See the outline of the inlet piece in the figure below.
3. Cut out the corresponding piece from the pipe. The exact dimensions can be seen in main dimension table below.
4. Fit in the inlet piece in to the cut out hole and tack weld it in the pipe
5. Complete the welding of the inlet piece according valid norms and standards
6. After completeing the welding reassemble the valve in opposite order as described in 1.

OBS: Never weld in the pipe adaptor piece when the valve is assembled. It will destroy the soft parts inside the valve

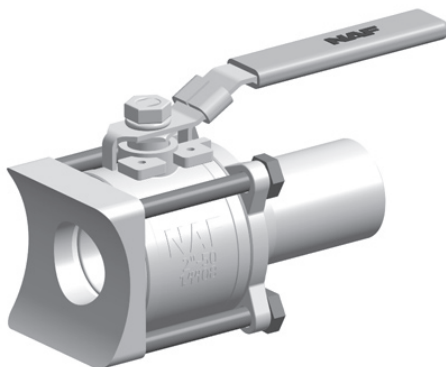

Valve 8886X4-XXXX-XX

5.2 Connection plate for sampling 8886X4-XXXX-XX (previously 8887X4-XXXX)

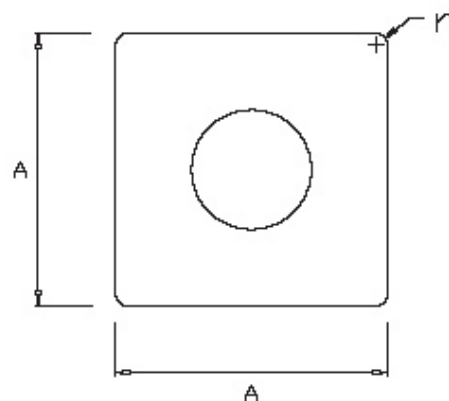
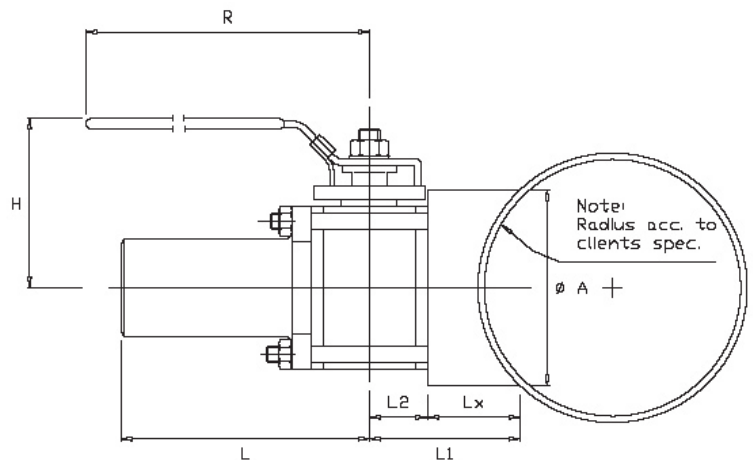

Valve dimensions with hand lever (mm)								
DN	R	H	L	L1	A	r	Lx	L2
10	96	48	107	31	41	4	20	10,5
15	124	54	112	28	50	6	25	13,25
20	124	57	118	37	54	6	25	16,5
25	142	64	124	45	60	8	25	19,5
32	142	70	130	52	72	8	27	25,0
40	202	86	143	65	80	8	35	29,5
50	202	93	152	72	100	8	35	37,25
65	250	139	162	83	122	10	40	43,05
80	250	150	172	99	140	10	50	49,4
100	300	160	183	105	Ø225 ¹⁾	- ¹⁾	45	60,05

¹⁾ Note: The largest size has a cylindrical end piece not square shaped as the smaller dim. Contact NAF for detailed dimensional info.