



# **NAF Control Valves**

## ***USER INSTRUCTIONS***

### ***NAF Trunnball DL Ball Valves***

FCD NFENIM4168-01-A4 01/15

***Installation  
Operation  
Maintenance***

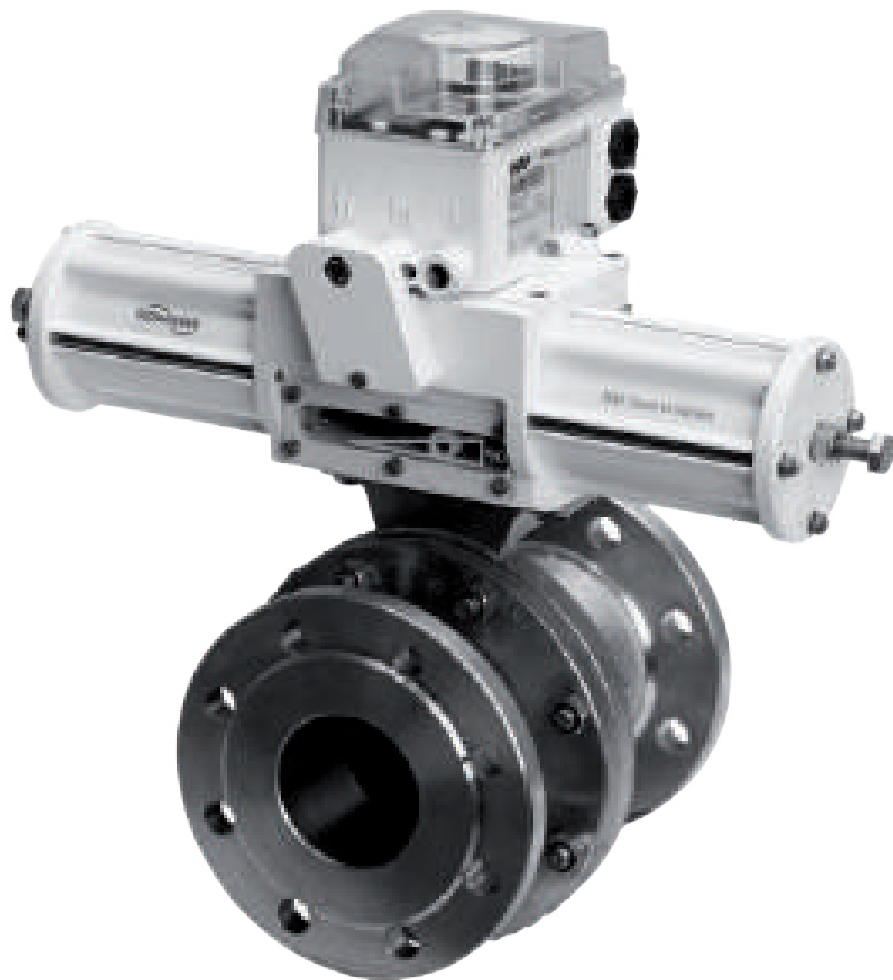

## Contents

SAFETY	3
1 General	3
2 Lifting	4
3 Receiving Inspection	4
4 Installation	4
5 Commissioning	4
6 Bill of Materials and Recommended Spare Parts Kits	5
7 Ordering of Spare Parts	6
8 Maintenance	6
8.1 Removing the valve from the pipework	6
8.2 Disassembling the valve for inspection and replacement of ball, seats and stem packing	6
8.3 Valves with PTFE seat rings	7
8.4 Valves with hard chrome plated ball and seat rings in Alloy 6	8
8.5 Valves with ball and seats in Alloy 6	8
8.6 Changing the stem packing	8
9 Fitting an Actuator to the Valve	9



## SAFETY

- Assess all risks to eliminate the possibility of personal injury and material damage. Read these instructions thoroughly.
- Always use the necessary protective equipment and comply with applicable safety directives when working with hazardous or hot/cold media.
- Never operate a valve without first ensuring there is no risk of crush injuries. The risk is highest with automated valves. Take necessary safety precautions to avoid unintentional stroking of the actuator / valve.
- Never dismantle a valve or part of a valve without ensuring the line is free of pressure and media.
- Ball valves must always be dismantled in the semi-open position to avoid trapping pressure and media.
- Always check that the valve type and material is suitable for its intended use. This applies especially to highly oxidizing and corrosive media. Observe also the risk of erosion or explosion, as well as decaying medium. If in doubt, always request a written recommendation from Flowserve.

## 1 General

This instruction provides necessary information for the correct handling of the NAF Trunnball DL ball valve. For additional equipment used together with the valve, please refer to their corresponding instructions.

Although this instruction is made to cover a broad range of varieties of the NAF Trunnball DL, there will inevitably be versions not covered in detail. If you have any doubt about the correct use and handling of a specific version of NAF Trunnball DL, please contact your Flowserve representative.



**Valves intended for use on highly oxidizing media are often delivered in a degreased version. Any valve marked with “Degreased for oxygen service” must be handled with the greatest care and be protected from being contaminated with grease, dust or anything else that can jeopardize its safe use.**

The instructions and list of spare parts in this document are applicable to NAF Trunnball DL ball valves in accordance with our technical bulletin.

## 2 Lifting

All lifting must be carried out on the valve itself and not on the actuator. The mounting connection between the valve and the actuator is designed principally for carrying the operating torque and the deadweight of the actuator and is not designed to support the weight of the valve. See Figure 1.

Figure 1 – Lifting of the valve

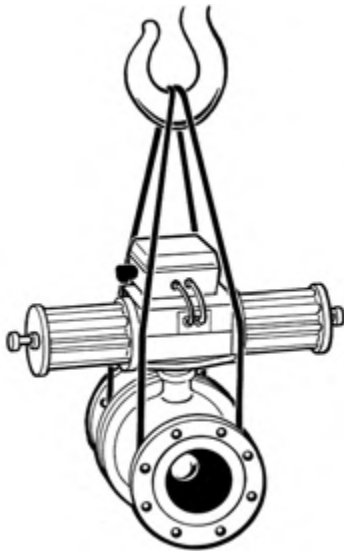

## 3 Receiving Inspection

All valves leaving our facility are inspected and tested in accordance with the relevant requirements or in accordance with the special provisions specified by the purchaser. Valves equipped with actuators are subjected to functional testing and are adjusted in such a manner that every unit is ready for direct installation in the pipework. However, because damage may have occurred during transport, it is advisable that receiving inspection be carried out.

We suggest the following inspection procedure:

- Check that the valve delivered is correct in terms of type, size, equipment, etc.
- Examine the valve, actuator and valve positioner for possible damage.

## 4 Installation

Before installing the valve, ensure the pipework is free from impurities, that the pipe end connectors between which the valve is to be installed are parallel and are correctly aligned, and that the distance between the pipe ends correspond to the valve length, including gaskets. The valve must not be used for drawing together or aligning incorrectly run pipes as this will cause improper loads on the valve and pipe which could lead to problems during operation. See Figure 2.

Figure 2 – Ensure that the pipe ends align and have the correct gap

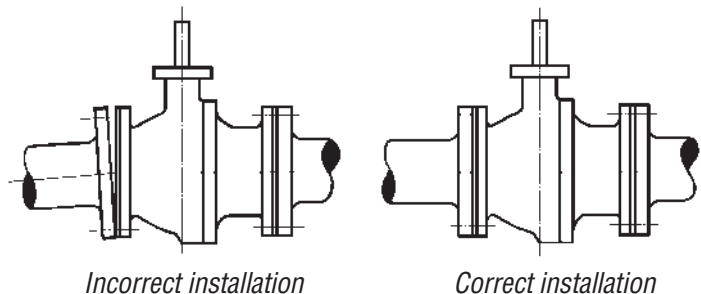

**NAF Trunnball DL valves can be installed in any orientation** and for either direction of flow.

However, we recommend that if installed in a horizontal run of pipe, the valve should be mounted with the stem pointing vertically upwards.

**The pipes should be supported on each side of the valve** in order to relieve the valve of unnecessary loads and avoid vibrations.

**Locate the valve so it will be easily accessible** for inspection and service, particularly if the valve is equipped with an actuator and a valve positioner.

## 5 Commissioning

Before starting up, flush the pipework with all valves in the open position so that any impurities that may damage the sealing surfaces of the valve or impede its operation will be flushed away.

# NAF Control Valves

NAF Trunnball DL Ball Valves NFENIM4168-00-A4 01/15

Figure 3

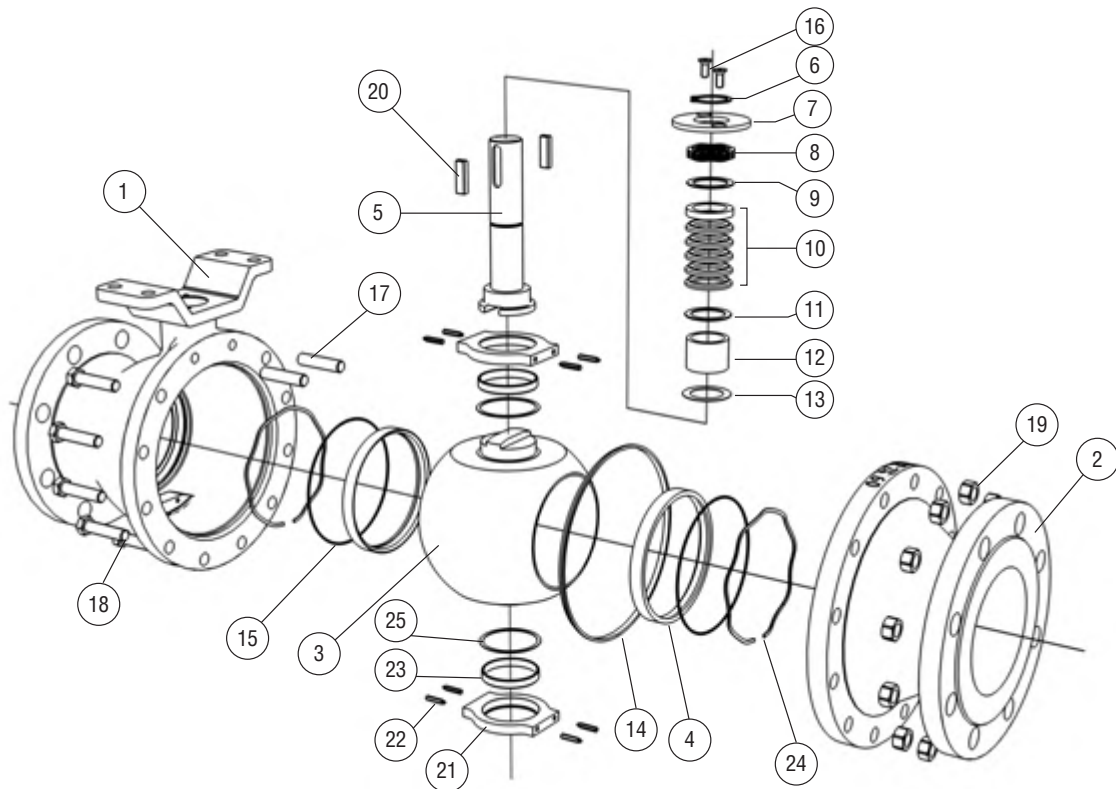

## 6 Bill of Materials and Recommended Spare Parts Kits

Item	Qty	Part	Kit A Stem sealing kit	Kit B Seat ring kit (soft seated)	Kit C Ball kit (soft seated)	Kit D Seat and ball kit (metal seated)	Kit E Seat seal kit	Kit F Bearing kit	Kit G Seat spring kit
1	1	Body, main							
2	1	Body, cover							
3	1	Ball			X	X			
4	2	Seat ring		X		X			
5	1	Stem							
6	1	Circlip	X						
7	1	Cover							
8	1	Spring	X						
9	1	Washer	X						
10	1	Stem packing	X						
11	1	Washer	X						
12	1	Bushing	X						
13	1	Anti-friction washer	X						
14	1	Body seal	X						
15	2	Seat seal		X		X	X		
16	*	Screw							
17	2	Stud							
18	*	Bolt							
19	*	Nut							
20	2	Key							
21	2	Trunnion plate							
22	8	Pin							
23	2	Trunnion bearing						X	
24	2	Spring							X
25	2	Bearing washer						X	

\* Quantity depending on size of the valve.

Material and design of the parts vary depending on the version of the valve. Version is determined by NAF No. on the identification plate of the valve.

## 7 Ordering of Spare Parts

When placing an order for spare parts, specify:

- NAF-No: specified on the identification plate of the valve.
- Recommended spare part kit according to section 6.
- Quantity required.

Ordering example:

NAF-No: 8985KF-0200-BABAEA  
Spare part kit: A  
Quantity: 1pc

## 8 Maintenance

Many valves are installed in locations where their performance is of critical importance to the entire process. Such valves should be inspected regularly and any issues should immediately be corrected.

**⚠ Valves intended for use on highly oxidizing media require special handling, such as cleanliness and use of special grease, to avoid safety hazards. Applicable regulations must be followed and the following maintenance instructions can therefore only serve as general guidance.**

### 8.1 Removing the valve from the pipework

The procedure for inspection and maintenance requires no special tools.

**⚠ Ensure the process line is shut off, free of pressure and drained of media.**

- 1 Ensure that the recommended spare parts and gaskets for the pipe flanges are available.
- 2 Before removing the valve from the pipeline, operate it several times between the open and closed position to ensure that any trapped media / pressure is released.

- 3 Shut off all compressed air connections and isolate all electrical connections to the actuator.
- 4 Disconnect all compressed air lines and electric cables connected to the actuator.

**⚠ Caution. Liquid in the valve may be harmful.**

- 5 Release the flanged joint between the valve and the pipework. Then lift out the valve. Don't use the actuator for lifting. **Apply all lifting forces to the valve itself and not to the actuator.** See Figure 1.

### 8.2 Disassembling the valve for inspection and replacement of ball, seats and stem packing

For part numbers, refer to Figure 3.

- 1 **The actuator does not need to be removed** for replacing the seat rings and ball. However if the stem seal is leaking, the stem packing must be replaced. Even if the stem seal does not leak, we always recommend replacing the stem packing every time the valve is disassembled. This will prevent unnecessary extra work and downtime caused by a stem leakage in the future. We always recommend the use of a stem sealing kit, spare part kit A.
- 2 Operate the valve to make **certain that it is completely empty of process media**. Close the valve.
- 3 Remove the body cover (2).

*Figure 4 – Lifting the ball with the valve in closed position – here with the valve on a work bench, but it can be done with mounted actuator*

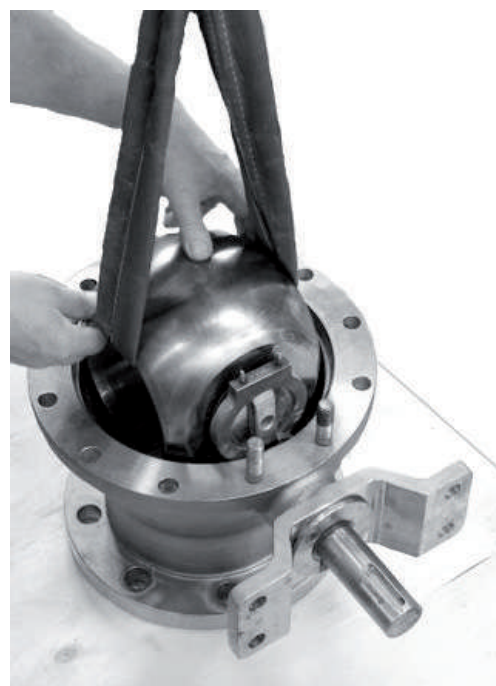

- 4 Remove the ball (3), trunnion plates (21) and bearing washer (25), which is simple to do when the valve is in the closed position. See Figure 4.
- 5 Remove the trunnion plates (21), trunnion bearing (23) and bearing washer (25) from the stub shafts of the ball (3).
- 6 Carefully inspect the ball (3) and seat rings (4).
- 7 Clean all parts thoroughly. First use hot water and then degreasing agent, if necessary. Don't scrape any of the machined surfaces with hard tools.

## 8.3 Valves with PTFE seat rings

- 1 To ensure tightness of the valve, change the seat rings (4), springs (24) and seat seal (15) if they are worn or damaged.
- 2 For the main body (1): Fit seat seal (15) into the groove in the main body (1) and place the spring (24) into the seat area. Put some silicone grease on the surface of the seat seal (15) and gently press the seat ring (4) down.
- 3 For the body cover (2): Fit seat seal (15) into the groove in the body cover (2) and place the spring (24) into the seat area. Put some silicone grease on the surface of the seat seal (15) and gently press the seat ring (4) down.

**Note:** If the valve is intended for service in an oxygen system a grease suitable for oxygen service must be used

- 4 Inspect the ball (3). Minor damage to the sealing surface can be removed by polishing with fine emery cloth. If the ball has major damage, it must be replaced to ensure satisfactory tightness.
- 5 Fit a new trunnion bearing (23) in each of the trunnion plates (21).
- 6 Place a new bearing washer (25) onto each of the stub shafts of the ball. Directly thereafter put the trunnion plates (21) over the bearings washer (25) on each side of the ball (3).
- 7 Place the main body (1) on a work bench with the pipe flange facing down. Lower the ball (3), including the trunnion plates (21), into the main body (1) see Figure 4. Make sure that the four pins (22) are still fitted in the main body (1) with the tapered end facing up, and check that the pins enter into the corresponding holes in the trunnion plates (21).
- 8 With the ball assembly in place in the main body (1), put the remaining four pins (22) into the trunnion plates (21) with the tapered end facing up.
- 9 Put a new body seal (14) on the body cover (2) so the sharp end will face the main body (1) when assembled.

- 10 Lower the body cover (2), onto the main body (1). Note: The main body (1) and body cover (2) will only fit in one position.
- 11 Lubricate the contact surfaces of the nuts (19), and the threads of the studs/bolts (17, 18), with suitable anti-seizing grease and put the nuts onto the studs/bolts.
- 12 Tighten the bolted joint of the two body halves (1, 2) alternately in several stages, and finally tighten according to the torque as below.

Bolt	Torque Nm	Bolt	Torque Nm
M12	76	UNC ½"	89
M16	187	UNC 5/8"	175
M20	364	UNC ¾"	308
M24	629	UNC 7/8"	493
M30	1240	UNC 1"	737

- 13 Operate the valve between closed and open positions.
- 14 If possible, pressure test the valve with water to check its tightness. See Figures 5 and 6.

**⚠ Testing with gaseous media is not recommended due to safety issues. Make sure that the cavities of the valve are properly filled with liquid before pressure testing. This is most easily done by placing the valve in the vertical position and filling the valve in the semi open position with liquid.**

**⚠ Testing the valve body tightness (5) should not be performed at a pressure higher than 1.5 x maximum allowed working pressure. Refer to Technical Bulletin NFENTB4168**

**⚠ Testing of the ball and seat tightness (6) should not be performed at a pressure higher than 1.1 x maximum allowed differential pressure (see Technical Bulletin).**

**As the seat needs a certain amount of flow to seal against the ball, we recommend that the inlet pipe connection is a minimum of 25 mm/1".**

- 15 If the valve has been pressure tested, please check and, if needed, re-tighten the bolts according to 8.3.12.

## 8.4 Valves with hard chrome plated ball and seat rings in Alloy 6

- 1 Check the sealing surfaces of the seat rings (4). Minor damage to the seats can be rubbed down with fine emery cloth. Check the seats on a face plate to ensure that they are perfectly flat. Don't lap the seats and the chromium-plated ball together. Change the seats if they are severely damaged.
- 2 Inspect the sealing surface of the ball (3). Minor damage may be rubbed down with fine emery cloth. If the existing ball must be used for a further period of time, remove all sharp edges, dents and irregularities with a fine file or emery cloth. If the ball is severely damaged, the ball must be replaced.
- 3 Grease the ball (3) with a suitable grease, such as Klüber Unisilicone L641 or similar.

**Note:** If the valve is intended for service in an oxygen system a grease suitable for oxygen service must be used.

- 4 Continue assembling the valve as described in items 2–15 in section 8.3.

Figure 5 – Testing of body tightness

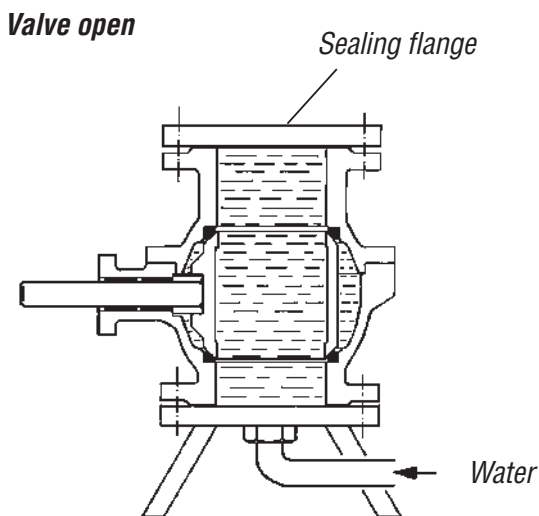
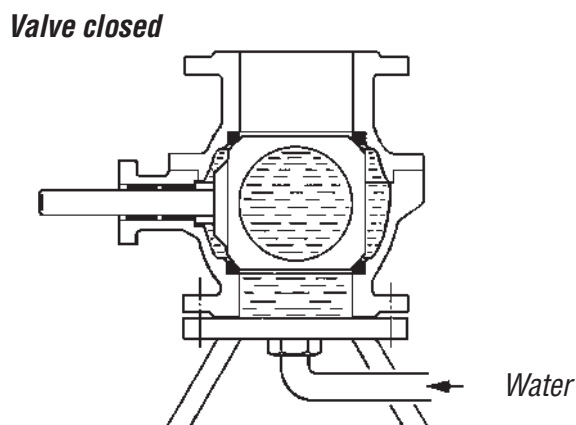

Figure 6 – Testing of ball and seat tightness



## 8.5 Valves with ball and seats in Alloy 6

- 1 The instructions for these valves are the same as those in section 8.4. If the sealing surfaces are damaged, we recommend that the valve is returned to Flowserve for overhaul. This applies in particular if the ball must be ground before lapping. Assemble the valve before dispatching it to Flowserve.
- 2 The ball (3) and seat rings (4) can be temporarily overhauled by lapping them together. This can be done manually with a compound with grit size 200. Take great care to ensure that the ball and seat rings do not become oval.
- 3 Balls in Alloy 6 must be carefully cleaned and greased before they are fitted. Use a suitable solvent for cleaning. Then grease the ball with Klüber Barrierta L55/3 H8 or similar. This coat of grease must be very thin.

**Note:** If the valve is intended for service in an oxygen system a grease suitable for oxygen service must be used.

## 8.6 Replacing the stem packing

If the stem seal is leaking, the stem packing must be replaced. Even if the stem seal does not leak, we always recommend replacing the stem packing every time the valve is disassembled. This will prevent unnecessary extra work and downtime caused by a stem leakage in the future. We always recommend the use of a stem sealing kit, spare part kit A.

**⚠ Make sure that the valve is not under pressure.**

- 1 Remove any actuator.
- 2 Remove the keys (20).
- 3 Remove the circlip (6), back off the screws (16), and remove the cover (7) and the spring (8).
- 4 Disassemble the valve as described in section 8.2.
- 5 Press the stem (5) down into the body and remove it.
- 6 Press the bushing (12) down into the body and remove it.
- 7 Remove the stem packing (10) and washers (9) and (11). See Figure 7.

Figure 7 – Stem packing for standard (left) and fire-safe version (right)

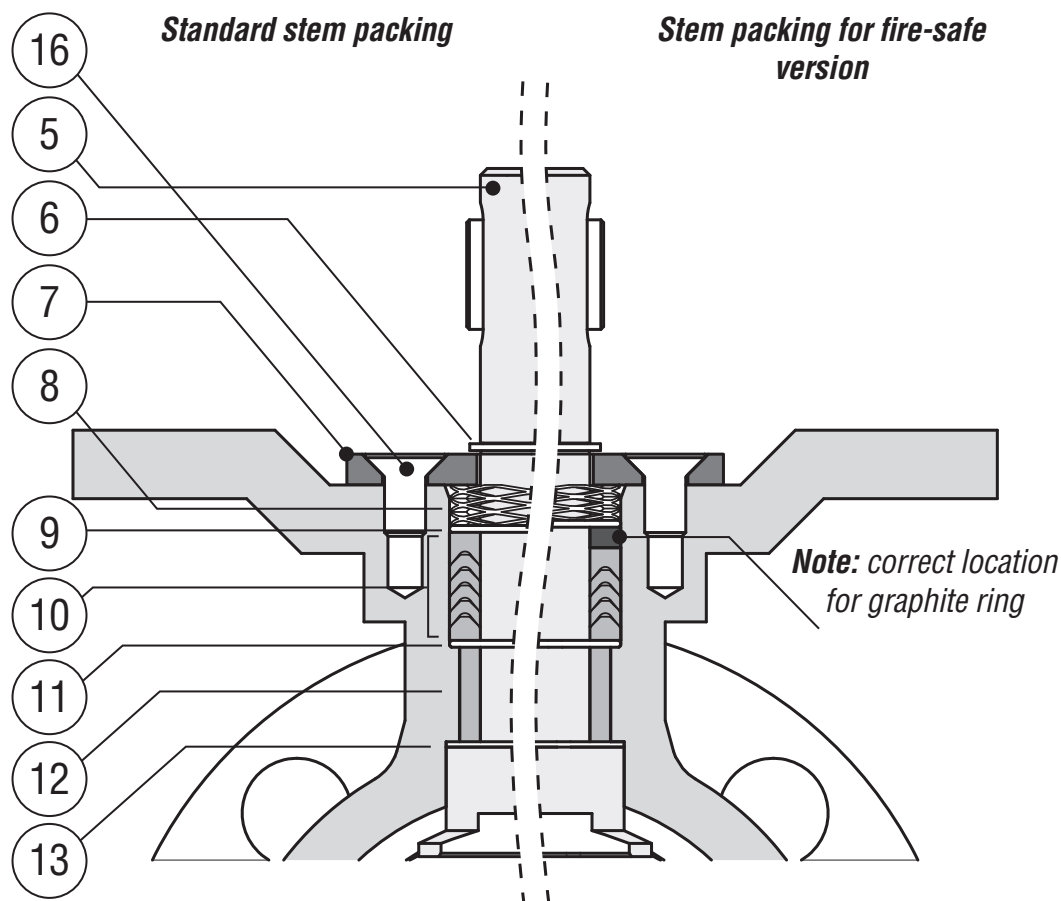

- 8 Fit a new anti-friction washer (13) to the stem (5) followed by a new bushing (12). Then fit the stem assembly (5, 12, 13) into the valve body.
- 9 Fit washer (11) and a new stem packing (10) using a suitable silicon grease.  
**Please note that for valves in a fire-safe version, the graphite ring of the stem packing (10) must be placed on top of the stem packing. See right part of Figure 7.**
- 10 Fit washer (9) and spring (8).
- 11 Fit cover (7) and tighten the screws (16) alternately in several stages.
- 12 Fit the circlip (6).
- 13 Assemble and, if possible, pressure test, the valve as described in section 8.3.

## 9 Fitting an Actuator to the Valve

- 1 Fit the actuator to the valve. Ensure that both the valve and the actuator are in the closed position before fitting the actuator. The valve is in the closed position when the keys (20) in the stem (5) face in the direction of flow. (An actuator which uses compressed air to close the valve and a return spring to open the valve should be fitted with the actuator and valve in the open position.)
- 2 Check the operation and check that the end stops have been correctly preset or adjust them so the ball is in the correct position.

**Note:** The direction of closure must always be clockwise, as viewed from the actuator.

# NAF Control Valves

*NAF Trunnball DL Ball Valves NFENIM4168-00-A4 01/15*

*Page intentionally left blank*

# NAF Control Valves

*NAF Trunnball DL Ball Valves NFENIM4168-00-A4 01/15*

*Page intentionally left blank*

# NAF Control Valves



**JOHANNESBURG**  
Tel: 011 397 2833

**DURBAN**  
Tel: 031 579 2593

**South Africa:**  
**0861 103 103**

E-mail: [sales@valve.co.za](mailto:sales@valve.co.za)  
**[www.valve.co.za](http://www.valve.co.za)**

