



AUTOMATION AND DIGITALIZATION

# NAF SETBALL BALL SECTOR VALVES FOR MC-PULP

TECHNICAL BULLETIN



**ANDRITZ**

ENGINEERED SUCCESS

# Primary characteristics

NAF Setball for MC-pulp is a ball sector valve with metal-to-metal seating and combines the best control characteristics of the ball valve and the butterfly valve. It can be used both as control valve and as shut-off valve and is available in flanged version. This valve type is developed for MC-pulp 8-19%. It has an enlarged outlet with one size bigger flange on the outlet to get an excellent flow characteristic for the MC-pulp out of the valve. It is available as standard in 1.4408/CF8M, CG8M and SMO254. Contact NAF for more information.

## The valve has:

- a one-piece, leak-proof body.
- a ball sector with top and bottom bearings for low operating torque which makes it possible to use low-torque actuators.
- a V-shaped sector that provides accurate control over a wide range even at low flow rates and with MC-pulp (8-19%).
- a spherical area of the ball sector which, together with the seating sealing in alloy 6 and the design of the sealing package, ensures excellent tightness at both low and high differential pressure. The maximum leakage in the flow direction is less than  $5 \times 10^{-6}$  of the Kv value.
- PTFE lined stem bearings.
- The seat ring in alloy 6 is spring loaded against the ball sector.
- Stem sealing with o-ring or v-ring packing in PTFE.
- NAF standard for mounting the actuator, which simplifies installation and gives a compact valve/actuator unit.

CE-marked according to Pressure Equipment Directive (PED 97/23/EG) module H, category III.  
For module H1, category IV contact NAF

## TECHNICAL SPECIFICATIONS FOR STANDARD DESIGN

<b>Material</b>	EN 1.4408
<b>Size range</b>	DN 80-300
<b>Pressure ratings</b>	PN 16, 25 and 40 ANSI Class 150 and 300
<b>Max. differential pressures</b>	
<b>Valve closed</b>	25 bar DN 80-300
<b>Control service</b>	25 bar DN 80 15 bar DN 100-150 10 bar DN 200-250 8 bar DN 300 See also page 2
<b>Valve design</b>	ANSI B 16.34 and EN 12516
<b>Installation methods</b>	Flanged
<b>Temperature range</b>	-30 - 250°C
<b>Test pressure</b>	1.5 x PN with valve open. IEC 534-4 Class IV-S1 with valve closed
<b>Sealing class</b>	Testing medium is water. Seat in alloy 6



# Applications

NAF Setball can be used both as control valve and as shutoff valve and is developed for applications with MC-pulp 8-19%. It is primarily used for mounting directly on the flange of the MC-pump and on pulp distributors.

The valve is designed to give the MC-pulp a good flow through the valve. It represents a concrete result of our product philosophy which is focused on functionality, high quality and low life cycle costs, and is based on concentrating our range to a limited number of valve types, but all of them suitable for a wide variety of applications.



# Working pressures and temperatures

The maximum working pressure and temperature in the body depend on pressure class according to respectively flange standard. Max. differential pressure, valve closed, depends on temperature as shown in the diagram and is valid for all sizes. Max. differential pressure for control service and for sizes DN 100–300 depends on size and temperature as shown in the diagram.

## MAX WORKING PRESSURE

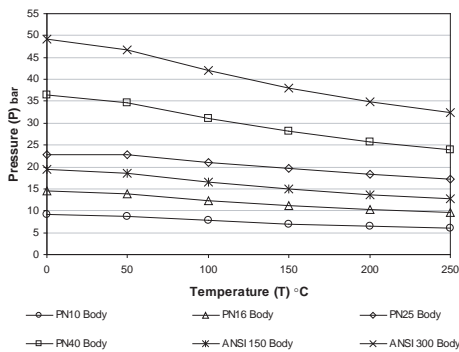

## MAX DP

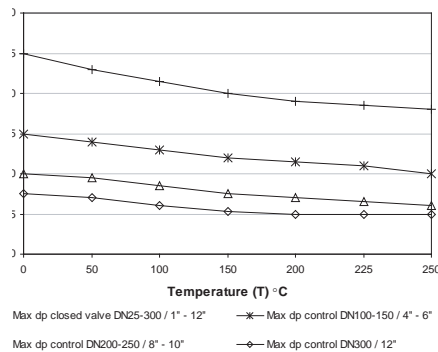

TABLE 1: FLOW CAPACITIES AND CHARACTERISTICS

DN/ Norm. Bore	Kv at an opening angle of								
	15°	20°	30°	40°	50°	60°	70°	80°	90° *
80	4	8	18	32	52	78	110	150	245
100	9	15	31	53	83	124	180	254	415
150	25	40	78	135	212	310	445	615	970
200	30	50	110	200	310	470	670	920	1250
250	33	80	200	337	575	830	1150	1560	2480
300	87	173	390	655	995	1410	1930	2580	3960

$C_v = 1.16 \times K_v$

\* At demand for larger max Kv contact NAF.



# Materials of construction

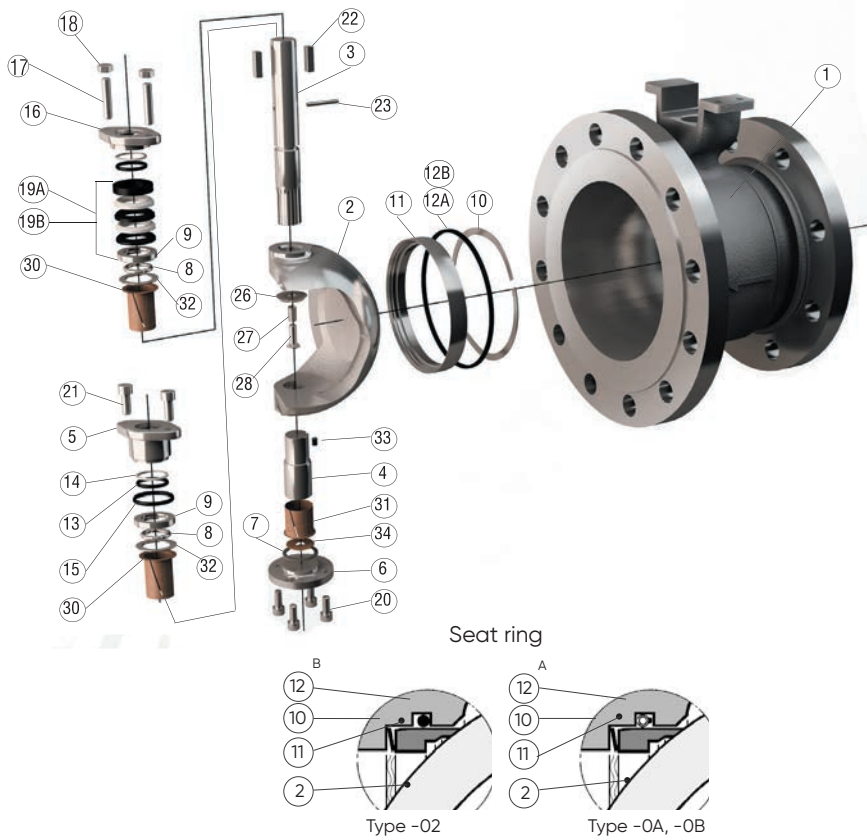

**TABLE 2: MATERIAL SPECIFICATION**

Item	Qty	Part	Material	Sealing type	Item	Qty	Part	Material	Sealing type
1	1	Body	EN1.4408/ CF8M	02, 0A, 0B	17	2	Bolt	A4	0A, 0B
2	1	Ball sector	EN1.4408/ CF8M hard chrome pl.	02, 0A, 0B	18	2	Nut	A4	0A, 0B
3	1	Stem, upper	EN1.4460	02, 0A, 0B	19A	1	Box packing Zebra-CL™	V-ring PTFE	0A
4	1	Stem, lower	EN1.4460	02, 0A, 0B	19B	1	Box packing Safeguard	V-ring PTFE liveloaded	0B
5	1	Gland cover	EN1.4408/ CF8M	02	20	4	Bolt	A4	02, 0A, 0B
6	1	Bottom cover	EN1.4408/ CF8M	02, 0A, 0B	21	2	Bolt	A4	02
7	1	Gasket	Graphite	02, 0A, 0B	22	1	Key	A4	02, 0A, 0B
8	1	Locking segment	EN1.4436	02, 0A, 0B	23	1	Indicating pin	SS	02, 0A, 0B
9	1	Bearing seat	EN1.4460	02, 0A, 0B	24	1	Cup spring Safeguard	EN1.4310	0B
10	1	Compr spring	EN1.4436	02, 0A, 0B	26	1	Washer	A4	02, 0A, 0B
11	1	Seatrings	Alloy 6	02, 0A, 0B	27	1	Thread insert	Stainless steel	02, 0A, 0B
12A	1	Seat seal	PTFE	0A, 0B	28	1	Bolt	A4	02, 0A, 0B
12B	1	Seat seal	EPDM	02	30	1	Stem bearing	PTFE lined	02, 0A, 0B
13	1	O-ring	EPDM	02	31	1	Stem bearing	PTFE lined	02, 0A, 0B
14	1	Backing ring	PTFE	02	32	1	Washer	A4	02, 0A, 0B
15	1	O-ring	EPDM	02	33	1	Cylindrical pin	EN1.4460	02, 0A, 0B
16	1	Gland cover	EN1.4408/ CF8M	0A, 0B	34	1	Washer	PTFE lined	02, 0A, 0B

# Operating torque

The minimum design torque for selecting the actuator is stated in the table for a differential pressure of 3 bar. The specified torques are for MC-pulp 8-19%.

**TABLE 3: OPERATING TORQUE, NM**

DN	Differential pressure bar				
	3	10	15	20	25
80	30	60	75	100	120
100	40	75	110	140	170
150	95	195	265	340	410
200	175	385	525	670	815
250	315	675	940	1190	1450
300	540	1110	1520	1920	2340

## Sizing of control valves

We have a user friendly valve calculation program which can be ordered through your NAF representative. The program is based on calculating formula according to the standards IEC 60534 and ISA S75.01.

# Dimension and mass

## FLANGED VERSION

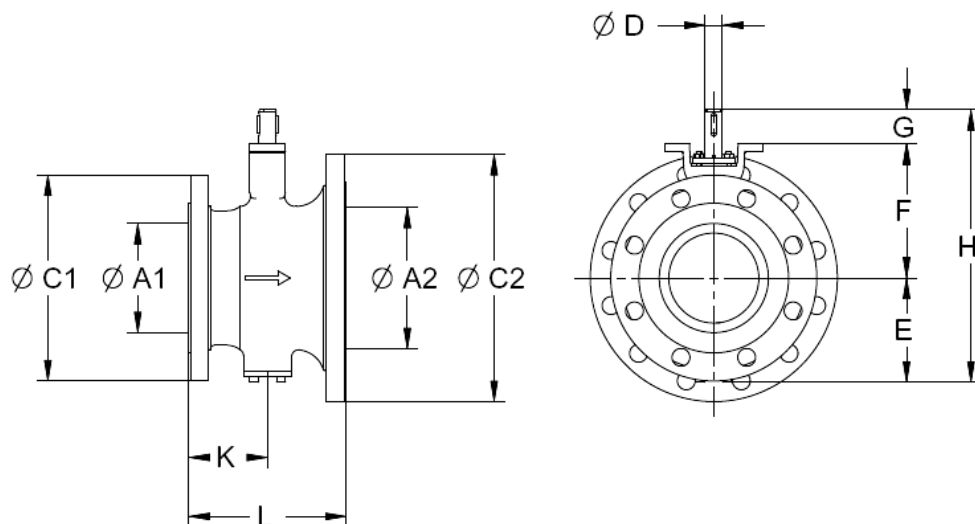

## NAF STANDARD FOR ACTUATOR MOUNTING

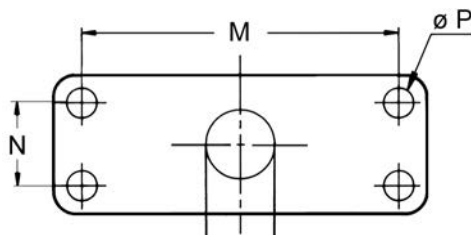

TABLE 4

DN	A1	A2	Inlet flange C1 <sup>1)</sup>	Outlet flange C2 <sup>1)</sup>	D	E	F	G	H	K	L	M	N	P	Mass kg <sup>2)</sup>
80	70	109	DN80 <sup>1)</sup>	DN100 <sup>1)</sup>	20	110	145	43	300	83	165	115	30	11	19
100	86	150	DN100 <sup>1)</sup>	DN150 <sup>1)</sup>	20	120	167	43	332	97	194	115	30	11	30
150	131	206	DN150 <sup>1)</sup>	DN200 <sup>1)</sup>	25	155	195	50	400	115	229	115	30	11	48
200	170	250	DN200 <sup>1)</sup>	DN250 <sup>1)</sup>	30	185	236	59	480	130	303	160	40	14	80
250	207	300	DN250 <sup>1)</sup>	DN300 <sup>1)</sup>	35	230	295	65	590	155	338	160	40	14	166
300	256	350	DN300 <sup>1)</sup>	DN350 <sup>1)</sup>	40	260	320	80	660	183	383	214	60	18	181

1) See respectively PN for flange diameter according to Fk 90.20

2) For PN25

All dimensions in mm

# Actuators

NAF Setball for MC-pulp is available with pneumatic or electric actuators and accessories. Use the following tables for selecting the standard pneumatic actuators. If other pneumatic or electric actuators are required, consult your NAF representative.

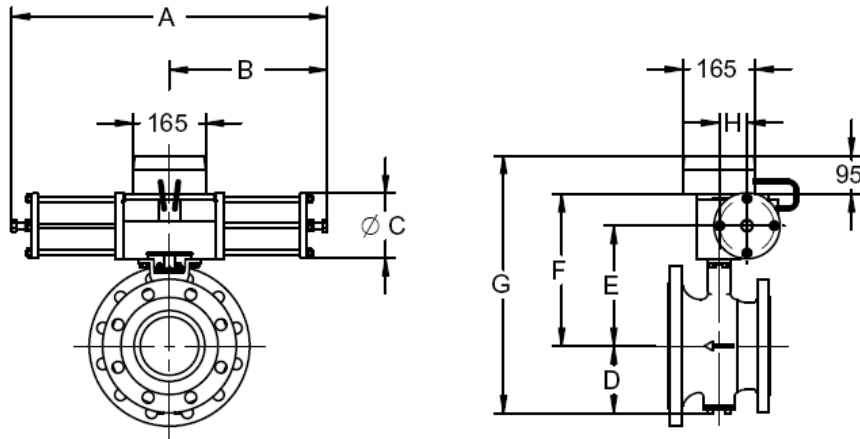

791290

**TABLE 5: NAF SETBALL FOR MC-PULP WITH PNEUMATIC ACTUATOR**

Valve DN	Max dP bar			NAF No.	Dimensions in mm								Mass kg <sup>2)</sup>
	4 bar	5 bar	6 bar		A	B	C	D	E	F	G <sup>1)</sup>	H	
Double acting according to Fk 74.59													
80	16	20	25	791390-0220	370	185	80	110	195	247	452	31	23
100	11	14	16	-0220	370	185	80	120	217	269	484	31	34
100	23	25	25	791290-1220	490	245	100	120	222	279	493	40	36
150	8	10	13	-1225	490	245	100	155	250	306	556	40	54
150	25	25	25	-2225	700	350	145	155	278	343	633	63	65
200	18	10	13	-2130	700	350	145	185	310	383	663	63	97
200	19	24	25	-2230	700	350	145	185	310	383	663	63	97
250	9	12	15	-2235	700	350	145	230	370	443	768	63	183
250	17	22	25	-3135	820	410	200	230	395	495	820	75	195
300	4	6	8	-2240	700	350	145	260	395	466	821	63	198
300	21	25	25	-3240	820	410	200	260	420	520	875	75	210

The dP mentioned below is valid for MC-pulp.

For other media contact NAF, see also page 4.

<sup>1</sup> Including NAF valve positioner

<sup>2</sup> For PN25

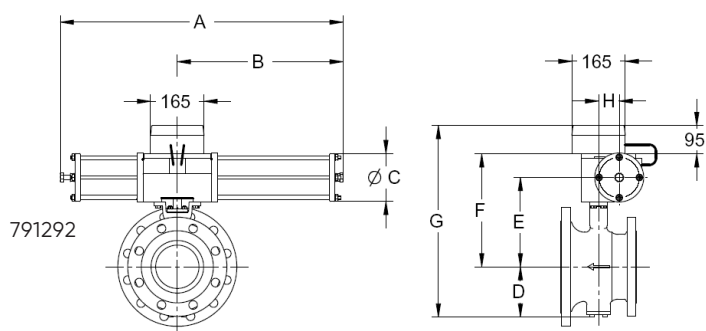

**TABLE 6: NAF SETBALL FOR MC-PULP WITH PNEUMATIC ACTUATOR**

Valve DN	Max. dp bar			NAF No.	Dimensions in mm								Mass kg <sup>2)</sup>
	4 bar	5 bar	6 bar		A	B	C	D	E	F	G <sup>1)</sup>	H	
Single acting, spring to close according to Fk 74.59													
80	4	10	15	791392-0220	455	270	80	110	195	247	452	31	22
80	17	25	25	791292-1220	635	390	100	110	200	257	462	40	30
100	12	17	22	-1220	635	390	100	120	222	279	493	40	39
100	25	25	25	-2220	890	540	145	155	270	343	593	63	53
150	-	5	7	-1225	635	390	100	155	250	306	556	40	57
150	21	25	25	-2225	890	540	145	155	270	343	593	63	71
200	9	14	19	-2230	890	540	145	185	310	383	663	63	103
200	25	25	25	-3230	1050	640	200	185	336	436	716	75	123
250	4	6	11	-2235	890	540	145	230	370	443	768	63	189
250	18	25	25	-3235	1050	640	200	230	395	495	820	75	209
300	10	17	22	-3240	1050	640	200	260	420	520	875	75	224
300	25	25	25	791392-4240	1520	965	260	260	448	580	915	100	281

1 Including NAF valve positioner

2 For PN25

The dP mentioned below is valid for MC-pulp.

For other media contact NAF, see also page 4.

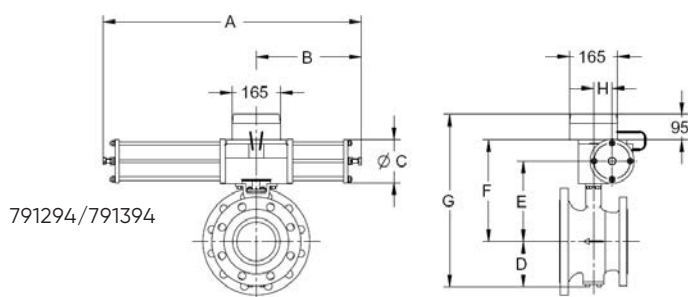

**TABLE 7: NAF SETBALL FOR MC-PULP WITH PNEUMATIC ACTUATOR**

Valve DN	Max. dp bar			NAF No.	Dimensions in mm								Mass kg <sup>2)</sup>
	4 bar	5 bar	6 bar		A	B	C	D	E	F	G <sup>1)</sup>	H	
Single acting, spring to open according to Fk 74.59													
80	11	20	25	791294-1220	635	390	100	110	200	257	462	40	30
100	-	13	18	-1220	635	390	100	120	222	278	493	40	39
100	21	25	25	-2220	890	540	145	120	242	315	530	63	53
150	9	25	25	-2225	890	540	145	155	270	343	593	63	71
200	-	12	16	-2230	890	540	145	185	310	383	663	63	103
200	17	25	25	-3230	1050	640	200	185	336	436	716	75	123
250	8	23	25	-3235	1050	640	200	185	336	436	820	75	209
300	-	13	18	-3240	1050	640	200	260	420	520	875	75	224
300	10	25	25	791394-4240	1520	965	260	260	448	580	935	100	281

1 Including NAF valve positioner

2 For PN25

The dP mentioned below is valid for MC-pulp.

For other media contact NAF, see also page 4.

# Accessories

NAF's pneumatic actuators, see data sheet Fk74.59 can be equipped with a large number of accessories. The following are included in NAF's standard program and are suitable for direct mounting to NAF pneumatic actuators.

## VALVE POSITIONER

Pneumatic and electro-pneumatic valve positioner, see data sheet Fk41.82.  
Intelligent valve positioner, see data sheet Fk41.85.

## SOLENOID VALVES

See data sheet Fk79.17.

## FILTER REGULATOR

Can be delivered (part no. 79-SMC-AW20K-F02CE-C).

## ELECTRICAL POSITION INDICATION

See data sheet Fk79.10.

## TERMINAL BOX

The actuator can be equipped with a junction box (part No.349 20 930) of cast aluminium containing terminal blocks for connecting the solenoid valve and position sensors.

# Fugitive emissions Approval, EN ISO15848-1

NAF has certified some of our valves with a new stem sealing, according to EN ISO 15848-1 (this new standard will replace the old TA-luft standard). The packing box solution is with a V-ring set. The new packing set is live loaded with spring cups and equipped with an o-ring above the stem packing. Following valves have been certified in the first test.

## CLASSIFICATION ACCORDING TO TEST RESULTS IS

ISO-FE BH - CC1 - SSA0 - t200oC PN25

### CLASSIFICATION CLASSES:

BH Tightness class B, test fluid Helium  
CC1 20000 mechanical cycles, 2 thermal cycles.  
SSA0 Without shaft seal adjustments during test  
T200°C Temperature Class  
PN25 Endurance Class.

### CERTIFIED PRODUCTS

Flanged :  
PN10 DN200 to DN300  
PN16 DN80 to DN300  
ANSI150 3" to 12"  
PN25 DN200 to DN300

Product code: i.g 8780EG-0100-0B

Code: B

Seat sealing: PTFE

Stem sealing: Safeguard

Other material

CG8M code 87E...

CF3M code 87G...

CG3M code 87F...

Duplex EN 1.4470 code 87D...

Titanium code 87T...

Hastelloy C code 87H...

For other sizes and pressure classes contact NAF.

Contact NAF for further information.

# Product Code

Example:

**Code**    89   8    0    E    G - 0100 - 02  
                  1    2    3    4    5        6        7

## 1. Valve type

**87** NAF Setball

## 2. Material<sup>1)</sup>

**8** 1.4408/CF8M

**E** **CG8M**

**S** SMO254

## 3. Pressure class

**3** PN 16 (DN 80–300)

**4** ANSI Class 150 (Size 3"–12")

**5** PN 25 (DN 200–300 (DN 80–150  
Choose PN 40))

**6** PN 40 (DN 80–300)

**7** ANSI Class 300 (Size 3"–12")

## 4. Stem bearing

**E** Body Steam

PTFE lined bearing -

## 5. Body design

**G** Enlarged outlet

## 6. Dimension

EN	ANSI ratings		ANSI ratings	ANSI ratings	
	Inlet flange DN	Outlet flange DN		Inlet flange Size	Outlet flange Size
<b>0080</b>	80	100	<b>0003</b>	3"	4"
<b>0100</b>	100	150	<b>0004</b>	4"	6"
<b>0150</b>	150	200	<b>0006</b>	6"	8"
<b>0200</b>	200	250	<b>0008</b>	8"	10"
<b>0250</b>	250	300	<b>0010</b>	10"	12"
<b>0300</b>	300	350	<b>0012</b>	12"	14"

## 7. Sealing type

	Seat	Seat seal.	Stem seal.	Max. Temp.
<b>0A</b>	Alloy 6	PTFE	Zebra-CL™	250°C
<b>0B</b>	Alloy 6	PTFE	Safeguard	250°C
<b>02</b>	Alloy 6	EPDM	EPDM	150°C

<sup>1)</sup> Other materials see page 7.

<sup>2)</sup> <sup>02</sup> version is not available in material SMO<sup>254</sup>



# ANDRITZ

All data, information, statements, photographs and graphic illustrations in this leaflet are without any obligation and raise no liabilities to or form part of any sales contracts of ANDRITZ AG or any affiliates for equipment and/or systems referred to herein. © ANDRITZ AG 2024. All rights reserved. No part of this copyrighted work may be reproduced, modified or distributed in any form or by any means, or stored in any database or retrieval system, without the prior written permission of ANDRITZ AG or its affiliates. Any such unauthorized use for any purpose is a violation of the relevant copyright laws. ANDRITZ AG, Stattegger Strasse 18, 8045 Graz, Austria. NAF ProCap Capping Valve Technical bulletin EN 1.0/2024.



JOHANNESBURG  
Tel: 011 397 2833

DURBAN  
Tel: 031 579 2593

**South Africa:**  
**0861 103 103**

E-mail: [sales@valve.co.za](mailto:sales@valve.co.za)  
[www.valve.co.za](http://www.valve.co.za)

