

Maintenance instruction for the WB valves

This instruction is a step-by-step instruction for maintenance on Stafsjö's knife gate valves WB, WB 11, WB12 and WB14.

Following procedures are described in this service instruction:

- A. Disassemble parts of the valve.
- B. Changing box packing, sealing profile and gate.
- C. Torque for gland nuts.
- D. Installation of stem and stem nut on hand wheel operated valves.
- E. Installation of hand wheel and double acting pneumatic cylinder.

For information on installation procedures and other technical documents, please see documents available on www.stafsjo.com.

Stafsjö does not accept any responsibility for the product if maintenance on the knife gate valve is not performed according to this instruction. Neither does Stafsjö accept any responsibility for the product if it has been modified from its original condition.



Spare parts

Spare parts may differ depending on valve size and date of manufacturing. Each knife gate valve is identified with a label containing the article number and serial number. When corresponding with Stafsjö or your local representative, please have these numbers available. Stafsjö recommends the customer to keep one set of spare parts on stock parts for each valve type and size.

Spare parts can be ordered from Stafsjö or your local representative. Stafsjö also offers maintenance service of the valve, either on site at the customer's plant or at Stafsjö's workshop. Please contact Stafsjö or your local representative for further information.

Safety warnings at maintenance

	<ul style="list-style-type: none"> • Steps and procedures described in this maintenance instruction are based on a valve which is <u>not</u> installed in a pipe system. • Before any maintenance begins the valve must be removed from the pipe system and the pneumatic cylinder must be disconnected from the air supply. Follow procedure described in installation and service instruction for the knife gate valve and its actuator. • Maintenance shall be performed by qualified personal. Qualified are those persons who, due to experience, can judge the risk and execute the work correctly and who are able to detect and to eliminate possible risks.
---	---

Figure 1: Main components

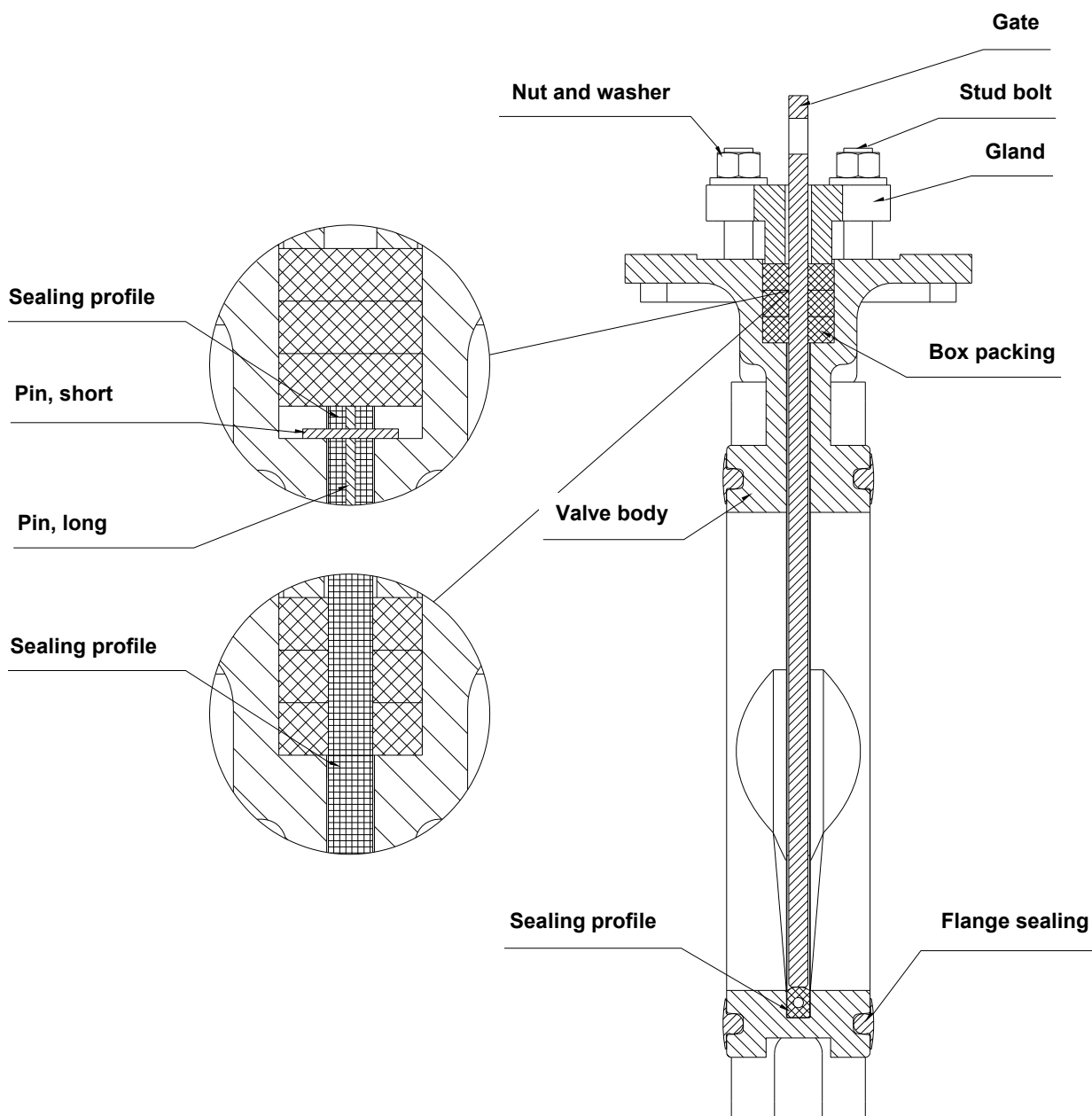
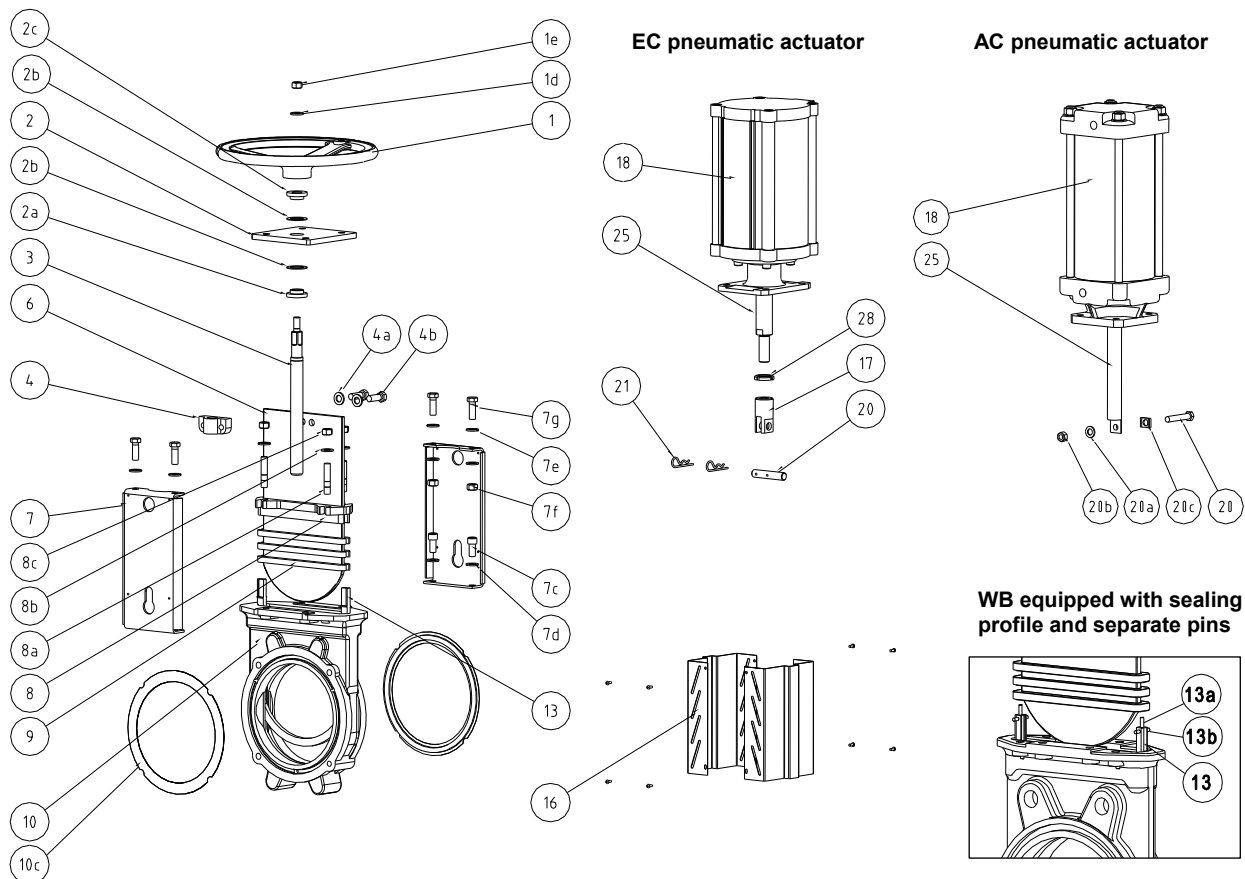

Figure 2: part list

WB 11, WB14, WB 11k and WB 12 equipped with one piece molded sealing profile (U-shaped)



Pos	Part
1	Hand Wheel
1d	Washer
1e	Nut
2	Yoke
2a	Bearing
2b	Slide Washer
2c	Bearing
3	Stem
4	Stem Nut
4a	Washer
4b	Bolt
6	Gate
7	Beam
7c	Bolt
7d	Washer
7e	Washer
7f	Nut
7g	Bolt
8	Gland

Pos	Part
8a	Pinn bolt
8b	Washer
8c	Nut
9*	Boxpacking with a box bottom scraper \geq DN 200
10	Valve body
10c*	Flange sealing
13*	Sealing profile
13a*	Pin, long
13b*	Pin, short
16	Gate guard, not for HW
18	Cylinder
20	Bolt/Clevis pin
21	Locking pins
20a	Washer
20b	Nut
25	Piston rod
28	Locking nut
* Recommended spare parts.	

A. Disassemble parts of the valve

To simplify the disassembling of the knife gate, place the valve upright in a screw vice. Large valves shall be placed on a horizontal work bench. See figure 1 and 2 for identification of the parts in the WB knife gate valve.

1. Open the valve completely.
2. Disassemble the actuator and top.

Hand wheel (1)

- a. Demount the hand wheel (1).
- b. Loosen the bolts (7g), washers (7e) and nuts (7f).
- c. Lift off the bearing (2c), bearing washer (2b), yoke (2), bearing washer (2b) and bearing (2a) from the stem (3).
- d. Loosen the bolts (7c) and washers (7d) and demount the beams (7).
- e. Loosen the bolt (4b), washer (4a) from the stem nut (4) and gate (6).
- f. Remove the stem (3) and stem nut (4).

AC pneumatic cylinder (18)

- a. Loosen the gate guards (16).
- b. Loosen the nut (20b), washer (20a) and bolt (20).
- c. Keep the cylinder (18) in place and loosen the nuts (7f), bolt (7g) and washer (7e).
- d. Remove the cylinder (18).

EC pneumatic cylinder (18)

- a. Loosen the gate guards (16).
 - b. Loosen the locking pins (21) and clevis pin (20).
 - c. Keep the cylinder (18) in place and loosen the nuts (7f), bolt (7g) and washer (7e).
 - d. Remove the cylinder (18).
3. Loosen all the nuts (8c) on the gland (8).
 4. Lift of the gland (8) from the stud bolts (8a).
 5. Remove the box packing braids (9). If the valve with a box bottom scraper, remove that one as well.
 6. Clean the box from residues.
 7. Remove the gate (6). Inspect it and change it if it has dents and scrapes, which will affect and wear out the box packing (9) and the sealing profile (13).
 8. Remove the sealing profile (13).
 9. Clean the sealing profile groove from residues.



The box packing and sealing profile are often damaged when they are removed from the valve body. Stafsjö recommends to change box packing and sealing profile if they have been removed from the valve body.

B. Changing box packing, sealing profile and gate



WB has been available with different types of sealing profiles and box packings. To verify you have correct spare parts, use the valve's article number and serial number in correspondence with Stafsjö or your local representative.

Maintenance instruction WB

Before assembling make sure you have:

For WB equipped with sealing profile and separate pins

- Sealing profile (13) which consists of a rubber profile, one long pin (13a) and two short pins (13b). Put the long pin into the sealing and make sure it is centred. The short wires prevent the sealing profile from being pushed into the valve body by the gate (6).
- Glue of Loctite 480 type. This is a quick-cure type of glue, means that you have short time before it cure.
- Box packing (9), i.e. three pieces of braids.

Sealing profile (13)

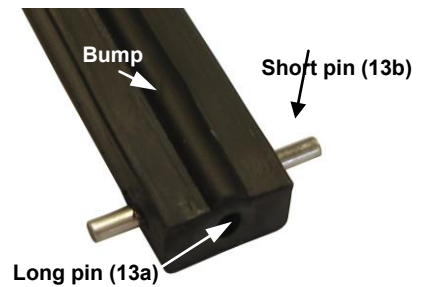

For WB 11, WB14 and WB 12 equipped with one piece moulded sealing profile (U-shaped)

- One piece moulded sealing profile (U-shaped) (13).
- Box packing (9), i.e. 6 pieces of braids. If it is supplied with a box bottom scraper, have that also available.

Additional equipment for both types

- Synthetic lubricator (Multipurpose Grease OKS 1110 or similar grease approved for EPDM and Nitril)
- A plastic surfaced hammer and/or a pneumatic cylinder to push down the gate in closed position.
- Necessary lifting equipment for valves \geq DN 300.



Before assembling starts, check the gate (6) for damages such as dents and scrapes. If the gate is damaged it can wear out the box packing (9), the sealing profile (13) and leakage can occur because of this. To ensure optimal operation, Stafsjö recommends changing the gate if it is damaged.

Follow steps below to change box packing, sealing profile and gate:

1. Make sure that the valve body's gate groove is cleaned and free from grease and residues.
2. Put the valve in a vertically up-right position in a screw vice. If the valve is supplied with a sealing profile and separate pins, then use the gate as a forming tool for the sealing profile.
3. Put grease on the short end of the gate (6)
- 3a. **For WB equipped with sealing profile and separate pins only:**
Take the complete sealing profile (13) and add glue in a zigzag way on the "backside" (opposite side to the bump). **After glued the sealing you have approximately 40 seconds until the glue starts to cure. The time for curing speeds up when the seal is mounted in the valve body. Be quick.**
4. Take the sealing profile and put it into the valve's gate groove from the top of the valve. Make sure it is even above the stuffing box bottom on both sides in the valve.
- 4a. **For WB equipped with sealing profile and separate pins only:**
The bump of the sealing profile must be centered and it shall face the gate (6).
5. Push down the gate (6) to the bottom (100% closed position) of the valve body (10) by using your own weight or use a plastic surfaced hammer. From DN 300 you might have to be two persons to do this or use a pneumatic cylinder to push down the gate. Check that the gate (6) is centered in the valve body (10) according to the sealing profile (13), see picture to the right.
6. Let the gate stay in closed position for approximately 4 min.
7. Add box packing braids.
- 7a. **For WB equipped with sealing profile and separate pins:**
If the valve shall be equipped with a box bottom scraper, add this first in the box bottom and then add three layers of box packing braids on top of this (9).
Make sure that each layers' braid ends is placed on the opposite long side of the previous layer. Use a blunt tool in plastic or wood and a hammer to push the braid into the box.
- 7b. **For WB 11, WB14 and WB 12 equipped with one piece molded sealing profile (U-shaped):**

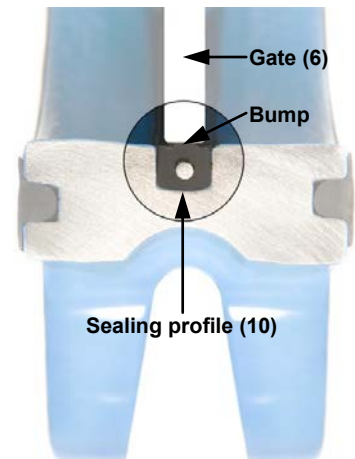

Maintenance instruction WB

- If the valve shall be equipped with a box bottom scraper, add these first in the box bottom and then add three layers of braids on each side of the gate (totally 6 pcs. of braids). To make sure the valve keeps tight during operation, make sure the braid ends reaches each stuffing box corner.
8. Install the gland (8), washers (8b) and nuts (8c). Tighten the nuts gradually and crosswise (see section C) and make sure that the gland is centered in the box and has an equal distance from the gate all around. **Use locking nuts.** Check that there is no metal contact between the gland (8) and the gate (6).



The box packing may start to leak when the system is pressurised and the temperature increases. This is caused by the box packing which is a soft material that moves depending on pressure and temperature and when the valve is operated. If the box packing leaks, retighten the gland nuts (8c) gradually and crosswise according to section 3.3.

C. Torque for gland nuts

The torque T_G in the table below is a recommended value for tightening the gland nuts (8c) when a new box packing has been installed and during operation if the gland box is leaking. Each nut shall be tightened gradually and crosswise until the leakage stops, see figure and table below. Check that there is no metal contact between the gland (8) and the gate (6).

Recommended maximum torque		
DN	Nm	lbf x ft
50-80	20	15
100-150	25	18
200-300	30	22
350-	35	26

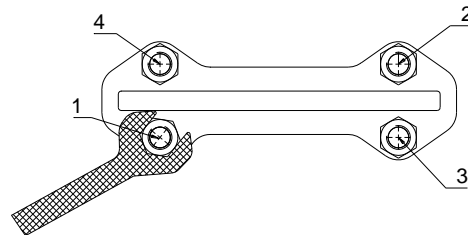

If the gland nuts are tightened to hard, it shortens the lifetime of the box packing and the force needed to operate the valve will increase.

D. Installation of stem and stem nut on hand wheel operated valves

1. Lubricate the thread on the stem (3) with grease and screw on the stem nut (4).
2. Mount the stem nut (4) with the stem (3) on the gate (6) with the washers (4a) and screws (4b).
3. Install hand wheel actuator according to section E.



Do not tighten the screws too hard, since they shall be fully tightened after the complete hand wheel is assembled

E. Installation of hand wheel and double-acting pneumatic cylinder

1. Mount the beam (7) on the top of the valve body (10) with the bolts (7c) and the washers (7d). The holes are placed on different distances from the short side of the beam. The side of the beam with the longest distance between the hole and the short side shall be placed against the top of the valve body (10).
2. Install the actuator.

Hand wheel

- a. Mount the lower bearing (2a) and the bearing washer (2b) on the stem (3).
- b. Mount the yoke (2) on the beams (7). Centre the stem (3) with the lower bearing (2a) and attach the yoke by slightly tighten the bolts (7g), nuts (7f) and washers (7e).
- c. Rotate the stem (3) and make sure the lower bearing (2a) connects to the yoke (2).
- d. Mount the top bearing washer (2b) and bearing (2c) on the stem (3).
- e. Carefully tighten the bolts (4b) on the stem nut (4).

Maintenance instruction WB

- f. Tighten the bolts (7g), nuts (7f) and washers (7e) on the yoke.
- g. Attach the hand wheel (1) and lock it with washer (1d) and nut (e)

Pneumatic cylinder AC

- a. Mount the pneumatic cylinder on the beams (7) and attach it by slightly tighten the bolts (7g), nuts (7f) and washers (7e).
- b. Attach the piston rod (25) to the gate with bolt (20), washer (20a) and nut (20b).
- c. Tighten the bolts (7g), nuts (7f) and washers (7e).
- d. Open the valve completely by gently operating the pneumatic cylinder (18). In this position, the bolts (4b) should be in the centre of the upper hole in the beam (7).
- e. Install the gate guards (16).
- f. Install black caps in the holes of the beam if limit switches is not used.

Pneumatic cylinder EC

- a. Mount the pneumatic cylinder on the beams (7) and attach it by slightly tighten the bolts (7g), nuts (7f) and washers (7e).
- b. Attach the gate clevis (17) to the gate with the clevis pin (20) and the split pins (21).
- c. Tighten the bolts (7g), nuts (7f) and washers (7e).
- d. Open the valve completely by gently operating the pneumatic cylinder (18). In this position, the clevis pin (20) should be in the centre of the upper hole in the beam (7). If it is not, close the valve, demount the split pins (21) and clevis pin (20) and adjust the gate clevis (17) on the piston rod (25) until the clevis pin (20) is in the centre of the upper hole in the beam when the valve is open.
- e. When the gate clevis is in correct position, lock the gate clevis (17) with the locking nut (28).
- f. Install the gate guards (16).
- g. Install black caps in the holes of the beam if limit switches are not used.

- 3. Test the function of the knife gate valve.
- 4. Install the knife gate valve in the system according to Stafsjö's installation and service instructions.
- 5. Operate the valve a few times before the system is pressurized.



Danger

*A knife gate valve with cylinder shall be operated only if all gate guards are installed correctly. **The user's life and health is at stake if this is not followed.** All other handling is the responsibility of the user.*

