

Contents

SAFETY

General

Lifting

Receiving inspection

Installation

Flange gaskets

Starting up

List of materials and spare parts

Ordering of spare parts

Maintenance

To remove the valve from the pipework

To change an Inconel seat ring

To replace EPDM, FPM and PTFE seat rings

To replace PTFE seat rings

To adjust a new seat ring in a valve with manual operating lever or worm gear unit

To adjust the seat ring in a valve with pneumatic actuator

To change the upper shaft seal of O-ring type

To inspect and replace the upper shaft seal of graphite type

To change the packing, item no. 9

To replace the shafts and valve disc

Fitting the actuator to the valve



SAFETY

- Assess all the risks to eliminate the risk of personal injury and material damage. Read these instructions thoroughly!
- Always use the necessary protective equipment and comply with applicable safety directives when working with hazardous or hot/cold medium.
- Never operate a valve without first ensuring that there is no risk of crush injuries. The risk is highest with automatic valves.
- Take necessary safety precautions to prevent unintentional manoeuvre - i.e to atmosphere.
- Never dismantle a valve or part of a valve without ensuring that the line is free of pressure and any content.
- Always check that the valve type and material is suitable for its intended use. This applies especially to highly oxidising and corrosive medium. Observe also the risk of erosion and explosion as well as decaying medium. If in doubt, always request a written recommendation from NAF AB.

1. General

The instructions and list of spare parts in the succeeding apply to NAF-Torex butterfly valves in accordance with catalogue sheet Fk 41.42GB.



The product codes of NAF-Torex valves are as follows:

238ZBB - XXXX - 05	238Z BB - XXXX - 06
238ZBB - XXXX - 07	238Z BB - XXXX - 17
238Z BB - XXXX - 55	238Z BB - XXXX - 66
238Z BB - XXXX - 85	238Z BB - XXXX - 86
238Z BB - XXXX - 88	

¹⁾ Z = Pressure class

²⁾ XXXX = Size

³⁾ 05 — 88 = Sealing type

2. Lifting

All lifting must be carried out on the valve itself and not on the actuator.

3. Receiving inspection

All valves leaving our works are inspected and tested in accordance with the relevant requirements or in accordance with the special provisions specified by the purchaser.

Valves equipped with actuators are subjected to functional testing and are adjusted in such a manner that every unit is completely ready for direct installation in the pipework.

However, in view of damage that may have occurred during transport, it is advisable that receiving inspection be carried out as follows

- Check that **the valve delivered is correct** in terms of type, size, equipment, etc.
- Examine the valve, actuator and valve positioner **regarding possible damages.**
- Operate the valve to the limits of its travel to **check the settings of the limit stops.**

NAF Control Valves

4. Installation

Before installing the valve, **ensure that the pipework is free from impurities**, that the pipe ends between which the valve is to be installed are parallel and are correctly aligned, and that the distance between the pipe ends corresponds to the valve length, including gaskets.

The valve must not be used for drawing together or aligning incorrectly run pipes (see Fig. 2).

Fig.2.

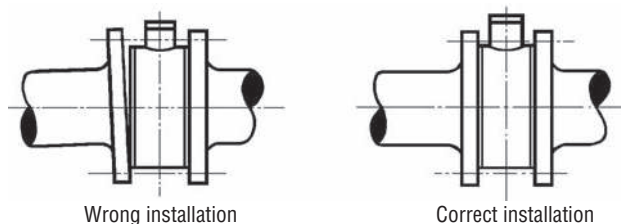

Ensure that the pipe ends align and have the correct distance

NAF-Torex valves can be installed in any position, regardless of the direction of flow. However, we recommend that, if installed in a horizontal run of pipe, the valve should be mounted with the shafts horizontal, in order to prevent the accumulation of dirt and other impurities around the shaft ends.

The butterfly valve body is marked with an arrow which indicates that best tightness thereby that the differential pressure gives an additional torque in the closing direction while a differential pressure towards the plane side gives an extra torque in the opening direction.

Locate the valve so that it will be **easily accessible for inspection and service**, particularly if the valve is equipped with an actuator and a valve positioner.

Ensure that the valve is installed so that the connected pipe ends do not obstruct the **free movement of the disc** when the valve is operated.

The pipes should be supported on each side of the butterfly valve, in order to relieve the valve of loads and avoid vibrations.

5. Flange gasket

Gaskets to the dimensions specified in SS 359, DIN 2690 or ANSI B 16.5, 1988, Table E1, Figure E2, Class 150 can be used.

6. Starting up

Before starting up, flush the pipework - with all valves in the open position - so that any impurities that may damage the sealing surfaces of the valve and impede its operation will be flushed away.

For other information concerning starting up, see "Instructions for valve positioners" Fi 41.82A.

7. List of materials and spare parts

Item	Qty	Part	Material	Sealtype
1	1	Body	EN 1.4408/CF8M	
2	1	Disc	EN 1.4408/CF8M	
3	1	Gland cover	EN 1.4408/CF8M	
4	1	Stem, upper	EN 1.4460	
5	1	Stem, lower	EN 1.4460	
6	1	Clamp ring	DN >250 EN1.4408/CF8M DN ≤250 EN1.4436/ AISI316	
7	1	Retaining	EN1.4436	
8*	1	Gasket	Graphite	
9*	1	Gasket	Graphite	
10*	1	Seat ring	Inconel 718	05-07,17
11*	1	Seat ring	EPDM	66
12*	1	Seat ring	FPM	55
14*	1	Seat ring	PTFE carbon reinforced	85,86,8A,8B
15* ¹⁾	1	Clamp ring	DN >250 EN1.4408/CF8M DN ≤250 EN1.4436/ AISI316	
16*	1	O-ring	EPDM	06,66,86
17*	1	O-ring	EPDM	06,66,86
18*	1	O-ring	FPM	05,55,85
19*	1	O-ring	FPM	05,55,85
20*	1	Backing ring	PTFE	
21*	1	Boxpacking	Graphite	07,17
22	1	Cup spring	EN1.4310	0B, 8B
23	1	Gland cover	EN 1.4408/CF8M	
24A	1	Boxpacking Zebra-CL™	V-ring PTFE	0A, 8A
24B	1	Boxpacking Safeguard	V-ring PTFE liveloaded	0B,8B
26	1	Stem bearing	Metaloplast	
27	1	Stem bearing	Metaloplast	
28	2	Screw	A4	
29	2	Nut	A4	
30	2	Screw	A4	
31	²⁾	Screw	A4	
37	1	Washer	Metaloplast	

1) Clamp ring item15 must be included if the valve is to be converted from some other type of seat to a PTFE seat ring.

2) Quantity depending on dimension.

*) Recommended spare parts.

Other material combinations are available to order - consult your NAF representative.

NAF Control Valves

Fig 3. NAF-Torex - spareparts, shaft sealing and seating types

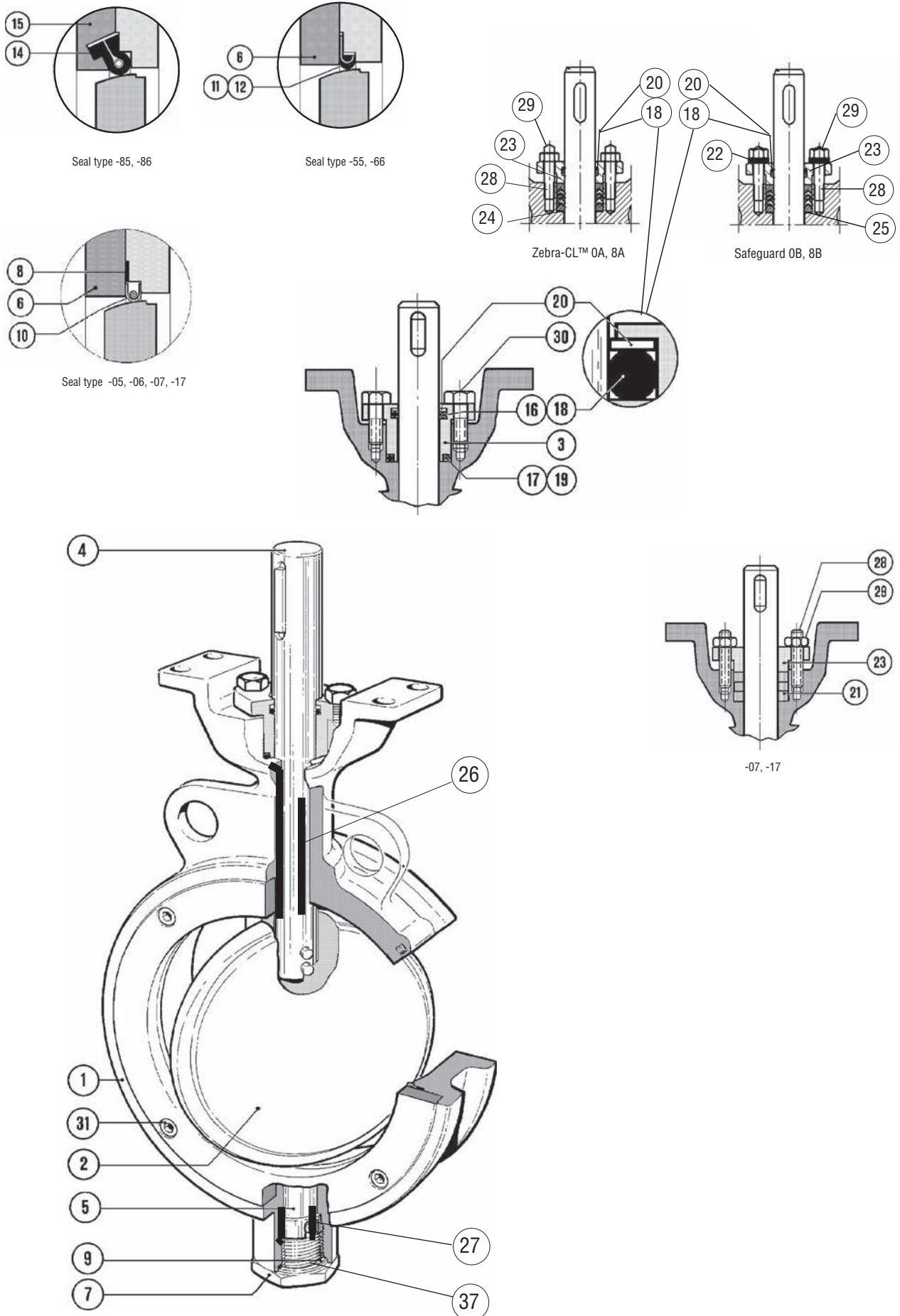

NAF Control Valves

8. Spare parts

State the following data when ordering spare parts:

1. Product code of the valve - incl. DN according to Fk 41.42 and the Manuf. No. specified on the identification plate of the valve.
2. Description of the part, its item No and quantity required. See table section 7.

Ordering example: 2382BB-0200-05,
manuf. No 1234567,
Seating item 10.
Quantity 1 st.

9. Maintenance

If the valve disc or seat ring has sustained damage due to impurities in the pipework or for some other reason, or if the seat ring and shaft seals need replacing after a long period of service, the valve must be overhauled.

Many valves are installed in such locations that their performance is of decisive importance to the entire process. Such valves should be inspected regularly and any faults should immediately be corrected.

9.1 To remove the valve from the pipework

The procedure for inspection and maintenance, for which no special tools are necessary, is as follows:

Ensure that the valve is not under pressure.

1. Ensure that the recommended spare parts and also the gaskets for the pipe flanges are available.
2. Close the valve.
3. Shut off all compressed air connections and isolate all electrical connections to the actuator.
4. Disconnect all compressed air lines and electric cables connected to the actuator.
5. Note the direction of flow which is shown by an arrow on the valve body.
6. Release the flanged joint between the valve and the pipework. Then lift out the valve. **Apply all lifting forces to the valve itself and not to the actuator.**

9.2 To change an Inconel seat ring

If an actuator is fitted to the valve, it need not be removed for inspection and replacement of the seat ring.

1. Set the valve to the fully open position.

2. Remove the bolts, retainer ring (6), gasket (8) and seat ring (10). Use the two tapped holes (M6) in the retainer ring to remove the ring from the valve body.
3. Carefully wash all parts. First use warm water and then, if necessary, a suitable solvent. Do not scrape any of the machined surface with hard tools.
4. Examine the surfaces on the periphery of the valve disc. Minor scratches and marks on the sealing surface can be rubbed down with emery paper.
5. Inspect the seat ring. During such overhauls, it is always advisable to fit a new seat ring.
6. Refit the gasket (8).
7. Spray the valve disc, sealing surface and seat ring with a suitable lubricant, such as Molykote 321 R or Gleitmo 900 or Unimoly C 220. Allow the lubricant to dry for at least 15 minutes.
8. Fit the seat ring (10) and retainer ring (6) into the valve body.
9. Screw in the retainer ring bolts, but don't tighten the retainer ring.
10. Check that the A-measure is correct according to 9.5.

9.3 To replace EPDM and FPM seat rings.

- 1-4 See the corresponding items in section 9.2.
5. Carefully clean the groove in the body into which the seat ring is mounted.
6. Turn the valve disc almost to the closed position (about 2° from the closed position) and lock it in this position.
7. Spray the seat ring with a PTFE lubricant, such as Fluor Carbon 1094, and fit the ring into its seat in the body. Fit the retainer ring (6) over the seat ring and clamp it in position with its bolts. Tighten one pair of diagonally opposite bolts, then a pair of diagonally opposite bolts at right angles to the first pair, and so on until the retainer ring is firmly in position. Set the position of the valve disc in accordance with the stamped dimension A as shown in Fig. 4.

NAF Control Valves

9.4 To replace PTFE seat rings.

- 1-4 See the corresponding items in section 9.2.
5. Carefully clean the groove in the body into which the seat ring is mounted.
6. Make sure that the PTFE seat ring is mounted with its L - shaped (or the sharp corner) side towards the retainer ring.
7. The disc must be turned 180° before the retainer ring is placed in the valve. When the seatring is correctly positioned into the retainer ring, place the package in the valve.
8. Carefully fasten the retainer ring, but do not tighten it.
9. Close the disc for centering the seatring, screw down the retainer ring to keep the seatring in place.
10. Check that the seatring is centered. The play shall be evenly applied between the disc and the body.
Start to fasten the retainer ring by crosswisely changing screws with evenly applied force.
11. The retainer ring shall more or less flush with the valve body. If not, gently hammer with a plastic hammer at the same time as the screws are tightened.
12. Now you can mount the actuator and adjust the end positions of the actuator until you get the correct A-measure. This is described separately below.

The valves seat ring should now be correctly prepared and should not leak. Please note that PTFE can leak before it becomes warm and adjusts to the disc. This is however a small leakage and should not be considered. The valve will be tight shortly.

9.5 To adjust a new seat ring in a valve with manual operating lever or worm gear unit

1. Close the valve to the sealing position corresponding to the value of dimension "A" shown in Fig. 4.
2. Adjust the end stop of the operating lever or the worm gear unit so that the sealing position will not be exceeded.
3. Tighten the retainer ring bolts in diagonally opposite pairs.

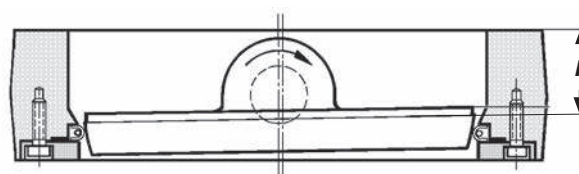

Fig. 4. Adjusting a new seat ring.

9.6 To adjust the seat ring in a valve with pneumatic actuator

1. Turn the valve to closed position, although without applying a sealing torque. The valve disc should then only just be in contact with the seat ring in the valve body.
2. Adjust the end position stop to the position in which the valve is almost closed.
3. Connect the compressed air supply to the actuator. If the end position stop is correctly set, the valve disc will not move.
4. Adjust the end position stop until the actuator has turned the valve disc to the sealing position, i.e. dimension "A" shown on the valve in accordance with section 9.4 and Fig. 4.
5. Lock the end position stop so that the sealing position will not be exceeded.
6. Tighten the retainer ring bolts.

9.7 To change the upper shaft seal of O-ring type

If the shaft seal is leaking, change the upper O-ring (16 and 18). The valve need not be removed from the pipework for this work.

Make sure that the valve is not under pressure.

1. If an actuator is fitted to the valve, remove it. Begin by removing the valve positioner. This can easily be done after the plastic cover of the valve positioner has been removed. Remove the four bolts securing the valve positioner to the actuator. Then remove the nuts securing the actuator to the valve mounting plate and dismantle the actuator.
2. Remove the keys.
3. Remove the bolts securing the cover (3) and remove the cover. Then remove the O-rings.
4. Clean the surfaces of the shaft, cover and the recess in the valve body.

NAF Control Valves

- Carefully examine the shaft surface to make sure that it is completely free from scratches. Remove any burrs from the keyways.
- Fit two new O-rings (16 and 18) and (17 and 19) and a new backing ring (20). Lubricate the O-rings with Silicone grease.
- Fit the cover (3), and spray locking compound, such as Loctite 641, onto the bolt threads and the tapped holes in the valve body. Tighten the bolts.

9.8 To inspect and replace the upper shaft seal of graphite type

The stuffing box usually requires inspection and adjustment after the valve has been taken into service. After a certain period of time in service, it may sometimes also be necessary to repack the valve.

Ensure that the valve is not under pressure.

- Remove the actuator as described in section 9.7.
- Remove the nuts (29) and remove the gland bush (23) and the packing (21 - 22).
- Clean the surfaces of the shaft, gland bush (23) and recess in the valve body.
- Carefully examine the surface of the shaft which must be completely free from marks and scratches.
- Fit new packing (21 - 22). Then fit the gland bush (23) and the nuts (29).
- Tighten the nuts (29) sufficiently to ensure that the packing is correctly seated and that it is in contact with both the shaft and the valve body.

Note: Check the condition of the packing and, after the valve has been taken into service, retighten the nuts (29), if necessary.

9.9 To change the packing, item no. 9

Ensure that the valve is not under pressure.

- Remove the set screw (7) and gasket (9).
- Carefully clean the set screw (7) and the lower, loadcarrying part of the shaft (5).
- Fit a new gasket (9).
- Spray locking compound, such as Loctite 641, onto the screw threads in the valve body.
- Fit and tighten the set screw (7).

10. To replace the shafts and the valve disc

If the valve disc (2) or shafts (4) and (5) have been damaged and need replacing, the valve must be sent to NAF for repair, since special tools and fixtures are necessary for correct assembly.

11. Fitting the actuator to the valve

- The actuator can be mounted directly on the valve. The mounting flange and the shaft of the valve follow the NAF standard for securing the actuator.
- Turn the valve to the closed position (clockwise), although without applying a closing torque. (The valve disc should then only just be in contact with the seal ring in the valve body.)
- Fit the actuator. The actuator should be in the **"almost closed"** position, i.e. 5 - 8° of the rotary travel of the actuator should remain before the end position. Adjust the end position stop of the actuator to **this almost closed position**.
- Connect the compressed air supply to the actuator. (Applies to pneumatic actuators.)

NAF Control Valves

5. Adjust the end position stop until the actuator has turned the valve disc to the sealing position. This sealing position varies from valve to valve, and the dimension is specified on the valve body adjacent to the arrow showing the direction of flow. See dimension "A" in Fig. 4 in section 9.4.
6. **General**
The actuator may be fitted either in line with the connected pipes or transversely to them. An intermediate plate is necessary for mounting the actuator in line with the pipework.

N.B. The direction of closure must always be clockwise, as viewed from the actuator.

Before fitting the actuator, it is important to ensure that the actuator fits the shaft. First try without keys, to check that the drive slips easily onto the shaft. Also check that the keys are easy to fit and match the keyways in the shaft. Grease the actuator shaft entry.

Take care to ensure that the end position stops on the actuator are correctly set and locked. If the end position stop for the closed position is incorrectly set, the valve disc may overtravel, which could damage the sealing elements.

NAF Control Valves



JOHANNESBURG
Tel: 011 397 2833

DURBAN
Tel: 031 579 2593

South Africa:
0861 103 103

E-mail: sales@valve.co.za
www.valve.co.za



SCAN ME