



AUTOMATION AND DIGITALIZATION

NAF SETBALL BALL SECTOR VALVES

TECHNICAL BULLETIN



ANDRITZ

ENGINEERED SUCCESS

Primary characteristics

The NAF Setball valve from Flowserve is a highly versatile and cost-effective solution designed to deliver unmatched performance in a range of general service and erosive applications, such as fibers and slurries.

The Setball valve is a V-port ball sector valve that combines a compact design with excellent equal percentage flow characteristics and high flow capacity. It is designed primarily for modulating control applications; however, it can also be used effectively for shut-off service.

The NAF Setball valve is engineered to increase process yield and plant uptime through durable functionality and higher reliability. Its features include:

- A ball sector with a **V-port**, resulting in **excellent control characteristics** in combination with high **flow capacity and rangeability**
- A **one-piece, leak-proof** valve body, **flanged or wafer** design, that provides a cost-effective method for minimizing leak paths
- Enhanced product integrity through a **V-ring stem seal packing** and an optional **spring loading** that provides safe operation within a wide temperature coverage
- Dual **low-friction bearings** facilitate **smooth operation** and allow the use of a **small actuator**
- A stem with a **splined transmission** to the ball sector that provides **optimum control performance**
- **Direct-actuator mounting** capabilities of the NAF Turnex™ actuator that provide a high-performance, vibration-resistant, compact valve package
- **Spring-loaded metal seats** with a rigid welded overlay of Alloy 6 that provide higher leakage resistance over extended periods or alternatively, **metal-supported, reinforced PTFE** seats for optimum tightness
- Special **low-flow trims** for the smallest size
- Unique **Z-trim™** option that **minimizes the risks of cavitation and aerodynamic noise**, resulting in a better working environment and lower maintenance costs
- Reduced downtime through an easy-to-service arrangement, which allows for simplified replacement of the seat and seat seal without the need for removing the ball sector and stem

CE-marked according to Pressure Equipment Directive (PED 2014/68/EU) module H, category III.

TECHNICAL SPECIFICATIONS FOR STANDARD DESIGN

Material	Stainless steel, carbon steel or higher alloys
Size range	DN 25 to 700, 1 to 28 in.
Pressure ratings	PN 10 to 40, ANSI Class 150 to 300
Face to Face length	IEC 60534-3-2
Valve design	ANSI B16.34 or EN 12 516
Installation method	Wafer or flange type
Temperature range	-30°C to 250°C (-22°F to 482°F); see graph on pages 8 and 9
Test procedure	According to IEC 60534-4 Hydrostatic test: 1.5 x maximum working pressure Metal seat leakage test: 1.0 x maximum allowed differential pressure tested with water with inhibitor ⁽¹⁾ Soft seat leakage test: 3.5 bar(g) tested with gas
Tightness class ⁽²⁾	Metal seats: IEC 60534-4 Class IV-S1, tested with water ⁽¹⁾ Soft seats: IEC 60534-4 Class VI, tested with gas

⁽¹⁾ Gas test upon request, according to IEC 60534-4 Class IV

⁽²⁾ Tested in preferred flow direction



Applications

The NAF Setball valve can be used in an extensive range of control applications spanning general services to applications with particles, fibers, slurries etc. Due to its excellent rangeability and high flow capability in combination with its overall compact size, it is a viable economical alternative to linear control valves.

The NAF Setball valve is recommended for a variety of applications in the following industries:

- Pulp and paper
- Chemical
- Oil and gas
- Metals and mining
- District heating
- General industries



Figure 1: NAF Setball valve, flanged version

Materials of construction

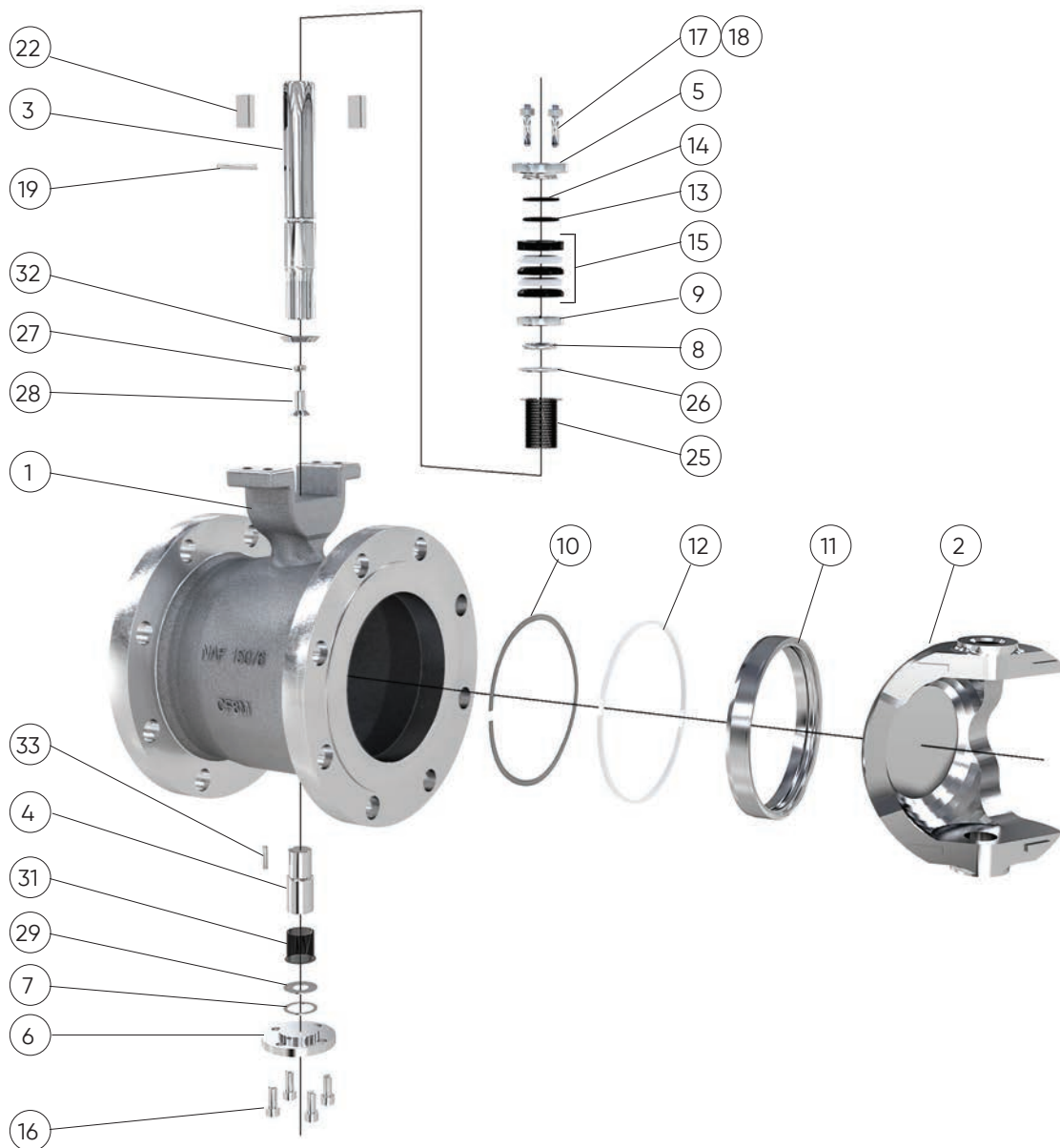

Seats

TABLE 1: MATERIAL (METAL SEATED, STANDARD VERSION)

Item	Qty.	Part	Stainless Steel	Carbon Steel
1	1	Body	CF8M (~EN1.4408)	WCB
2	1	Ball sector	CF8M (~EN1.4408) + hard chrome plated	
3	1	Stem, upper	EN1.4460 (type AISI 329)	
4	1	Stem, lower	EN1.4460 (type AISI 329)	
5	1	Gland	CF8M (~EN1.4408)	
6	1	Bottom cover	AISI 316/EN1.4436	
7	1	Gasket	Graphite	
8	2	Locking segment	AISI 316/EN1.4401	
9	1	Bearing seat	EN1.4460 (type AISI 329)	
10	1	Wave spring	AISI 316/EN1.4436	
11	1	Seat ring	Alloy 6 + stainless steel	
12	1	Seat seal	PTFE + stainless steel	
13	1	O-ring	FPM	
14	1	Backing ring	PTFE	
15	1	Stem packing	R-PTFE/PTFE	
16	4	Screw	A4	
17	2	Screw	A4	
18	2	Nut	A4	
19	1	Pin	EN1.4460 (type AISI 329)	
22	2	Key	A4	
25	1	Bushing, upper	PTFE + stainless steel	
26	1	Washer	AISI 316/EN1.4436	
27	1	Thread insert	A4	
28	1	Screw	A4	
29	1	Bearing washer	PTFE + stainless steel	
31	1	Bushing, lower	PTFE + stainless steel	
32	1	Washer	AISI 316/EN1.4436	
33	1	Pin	EN1.4460 (type AISI 329)	



Seat rings

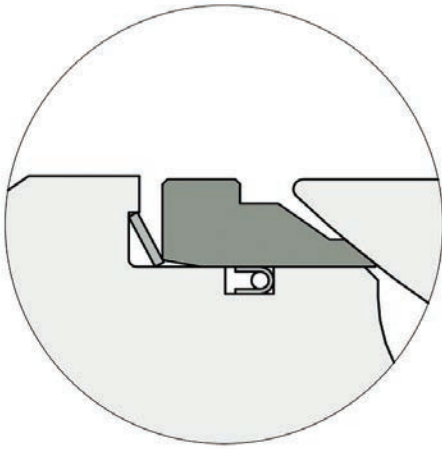

Metal seat (standard)

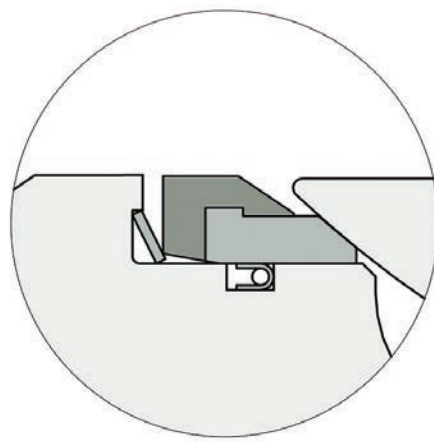

Soft seat (standard)

Ball sectors

- **Standard.** The standard ball sector has a V-port, resulting in excellent control characteristics in combination with high-flow capability and rangeability. When used for pulp applications, it also prevents dewatering of the pulp when controlling small flows.
- **Low-flow** trims are available for the smallest size, DN 25/1 in. These can be used to extend the application coverage into very low flow, like the dosing of additives.
- **Z-trim.** The ball sector with Z-trim is a unique solution where the pressure drop is divided into several steps, resulting in minimized risks for cavitation and aerodynamic noise.



Figure 2: NAF Setball valve, flanged version with Z-trim

OTHER VERSIONS

- **Degreased.** The NAF Setball valve has an option D, which needs to be specified for service in which the valve must be cleaned and degreased. In this version, all components are degreased before assembly and a special grease is used in assembly. The valve is tested with gas, according to IEC 60534-4 Class IV for metal seat and Class VI for soft seat.
Option: D
- **ATEX approved.** When intended for use in an explosive atmosphere, please specify option XA. With this option, the valve is certified according to ATEX 94/9/EC II 2 G/D c.
Option: XA
- **Internally sealed stems.** Internal O-rings for sealing the stems from the medium.
Option: I
- **Fugitive emissions approved.** The Setball valve has been tested and fulfills fugitive emission requirements according to ISO15848-1. The approval is valid for sizes DN 25/1 to DN 300/12 in. with a maximum operating pressure of 25 bar and the spring-loaded V-ring stem packing. The valid classification is ISO-FE BH-CC1-SSA0-t200°C PN25.
Use seal version B (position 8 in the product code).
- **Setball for MC-pulp.** This special version of the NAF Setball valve is specifically developed for use with medium consistency (MC) pulp 8 to 19%. This Setball valve version has an enlarged outlet with one size bigger flange on the outlet to get an excellent flow characteristic for the MC-pulp of the valve.

Please see: Technical Bulletin Fk 41.54

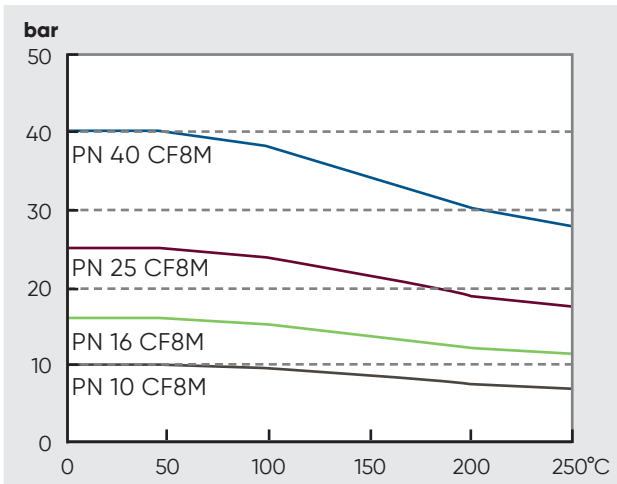

Figure 3: NAF Setball valve for MC-pulp

Working pressure and temperature

MAX. WORKING PRESSURE, PN-RATED VALVES

Stainless steel body (CF8M/1.4408)



Carbon steel body (WCB/1.0619)

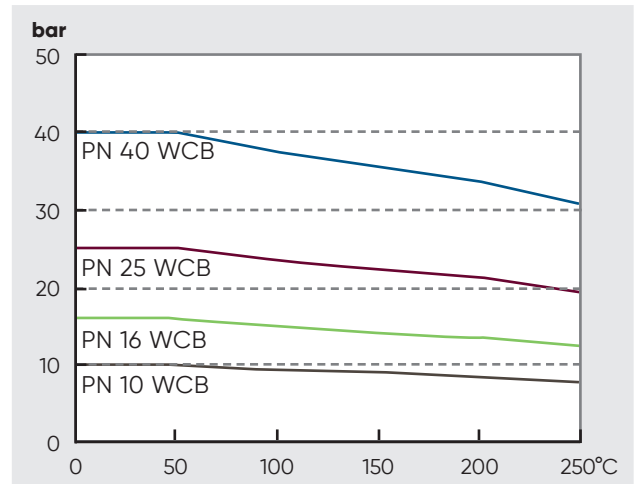

MAX. WORKING PRESSURE, ANSI-RATED VALVES

Stainless steel body (CF8M/1.4408)

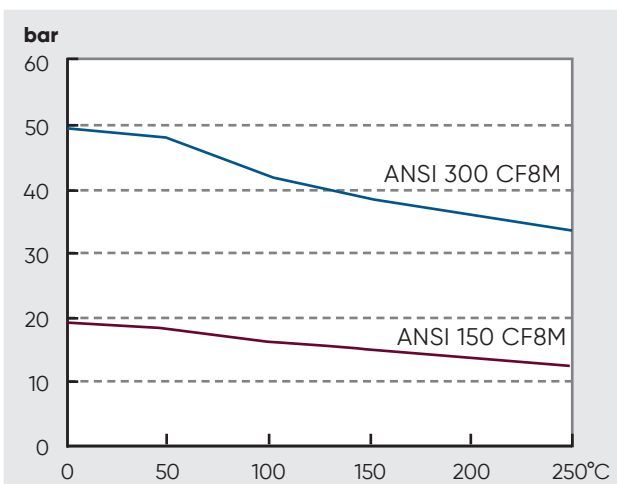

Carbon steel body (WCB/1.0619)

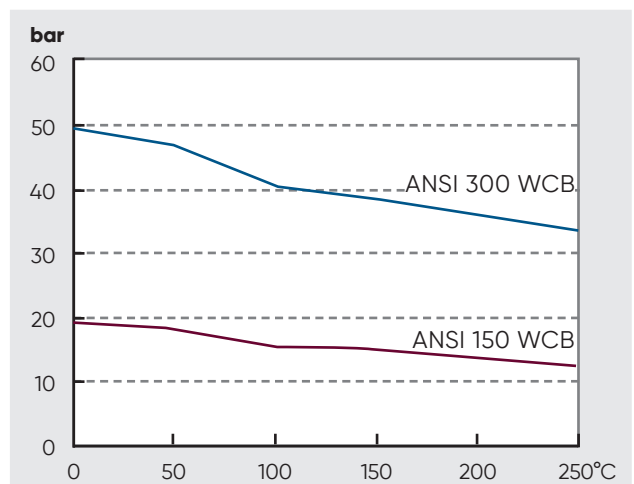

Differential pressure and temperature

MAX. DIFFERENTIAL PRESSURE, ALLOY 6 SEAT, CLOSED VALVE

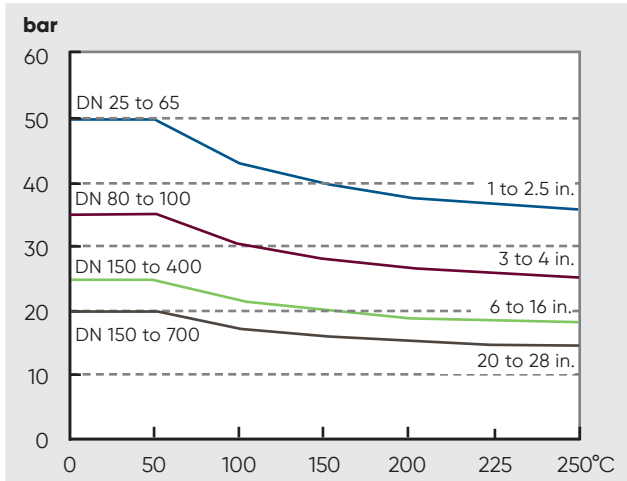

MAX. DIFFERENTIAL PRESSURE, R-PTFE SEAT, CLOSED VALVE

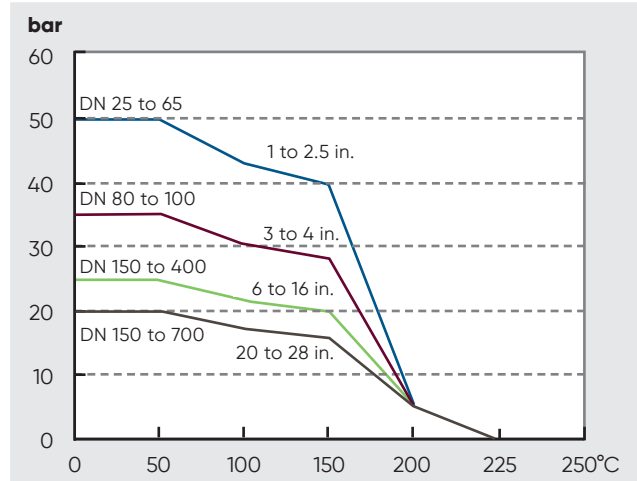

Please note that the maximum allowed differential pressure can be further reduced if the maximum allowed working pressure, based on the body material and pressure class of the valve, is lower than the maximum allowed differential pressure.

MAX. DIFFERENTIAL PRESSURE, IN CONTROL SERVICE

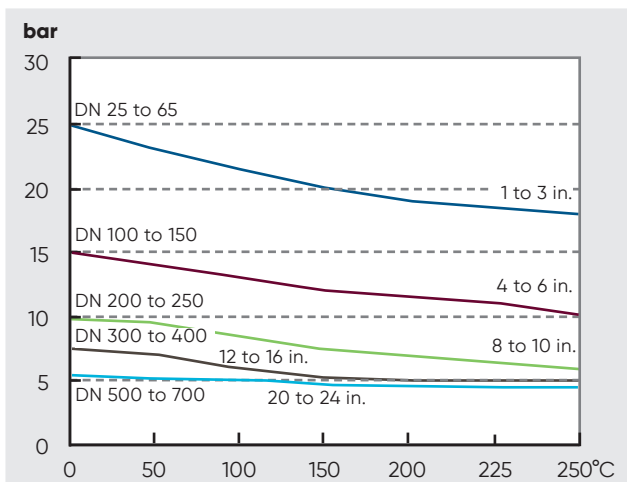

Operating torque and flow capacities

TABLE 2: OPERATING TORQUE, NM

DN	NPS	Differential pressure in bar																	
		3		10		15		20		25		30		35		40		50	
		R-PTFE	Alloy 6	R-PTFE	Alloy 6	R-PTFE	Alloy 6	R-PTFE	Alloy 6	R-PTFE	Alloy 6	R-PTFE	Alloy 6	R-PTFE	Alloy 6	R-PTFE	Alloy 6	R-PTFE	Alloy 6
25	1	5	7	8	12	12	17	15	21	18	25	20	29	23	33	26	37	32	45
40	1.5	6	8	11	15	15	21	19	27	22	32	27	38	31	44	35	50	43	62
50	2	7	10	13	19	18	26	22	31	27	38	31	44	35	50	39	56	48	69
65	2.5	13	19	25	35	32	45	42	60	49	70	57	81	65	93	73	104	89	127
80	3	15	22	32	45	42	60	56	80	67	95	78	112	90	128	-	-	-	-
100	4	21	30	42	60	60	85	77	110	95	135	112	160	130	185	-	-	-	-
150	6	53	75	109	155	147	210	189	270	228	325	-	-	-	-	-	-	-	-
200	8	98	140	214	305	294	420	375	535	455	650	-	-	-	-	-	-	-	-
250	10	175	250	378	540	525	750	665	950	812	1,160	-	-	-	-	-	-	-	-
300	12	301	430	620	885	847	1,210	1,075	1,535	1,309	1,870	-	-	-	-	-	-	-	-
350	14	440	629	928	1,325	1,345	1,921	1,623	2,318	1,971	2,815	-	-	-	-	-	-	-	-
400	16	624	892	1,281	1,830	1,845	2,635	2,220	3,171	2,689	3,841	-	-	-	-	-	-	-	-
500	20	784	1,120	1,512	2,160	2,093	2,990	2,653	3,790	-	-	-	-	-	-	-	-	-	-
600	24	1,582	2,260	3,010	4,300	4,130	5,900	5,250	7,500	-	-	-	-	-	-	-	-	-	-
700	28	2,268	3,240	4,480	6,400	6,160	8,800	7,770	11,100	-	-	-	-	-	-	-	-	-	-

The minimum design differential pressure for selecting the actuator is 3 bar.

The specified torques in the table above are for clean media. For steam and with Alloy 6 seat rings, increase the required torque by a factor of 1.2. If the media is a slurry or contains solids, etc., consult your Flowserve representative.

TABLE 3: FLOW CAPACITIES AND CHARACTERISTICS

DN	NPS	Flow capacities of Kv and Cv at the opening angle of																		Z-trim option at 90° opening angle	
		15°		20°		30°		40°		50°		60°		70°		80°		90°			
		Kv	Cv	Kv	Cv	Kv	Cv	Kv	Cv	Kv	Cv	Kv	Cv	Kv	Cv	Kv	Cv	Kv	Cv	Kv	Cv
25/05	1T05	0.04	0.05	0.09	0.10	0.24	0.28	0.40	0.46	0.56	0.65	0.75	0.87	0.94	1.09	1.19	1.38	1.52	1.76	-	-
25/10	1T10	0.04	0.05	0.10	0.12	0.30	0.35	0.70	0.81	1.20	1.39	1.80	2.09	2.60	3.0	3.5	4.1	5.1	5.9	-	-
25/15	1T15	0.50	0.58	0.70	0.81	1.20	1.39	2.00	2.3	3.3	3.8	4.4	5.1	5.6	6.5	8.3	9.6	11	13	-	-
25/20	1T20	0.20	0.23	0.30	0.35	0.90	1.04	2.3	2.7	4.1	4.8	7.1	8.2	10	12	15	17	22	26	-	-
40	1.5	1.0	1.2	2.1	2.4	5.1	5.9	9.5	11	15	17	23	27	33	38	53	61	65	75	32	37
50	2	1.6	1.9	3.2	3.7	8.2	9.5	15	17	25	29	38	44	53	61	85	99	103	119	49	57
65	2.5	2.4	2.9	4.0	4.6	8.0	9.3	17	20	27	31	44	51	65	75	98	114	145	168	72	84
80	3	4.0	4.6	8.0	9.3	18	21	32	37	52	60	78	90	110	128	150	174	245	284	181	210
100	4	9.0	10	15	17	31	36	53	61	83	96	124	144	180	209	254	295	415	481	372	432
150	6	25	29	40	46	78	90	135	157	212	246	310	360	445	516	615	713	970	1,125	769	892
200	8	30	35	50	58	110	128	200	232	310	360	470	545	670	777	920	1,067	1,250	1,450	1,219	1,414
250	10	33	38	80	93	200	232	337	391	575	667	830	963	1,150	1,334	1,560	1,810	2,480	2,877	2,206	2,559
300	12	87	101	173	201	390	452	655	760	995	1,154	1,410	1,636	1,930	2,239	2,580	2,993	3,960	4,594	3,216	3,731
350	14	126	146	250	290	565	655	945	1,096	1,430	1,659	2,035	2,361	2,780	3,225	3,710	4,304	5,705	6,618	2,782	3,227
400	16	171	198	340	394	765	887	1,285	1,491	1,950	2,262	2,770	3,213	3,785	4,391	5,050	5,858	7,765	9,007	3,715	4,309
500	20	205	238	435	505	990	1,148	1,710	1,984	2,600	3,016	3,690	4,280	5,045	5,852	6,730	7,807	10,350	12,006	6,036	7,002
600	24	271	315	561	650	1,274	1,478	2,087	2,421	3,238	3,756	4,683	5,432	6,704	7,776	9,417	10,924	14,556	16,885	-	-
700	28	389	452	804	933	1,828	2,120	2,993	3,472	4,634	5,375	6,868	7,967	9,448	10,960	12,764	14,806	19,966	23,161	-	-

Dimensions and weight

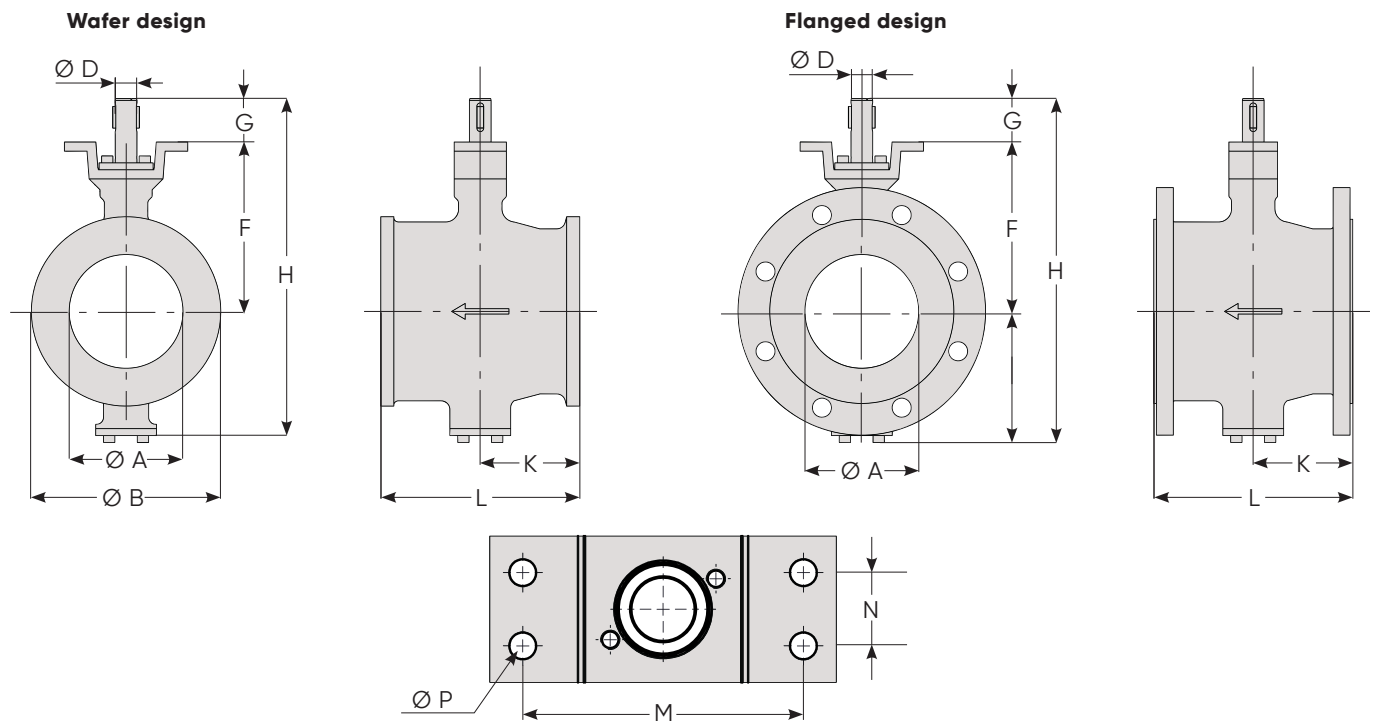

TABLE 4: VALVE DIMENSIONS AND WEIGHT

DN	NPS	Dimensions, mm												Weight, kg	
		A	B	D	E	F	G	H	K	L	M	N	P	Wafer	Flanged ⁽¹⁾
25	1	20	65	20	60	120	43	225	51	102	115	30	11	4	7.2
40	1.5	32	86	20	75	125	43	245	57	114	115	30	11	5.5	9.8
50	2	40	105	20	90	131	43	265	62	124	115	30	11	6.5	13.0
65	2.5	50	122	20	101	139	43	283	68	135	115	30	11	9	15.5
80	3	70	132	20	110	145	43	300	83	165	115	30	11	11.5	18
100	4	85	162	20	120	167	43	332	97	194	115	30	11	15.5	25
150	6	130	218	25	155	195	50	400	115	229	115	30	11	26	41
200	8	170	273	30	185	236	59	480	130	243	160	40	14	42	64
250	10	208	-	35	230	295	65	590	155	297	160	40	14	-	100
300	12	258	-	40	260	320	80	660	183	338	214	60	18	-	145
350	14	282	-	50	290	360	93	742	200	400	214	60	18	-	174
400	16	316	-	50	308	383	93	784	224	400	214	60	18	-	211
500	20	400	-	50	371	460	93	942	288	508	214	60	18	-	348
600	24	498	-	80	509	584	149	1,242	350	610	277	115	33	-	840
700	28	581	-	80	569	685	149	1,403	407	710	277	115	33	-	1,100

⁽¹⁾ Applies to the weight of a PN 10 valve

Actuators

NAF Setball valves are available with hand levers, worm gears, pneumatic actuators, or electrical actuators and accessories.

The maximum differential pressure for selected actuator and valve is based on the torque values in Table 2 and valid for clean media, e.g., water. For steam and other media, please see notes under Table 2.

The NAF Turnex pneumatic actuator can be directly mounted to the NAF Setball valve without any couplings or brackets. Together with the direct-mounting capabilities of all NAF positioners and several of the Flowserve positioners (PMV™ P5/EP5, PMV D3/D20/D30 and Logix™ 520 MD+/Logix 3800), this provides high performance, vibration resistance and a compact valve package suitable for precision control.

Please see data sheet for further information on the NAF Turnex actuator capabilities and all other available accessories.

If other pneumatic or electrical actuators are required, consult your Flowserve representative.

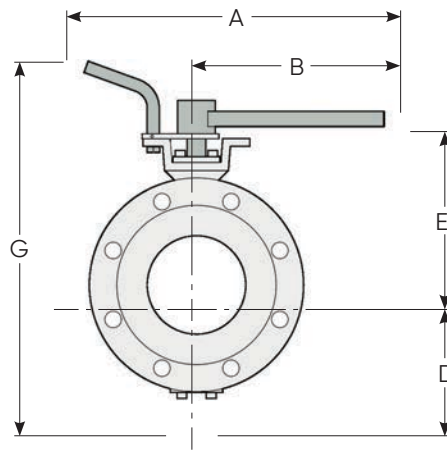

TABLE 5A: NAF SETBALL VALVES WITH HAND LEVERS

DN	NPS	Max. differential pressure, seat of		NAF number	Dimensions, mm					Weight, kg		
		R-PTFE	Alloy 6		A	B	D	E	G	Wafer	Flanged	
Hand lever as per Fk 70.51												
25	1	50	50	791020-2	500	350	60	158	300	6	9.2	
40	1.5	50	50	791020-2	500	350	75	163	320	7.5	11.8	
50	2	50	45	791020-2	500	350	90	168	340	8.5	15	
65	2.5	35	35	791020-2	500	350	101	176	348	11	17.5	
80	3	35	30	791020-2	500	350	110	183	375	13	20	
100	4	25	25	791020-2	500	350	120	205	497	18	27	
150	6	12	8	791020-3	500	350	155	233	470	28	43	
200	8	7	5	791020-4	615	450	185	273	550	45	67	

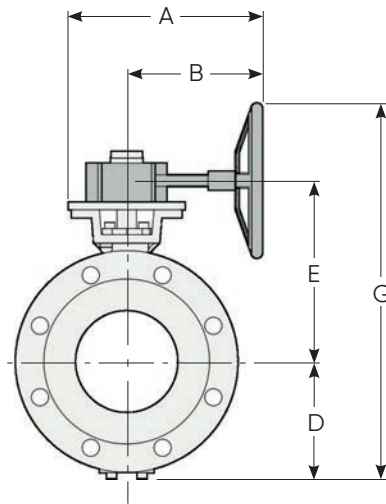
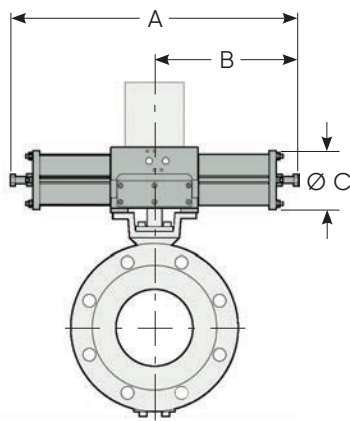

TABLE 5B: NAF SETBALL VALVES WITH WORM GEARS

DN	NPS	Max. differential pressure, seat of		NAF number	Dimensions, mm					Weight, kg		
		R-PTFE	Alloy 6		A	B	D	E	G	Wafer	Flanged	
Worm gear actuator as per Fk 70.76 ⁽¹⁾												
25	1	50	50	791051-11020	249	174	60	154	314	8	11.2	
40	1.5	50	50	791051-11020	249	174	75	159	334	9.5	13.8	
50	2	50	50	791051-11020	249	174	90	165	355	10.5	17	
65	2.5	35	35	791051-11020	249	174	101	173	374	13	19.5	
80	3	35	35	791051-11020	249	174	110	179	389	15.5	22	
100	4	25	25	791051-11020	249	174	120	201	421	19.5	29	
150	6	25	25	791051-11025	249	174	155	229	484	30	45	
200	8	25	25	791051-22030	328	243	185	279	614	51	73	
250	10	25	16	791051-22035	328	243	230	338	718	-	109	
250	10	25	25	791051-32035	416	291	230	345	775	-	117	
300	12	25	25	791051-33040	416	291	260	370	830	-	162	
350	14	25	16	791051-33050	416	291	290	425	915	-	191	
350	14	25	25	791051-43050	507	337	290	415	955	-	206	
400	16	16	11	791051-33050	416	291	308	433	941	-	227	
400	16	25	25	791051-43050	507	337	308	438	996	-	243	
500	20	20	20	791051-43050	507	337	371	515	1,136	-	380	
600	24	14	9	791051-45080	507	337	509	639	1,398	-	872	
600	24	20	17	791051-55080	591	421	509	639	1,348	-	878	
600	24	20	20	791051-65080	697	487	509	656	1,465	-	907	
700	28	15	10	791051-55080	591	421	569	740	1,509	-	1,138	
700	28	20	20	791051-65080	697	487	569	757	1,626	-	1,167	

⁽¹⁾ Available with locking device; for details, please contact your Flowserve representative



NAF 791290/791390

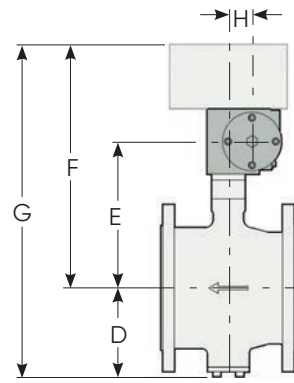

TABLE 6: NAF SETBALL VALVES WITH NAF TURNEX PNEUMATIC ACTUATORS (DOUBLE ACTING)

DN	NPS	Max. differential pressure, bar at supply of						NAF number	Dimensions, mm								Weight, kg	
		4 bar		5 bar		6 bar			A	B	C	D	E	F	G ⁽²⁾	H	Wafer	Flanged ⁽¹⁾
		R-PTFE	Alloy 6	R-PTFE	Alloy 6	R-PTFE	Alloy 6											
25	1	50	50	50	50	50	50	791390-0220	370	185	80	60	171	222	392	31	8	11.2
40	1.5	50	50	50	50	50	50	791390-0220	370	185	80	75	176	227	412	31	10	14.3
50	2	50	50	50	50	50	50	791390-0220	370	185	80	90	182	233	433	31	11	17.5
65	2.5	44	30	50	38	50	48	791390-0220	370	185	80	101	190	241	452	31	13	19.5
80	3	30	20	35	25	35	33	791390-0220	370	185	80	110	196	247	467	31	16	22.5
80	3	35	35	35	35	35	35	791390-1220	490	245	100	110	201	257	477	40	18	24.5
100	4	20	14	25	18	25	22	791390-0220	370	185	80	120	218	269	499	31	20	29.5
100	4	35	30	35	35	35	35	791290-1220	490	245	100	120	223	279	509	40	22	31.5
150	6	5	-	8	4	11	7	791390-0225	370	185	80	155	246	297	562	31	30	45
150	6	16	11	21	14	25	17	791290-1225	490	245	100	155	251	307	572	40	32	47
150	6	25	25	25	25	25	25	791290-2225	700	350	145	155	270	343	608	63	43	58
200	8	17	11	22	14	25	18	791290-2130	700	350	145	185	311	384	679	63	59	81
200	8	25	24	25	25	25	25	791290-2230	700	350	145	185	311	384	679	63	59	81
250	10	8	5	11	7	14	9	791290-2135	700	350	145	230	370	443	783	63	-	117
250	10	19	13	24	16	25	20	791290-2235	700	350	145	230	370	443	783	63	-	117
250	10	25	22	25	25	25	25	791290-3135	820	410	200	230	401	493	833	75	-	129
300	12	10	7	14	9	17	11	791290-2240	700	350	145	260	395	468	838	63	-	162
300	12	25	25	25	25	25	25	791290-3240	820	410	200	260	420	512	882	75	-	174
350	14	25	16	25	21	25	25	791290-3250	820	410	200	290	460	552	952	75	-	203
350	14	25	25	25	25	25	25	781390-4250	1110	555	260	290	488	591	991	100	-	240
400	16	16	11	22	15	25	19	791290-3250	820	410	200	308	483	575	993	75	-	240
400	16	25	25	25	25	25	25	791290-4250	1110	555	260	308	511	614	1,032	100	-	277
500	20	14	8	19	11	20	13	791290-3250	820	410	200	371	560	652	1,133	75	-	377
500	20	20	20	20	20	20	20	781390-4250	1,110	555	260	371	588	691	1,172	100	-	414
600	24	14	9	18	11	20	15	781390-4280	1,110	555	260	509	712	815	1,434	100	-	906
600	24	20	18	20	20	Max. air supply, 5 bar		781390-4580	1,250	695	395	509	712	815	1,434	100	-	950
700	28	8	4	11	7	14	9	781390-4280	1,110	555	260	569	813	916	1,595	100	-	1,166
700	28	17	11	20	15	Max. air supply, 5 bar		781390-4580	1,250	695	395	569	813	916	1,595	100	-	1,210

⁽¹⁾ Applies to weight of a PN 10 valve, including actuator and positioner

⁽²⁾ Including all direct-mounted Flowserve positioners

The above stated differential pressures apply for clean media, type water 20°C (68°F). For other media, please contact Flowserve. See also page 10.

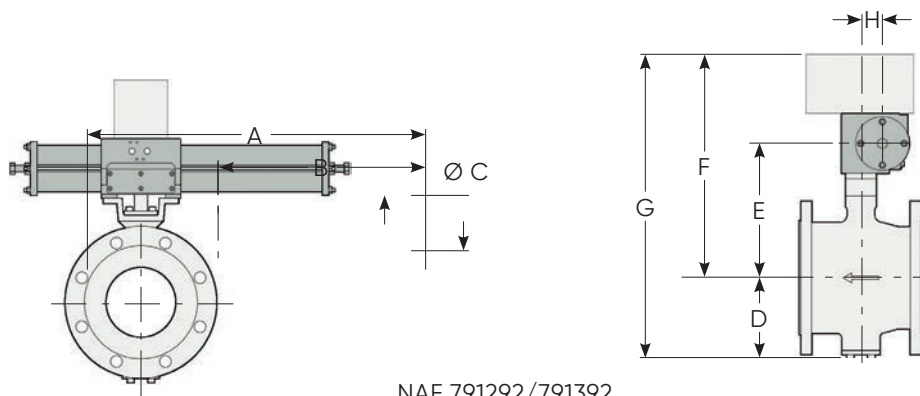

NAF 791292/791392

TABLE 7: NAF SETBALL VALVES WITH NAF TURNEX PNEUMATIC ACTUATORS (SPRING TO CLOSE)

DN	NPS	Max. differential pressure, bar at supply of						NAF number	Dimensions, mm								Weight, kg	
		4 bar ⁽³⁾		5 bar		6 bar			A	B	C	D	E	F	G ⁽²⁾	H	Wafer	Flanged ⁽¹⁾
		R-PTFE	Alloy 6	R-PTFE	Alloy 6	R-PTFE	Alloy 6											
25	1	50	46	50	50	50	50	791392-0220	455	270	80	60	171	222	392	31	9	12
40	1.5	50	34	50	39	50	39	791392-0220	455	270	80	60	176	227	412	31	11	15
40	1.5	50	50	50	50	50	50	791292-1220	635	390	100	60	181	237	422	40	15	19
50	2	42	28	48	33	48	33	791392-0220	455	270	80	90	182	233	433	31	12	19
50	2	50	44	50	50	50	50	791292-1220	635	390	100	90	185	243	443	40	16	23
65	2.5	18	12	32	20	32	20	791392-0220	455	270	80	101	190	241	452	31	14	21
65	2.5	38	25	50	35	50	35	791292-1220	635	390	100	101	195	251	462	40	18	25
80	3	13	8	16	10	16	10	791392-0220	455	270	80	110	196	247	467	31	17	24
80	3	22	15	30	20	30	20	791292-1220	635	390	100	110	201	257	477	40	21	28
80	3	35	35	35	35	35	35	791292-2220	890	540	145	110	220	293	513	63	35	42
100	4	10	5	13	6	13	6	791392-0220	455	270	80	120	218	269	499	31	21	31
100	4	12	9	19	13	19	13	791292-1220	635	390	100	120	223	279	494	40	25	35
100	4	35	35	35	35	35	35	791292-2220	890	540	145	120	242	315	530	63	39	49
150	6	3	-	6	3	6	3	791292-1225	635	390	100	155	251	307	572	40	35	50
150	6	25	25	25	25	25	25	791292-2225	890	540	145	155	270	343	608	63	49	64
200	8	15	10	20	14	20	14	791292-2230	890	540	145	185	311	384	679	63	65	87
200	8	25	25	25	25	25	25	791292-3230	1050	640	200	185	336	428	723	75	85	107
250	10	7	4	9	6	9	6	791292-2235	890	540	145	230	370	443	783	63	-	123
250	10	25	21	25	25	25	25	791292-3235	1,050	640	200	230	401	493	833	75	-	143
300	12	16	11	22	16	22	16	791292-3240	1,050	640	200	260	420	512	882	75	-	188
300	12	25	25	25	25	25	25	791392-4240	1,520	965	260	260	448	551	921	100	-	245
350	14	8	6	13	9	13	9	791292-3250	1,050	640	200	290	460	552	952	75	-	217
350	14	28	18	25	24	25	24	791392-4250	1,520	965	260	290	488	591	991	100	-	274
400	16	6	3	9	5	9	5	791292-3250	1,050	640	200	308	483	575	993	75	-	254
400	16	19	12	25	16	25	16	791392-4250	1,520	965	260	308	511	614	1,032	100	-	311
400	16	25	16	25	16	Max. air supply, 5 bar		791392-4550	1,665	965	395	308	511	614	1,032	100	-	356
500	20	3	-	7	4	7	4	791292-3250	1,050	640	200	371	560	652	1,132	75	-	391
500	20	15	9	20	13	20	13	791392-4250	1,520	965	260	371	588	691	1,172	100	-	448
500	20	20	20	20	20	20	20	791392-5250	2,210	1,370	395	371	642	761	1,242	150	-	833
600	24	3	-	8	5	8	5	791392-4280	1,520	965	260	509	712	815	1,434	100	-	942
600	24	8	5	8	5	Max. air supply, 5 bar		791392-4580	1,665	965	395	509	712	815	1,434	100	-	987
600	24	20	20	20	20	20	20	791392-5280	2,210	1,370	395	509	766	885	1,504	150	-	1,327
700	28	18	12	20	19	20	19	791392-5280	2,210	1,370	395	569	867	986	1,665	150	-	1,587

⁽¹⁾ Applies to weight of a PN 10 valve, including actuator and positioner

⁽²⁾ Including all direct-mounted Flowserve positioners

⁽³⁾ Actuators with alternative spring rates for low supply pressure are available from sizing tool, Performance!Nxt.

The above stated differential pressures apply for clean media, type water 20°C (68°F). For other media, please contact Flowserve. See also page 10.



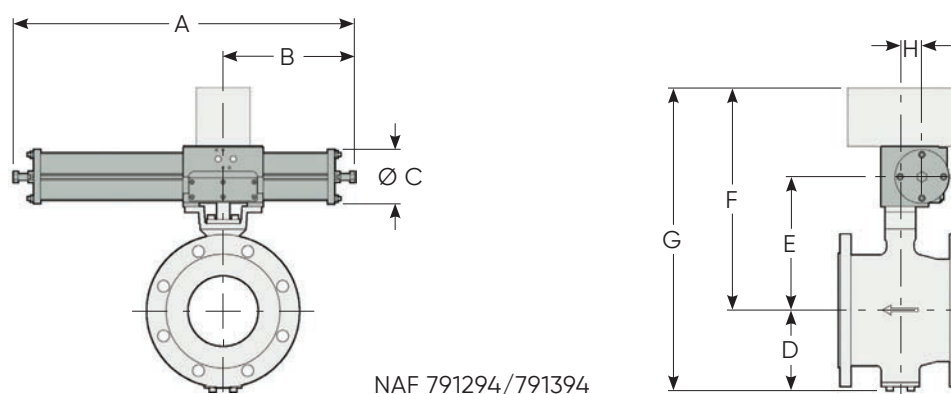

NAF 791294/791394

TABLE 8: NAF SETBALL VALVES WITH NAF TURNEX PNEUMATIC ACTUATORS (SPRING TO OPEN)

DN	NPS	Max. differential pressure, bar at supply of						NAF number	Dimensions, mm								Weight, kg	
		4 bar ⁽³⁾		5 bar		6 bar			A	B	C	D	E	F	G ⁽²⁾	H	Wafer	Flanged ⁽¹⁾
		R-PTFE	Alloy 6	R-PTFE	Alloy 6	R-PTFE	Alloy 6											
25	1	30	20	50	50	50	50	791394-0220	455	270	80	60	171	222	392	31	9	12.2
25	1	45	30	50	50	50	50	791294-1220	635	390	100	60	176	232	402	40	13	16.2
40	1.5	20	14	50	46	50	50	791394-0220	455	270	80	75	176	227	412	31	11	15.3
40	1.5	32	22	50	50	50	50	791294-1220	635	390	100	75	181	237	422	40	15	19.3
50	2	18	11	50	39	50	43	791394-0220	455	270	80	90	182	233	433	31	12	18.5
50	2	26	17	50	50	50	50	791294-1220	635	390	100	90	187	243	443	40	16	22.5
65	2.5	7	4	28	17	31	20	791394-0220	455	270	80	101	190	241	452	31	14	100
65	2.5	11	7	50	35	50	45	791294-1220	635	390	100	101	195	251	462	40	18	24.5
80	3	-	-	18	12	20	14	791394-0220	455	270	80	110	196	247	467	31	17	23.5
80	3	8	4	28	19	35	26	791294-1220	635	390	100	110	201	257	477	40	21	27.5
100	4	6	3	19	13	25	17	791294-1220	635	390	100	120	223	279	494	40	25	34.5
100	4	35	32	35	35	35	35	791294-2220	890	540	145	120	242	315	530	63	39	49
150	6	-	-	5	3	8	5	791294-1225	635	390	100	155	251	307	572	40	35	50
150	6	17	11	25	25	25	25	791294-2225	890	540	145	155	270	343	608	63	49	64
200	8	7	4	20	13	25	18	791294-2230	890	540	145	185	311	384	679	63	65	87
200	8	25	19	25	25	25	25	791294-3230	1050	640	200	185	336	428	723	75	85	107
250	10	-	-	10	6	12	8	791294-2235	890	540	145	230	370	443	783	63	-	123
250	10	14	9	25	25	25	25	791294-3235	1,050	640	200	230	401	493	833	75	-	143
300	12	7	4	20	14	25	20	791294-3240	1,050	640	200	260	420	512	882	75	-	188
300	12	17	11	25	25	25	25	791394-4240	1,520	640	200	260	448	551	921	100	-	245
350	14	-	-	12	8	19	12	791294-3250	1,050	640	200	290	460	552	952	75	-	217
350	14	10	6	25	21	25	25	791394-4250	1,520	965	260	290	488	591	991	100	-	274
400	16	-	-	9	5	12	7	791294-3250	1,050	640	200	308	483	575	993	75	-	254
400	16	6	3	22	14	25	21	791394-4250	1,520	965	260	308	511	614	1,032	100	-	311
400	16	25	21	25	21	Max. air supply, 5 bar	20	791394-4550	1,665	965	395	308	511	614	1,032	100	-	356
500	20	-	-	16	11	20	17	791394-4250	1,520	965	260	371	588	691	1,172	100	-	448
500	20	20	17	20	17	Max. air supply, 5 bar	20	791394-4550	1,665	965	395	371	588	691	1,172	100	-	493
600	24	11	7	11	7	Max. air supply, 5 bar	20	791394-4580	1,665	965	395	509	712	815	1,434	100	-	987
600	24	8	4	20	17	20	20	791394-5280	2,210	1,370	395	509	766	885	1,504	150	-	1,327
700	28	7	3	7	3	Max. air supply, 5 bar	20	791394-4580	1,665	965	395	569	813	916	1,595	100	-	1,247
700	28	-	-	16	11	20	20	791394-5280	2,210	1,370	395	569	867	986	1,665	150	-	1,587
700	28	20	20	20	20	Max. air supply, 5 bar	20	791394-5580	2,260	1,370	550	569	867	986	1,665	150	-	1,687

⁽¹⁾ Applies to weight of a PN 10 valve, including actuator and positioner

⁽²⁾ Including all direct-mounted Flowserve positioners

⁽³⁾ Actuators with alternative spring rates for low supply pressure are available from our sizing tool, Performance!Nxt.

The above stated differential pressures apply for clean media, type water 20°C (68°F). For other media, please contact Flowserve. See also page 10.



Product code

Example:

88 8 0 E B - 0100 - 0 A XA
Code 1 2 3 4 5 6 7 8 9

1. Valve type

87 NAF Setball
Z-87 NAF Setball with Z-trim option

2. Material ⁽¹⁾

Body	Ball sector
6 WCB (~EN1.0619)	CF8M/316 (~EN1.4408) ⁽⁴⁾
8 CF8M/316 (~EN1.4408)	CF8M/316 (~EN1.4408)⁽⁴⁾

3. Pressure rating

Wafer version

PN ratings	ANSI ratings
DN 25 to 65	Sizes 1 to 2 in. PN 10 to 40/ANSI 150 to 300
0 DN 80 to 100	Sizes 2.5 to 4 in. PN 10 to 25/ANSI 150
DN 150 to 200	Sizes 6 to 8 in. PN 10 to 16/ANSI 150

Flanged version

2 PN 10	(DN 200 to 700) ⁽²⁾
3 PN 16	(DN 80 to 700)
4 ANSI Class 150	(Sizes 1 to 28 in.)
5 PN 25	(DN 200 to 700) ⁽²⁾
6 PN 40	(DN 25 to 700)
7 ANSI Class 300	(Sizes 1 to 28 in.) ⁽⁴⁾

4. Stem bearing

E R-PTFE + stainless steel

5. Body type

B Wafer
F Flanged

⁽¹⁾ For material CF8, CF3M, CG3M, CG8M, Duplex EN 1.4470, CW-12MW, M35-01, CK3MCuN, titanium B367 Grade C2, etc., please contact Flowserve.

⁽²⁾ Size DN 25 to 65 have the same flange dimensions in PN 10, 16, 25 and 40. Choose PN 40 for these valves. Sizes 80 to 150 have the same dimensions in PN 10 and PN 16. Choose PN 16 for these sizes. Sizes 80 to 150 have the same dimensions in PN 25 and PN 40. Choose PN 40 for these sizes.

⁽³⁾ Not available in size 2.5 in.

⁽⁴⁾ Ball sector material in the Z-trim version is Duplex EN 1.4470.

6. Size

	PN ratings		ANSI ratings
	DN		Size
2505	25/5	1T05	1 in. /5
2510	25/10	1T10	1 in. /10
2515	25/15	1T15	1 in. /15
2520	25/20	1T20	1 in. /20
0040	40	01.5	1.5 in.
0050	50	0002	2 in.
0065	65	02.5	2.5 in.
0080	80	0003	3 in.
0100	100	0004	4 in.
0150	150	0006	6 in.
0200	200	0008	8 in.
0250	250	0010	10 in.
0300	300	0012	12 in.
0350	350	0014	14 in.
0400	400	0016	16 in.
0500	500	0020	20 in.
0600	600	0024	24 in.
0700	700	0028	28 in.

7. Seat and ball sector overlay

	Seat	Ball sector overlay
0	Alloy 6	Hard chrome
v	R-PTFE, max. 225°C (437°F)	-

8. Seals

	Seat seal	Stem packing
A	R-PTFE	Zebra-CL™ (R-PTFE/PTFE V-rings)
B	R-PTFE	Safeguard (R-PTFE/PTFE V-rings, spring loaded)

9. Options

D Degreased version
I Internal O-rings for sealing the stem from the medium
XA ATEX certified





ANDRITZ

All data, information, statements, photographs and graphic illustrations in this leaflet are without any obligation and raise no liabilities to or form part of any sales contracts of ANDRITZ AG or any affiliates for equipment and/or systems referred to herein. © ANDRITZ AG 2024. All rights reserved. No part of this copyrighted work may be reproduced, modified or distributed in any form or by any means, or stored in any database or retrieval system, without the prior written permission of ANDRITZ AG or its affiliates. Any such unauthorized use for any purpose is a violation of the relevant copyright laws. ANDRITZ AG, Stattegger Strasse 18, 8045 Graz, Austria. NAF ProCap Capping Valve Technical bulletin EN 1.0/2024.



JOHANNESBURG
Tel: 011 397 2833

DURBAN
Tel: 031 579 2593

South Africa:
0861 103 103

E-mail: sales@valve.co.za
www.valve.co.za

