

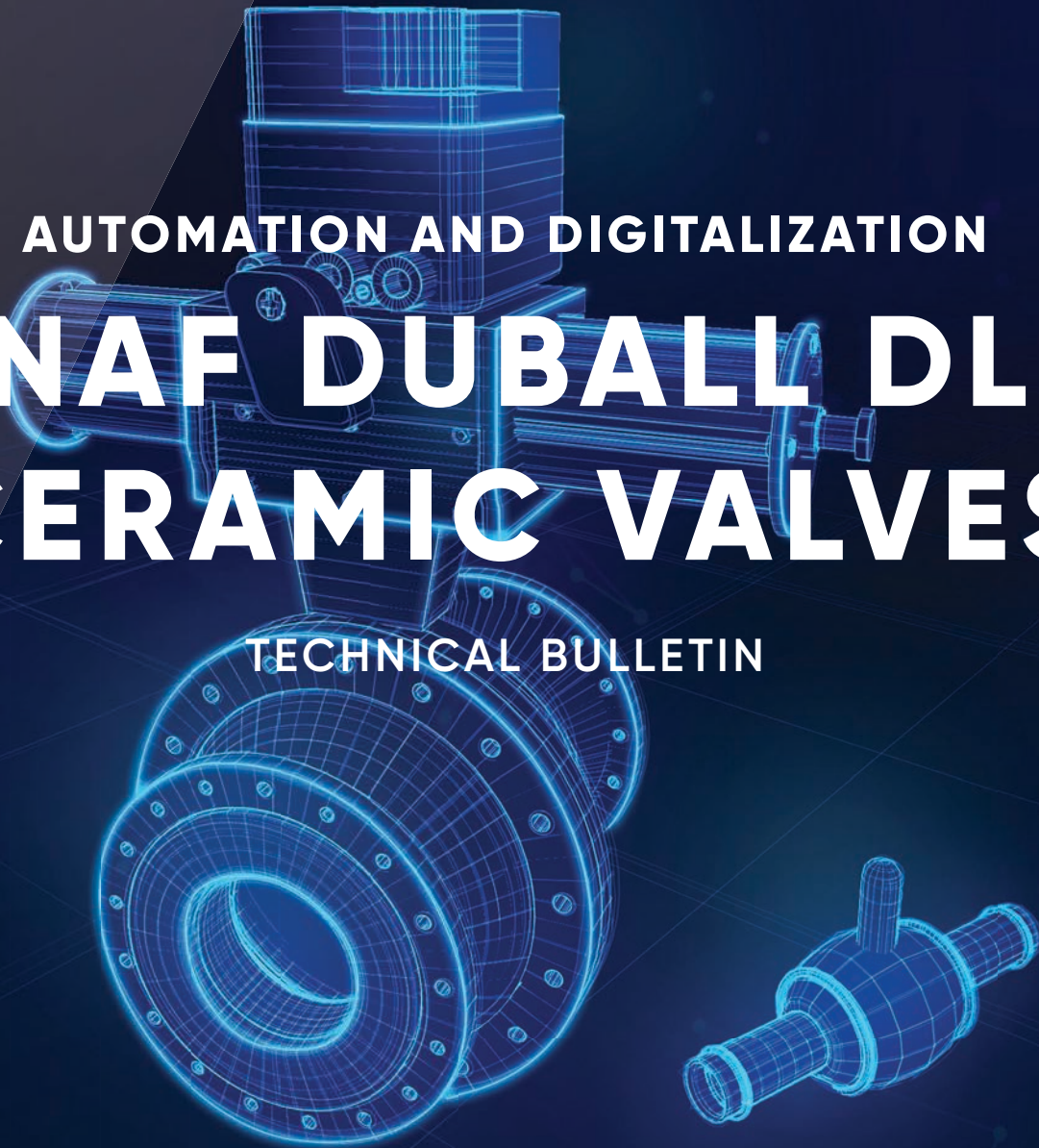

AUTOMATION AND DIGITALIZATION

# NAF DUBALL DL CERAMIC VALVES

TECHNICAL BULLETIN



**ANDRITZ**

ENGINEERED SUCCESS

# Primary characteristics

NAF-Ceramic is a ball valve all-lined with ceramic. It is primary intended for control but has a sealing class as for a shut-off valve.

The valve has:

- Internally all-lined with ceramic for erosive and abrasive media.
- An easy-to-service arrangement, due to the off-center joint face of the valve body, which allows for easy replacement of the ball and seals, without the need for removing the stem and actuator.
- A floating ball that seals in both directions of flow and at low differential pressures.
- Sturdy, blowout-proof rigidly journalled stem and a drive arrangement between the ball and stem that transmits torque evenly.
- Stem seal with maintenance-free O-ring seals.
- The NAF standard for mounting the actuator, which simplifies installation and results in a compact valve/actuator unit.

**CE-marked** according to Pressure Equipment Directive (PED 97/23/EG) module H, category III.

**TABLE 1: TECHNICAL SPECIFICATIONS**

Options	PN
<b>Material</b>	Stainless steel, Ceramic
<b>Dimensions</b>	DN 25–100 (1"–4")
<b>Pressure class</b>	PN 40
<b>Face-to-face lengths</b>	PN 40: EN 558-1 series 4 (SSG 1043) ANSI 300: ANSI B 16.10 Class 300 short
<b>Valve design</b>	ANSI B16.34 and EN 12 516
<b>Connections</b>	Flanges acc. to DIN or ANSI B 16.5
<b>Temperature range</b>	-30 - 200OC, (diagram on page 4.)
<b>Test pressure:</b>	Open valve 1,5xPN Closed valve 1,1xPN
<b>Sealing class</b>	Testing medium is water. IEC 534-4 Class V ANSI / FCI70-2



# Applications

NAF-Ceramic can be used both as control and shut-off valve for difficult applications with erosive and abrasive media.

The valve represents a concrete result of our product philosophy which is focused on functionality, high quality and low life cycle costs, and is based on concentrating our range to a limited number of valve types, but all of them suitable for a wide variety of applications.



# Working pressure, differential pressure and temperature

The maximum working pressure and temperature in the body depends on pressure class according to respectively flange standards. For EN1092-1:2001 see diagram below. The differential pressure when the valve is closed is max 25 bar, and the temperature dependence is shown in the diagram on page 3. The stem gland with EPDM O-ring can be used for temperatures up to 200°C. For higher temperatures, consult NAF. The ceramic parts must not be exposed to thermal shocks.

## MAX WORKING PRESSURE PN VALVE

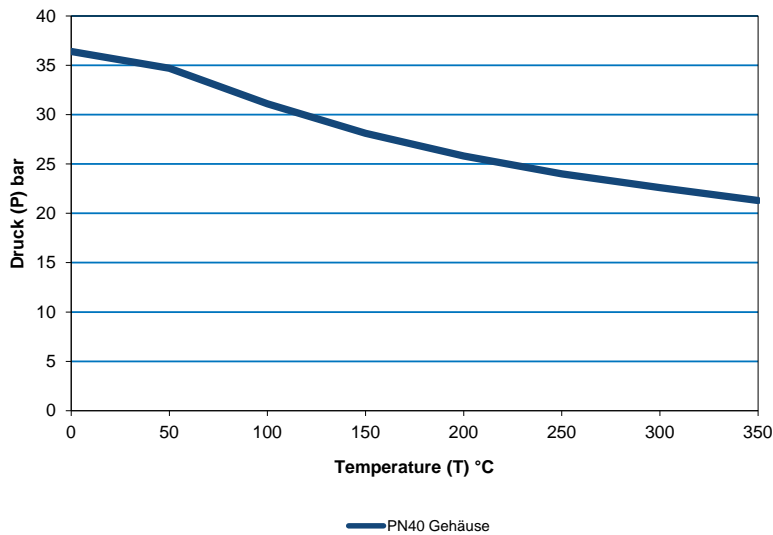

## MAX WORKING PRESSURE PN VALVE

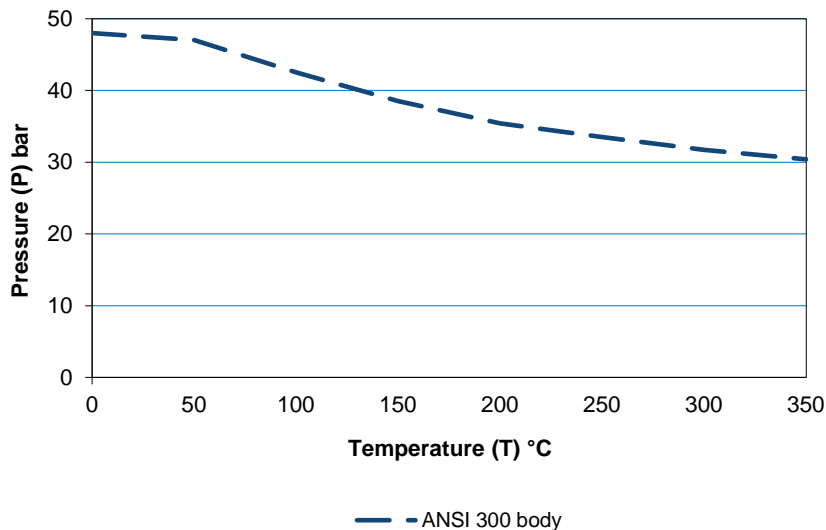

## MAX DP

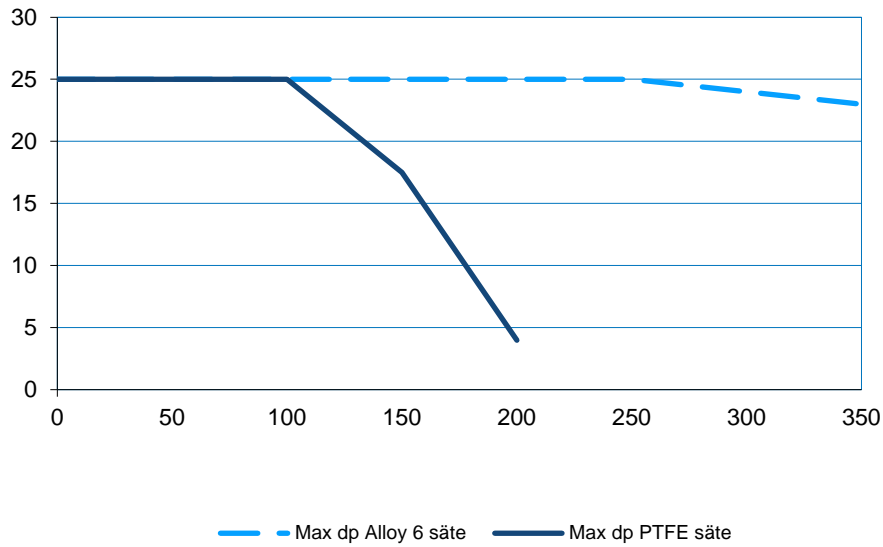

**TABLE 1: FLOW CAPACITIES AND CHARACTERISTICS**

DN/ Bore	K <sub>v</sub> at an opening angle of															
	15°	20°	25°	30°	35°	40°	45°	50°	55°	60°	65°	70°	75°	80°	85°	90°
25/15	0,5	0,6	0,9	1,0	1,2	1,5	1,9	2,3	2,8	3,4	4,0	4,8	6,3	7,7	9,2	11
40/25	1,5	1,7	2,5	2,9	3,5	4,4	5,4	6,6	8,2	9,8	12	14	18	22	27	32
50/32	2,8	3,1	4,6	5,4	6,4	8,2	10	12	15	18	21	26	34	41	50	59
80/50	6,1	6,8	10	12	14	18	22	27	33	40	47	57	74	91	109	130
100/65	11	12	18	21	25	31	38	47	58	70	82	99	130	159	191	227

C<sub>v</sub> = 1,16 x K<sub>v</sub>

**TABLE 2: MATERIAL SPECIFICATION**

Item	Qty	Part	Material
1	1	Body	EN1.4408 / CF8M
2	1	Body	EN1.4408 / CF8M
3	1	Ball	Zirconium oxide
4	1	Stem assembly	EN1.4460
5	2	Lining	Aluminium oxide
7	1	Washer	2343-02
8	1	Washer	8176-05
9	2	Bushing	8176-06
10	2	O-ring	EPDM
11	6	Screw	A4
12	6	Nut	A4
13	1	Washer	8176-01
17	2	Seal ring	8176-01
18	1	Seal ring	PTFE
22	1	Key	A4
23	1	Backing ring	Spring steel
24	1	Washer	Spring steel

**MAX WORKING PRESSURE PN VALVE**

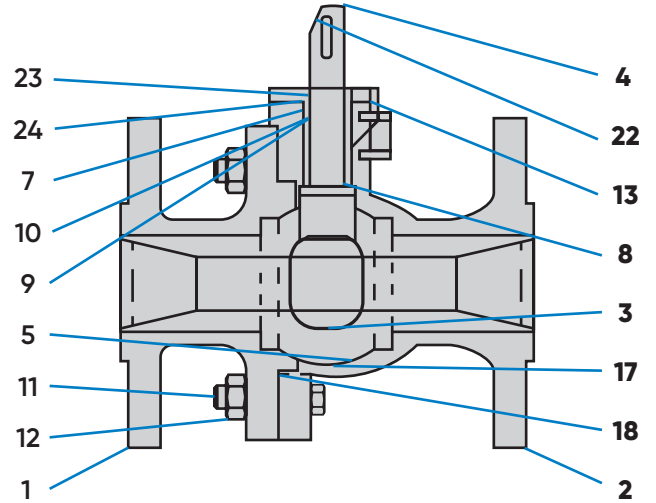

**TABLE 3: OPERATING TORQUE IN NM**

DN	Differential pressure bar				
	5	10	16	20	25
25	8	10	12	15	18
40	15	20	23	30	35
50	18	25	32	38	45
80	25	36	48	60	70
100	36	60	85	105	130

### Operating torque

The minimum design differential pressure for selecting the actuator is 5 bar.

### Sizing of control valves

We have a user friendly valve calculation program which can be ordered through your NAF representative. The program is based on calculating formula according to the standards IEC 60534 and ISA S75.01.

# Dimensions and mass

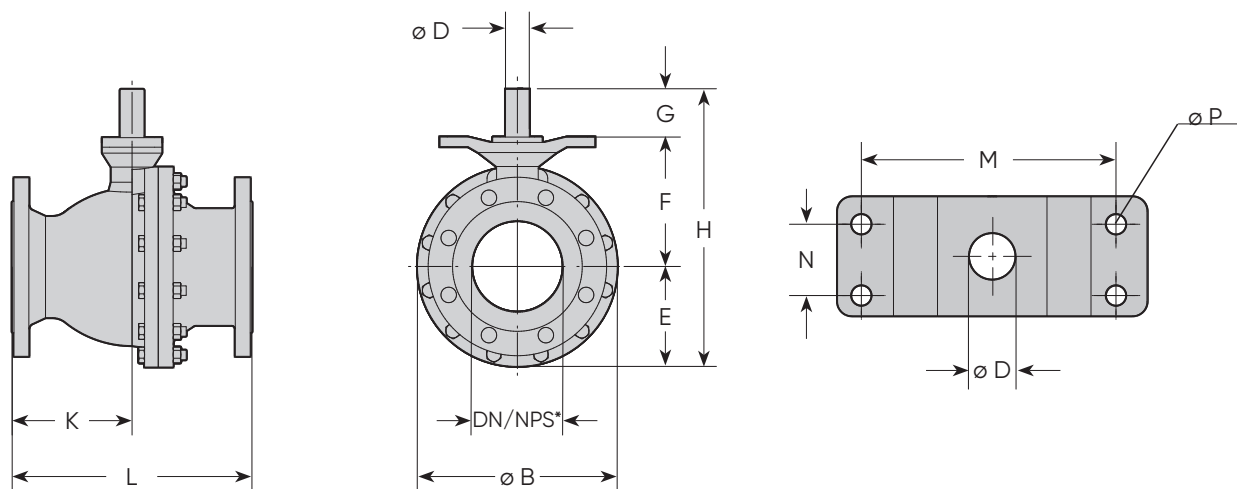
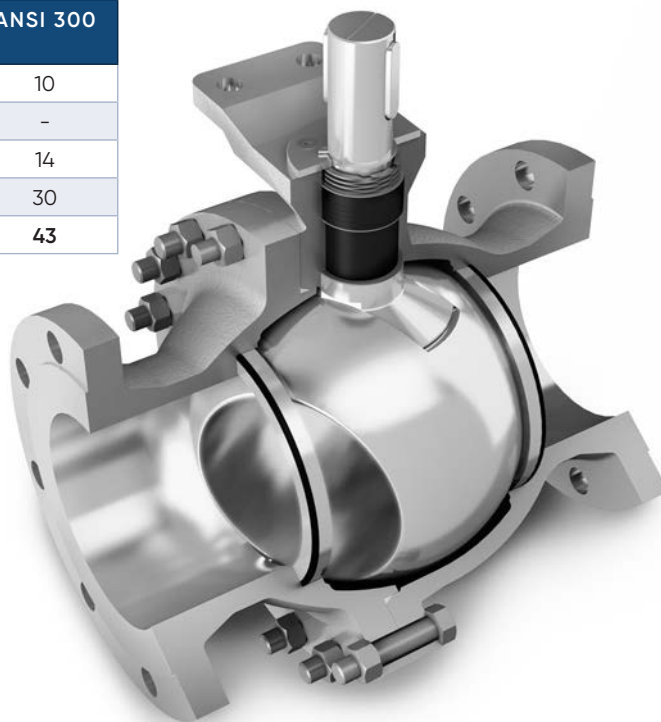

**TABLE 4:**

Valve DN	B	D	E	F	G	H	K PN40	L PN40
25 1"	124	16	62	83	38	183	66	165
40 -	150	16	75	91	38	204	95	190
50 2"	165	20	83	106	43	232	108	216
80 3"	214	25	107	137	50	284	142	283
100 4"	244	25	122	152	50	324	153	305

**TABLE 5:**

Valve DN	K	L	M	N	P	Mass kg	
						PN 40	ANSI 300
25 1"	66	165	115	30	11	9	10
40 -	-	-	115	30	11	11	-
50 2"	108	216	115	30	11	14	14
80 3"	142	283	115	30	11	27	30
100 4"	153	305	115	30	11	36	43



# NAF-Ceramic with pneumatic actuator

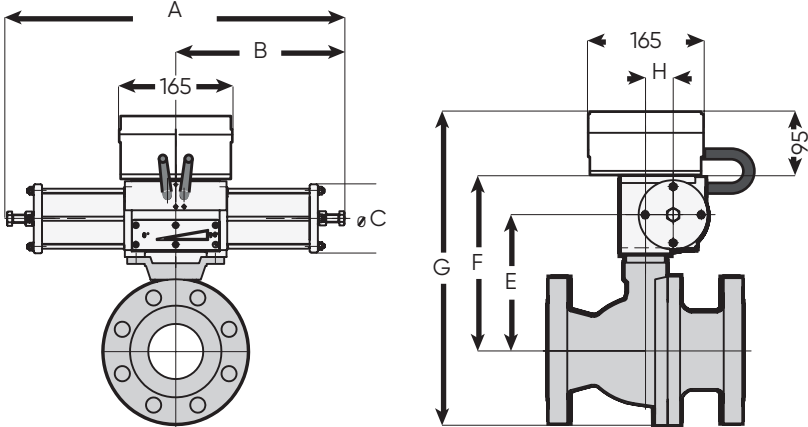

**TABLE 6: NAF-CERAMIC WITH PNEUMATIC ACTUATOR**

Valve DN	Max. dP bar at supply of			NAF-No	Dimension in mm								Mass kg 1)
	4 bar	5 bar	6 bar		A	B	C	D	E	F	G <sup>2)</sup>	H	
Double acting acc. to Fk74.59													
25	25	25	25	791390-0216	370	185	80	62	133	185	342	31	15
40	25	25	25	-0216	370	185	80	75	141	193	363	31	17
50	25	25	25	-0220	370	185	80	83	156	208	385	31	20
80	25	25	25	-0225	370	185	80	107	187	239	441	31	33
100	15	19	25	-0225	370	185	80	122	202	264	471	31	42
100	25	25	25	791290-1225	490	245	100	122	207	264	481	40	44

1) Valid for actuator and valve in PN 40  
 2) Incl NAF positioner

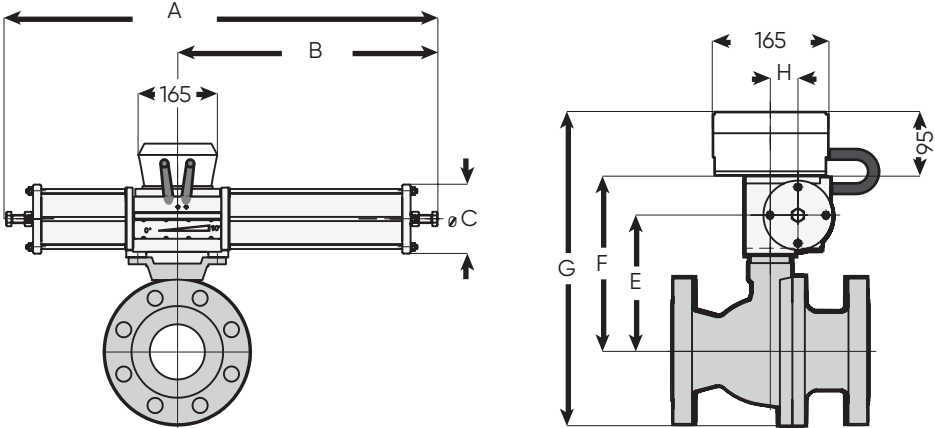

**TABLE 7:**

Val- ve DN	Max dP bar at supply of			NAF-No	Dimension in mm								Mass kg <sup>1)</sup>
	4 bar	5 bar	6 bar		A	B	C	D	E	F	G <sup>2)</sup>	H	
<b>Single acting Spring, closes acc. to Fk 74.59</b>													
25	20	25	25	791292-0216	455	270	80	62	133	185	342	31	16
40	20	25	25	-0216	455	270	80	75	141	193	363	31	18
40	25	25	25	-1216	635	390	100	75	146	203	373	40	22
50	15	25	25	-0220	455	270	80	83	156	208	385	31	21
50	25	25	25	-1220	635	390	100	83	161	218	395	40	25
80	25	25	25	-1225	635	390	100	107	192	249	451	40	38
100	13	25	25	-1225	635	390	100	122	207	264	481	40	47
100	25	25	25	-2225	890	540	145	122	227	300	517	63	61

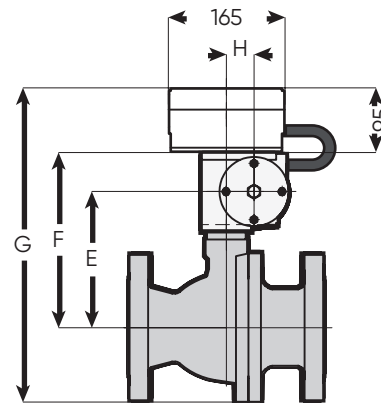
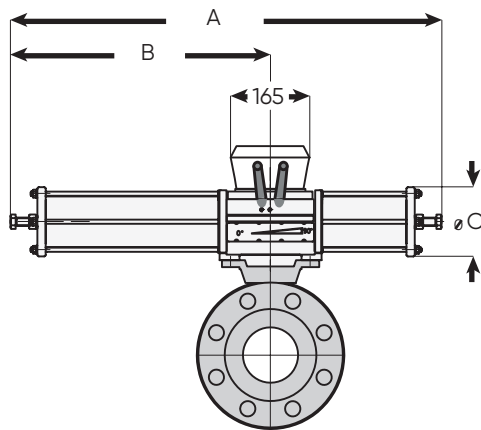

**TABLE 8:**

Valve DN	Max dP bar at supply of			NAF-No	Dimension in mm								Mass kg <sup>1)</sup>
	4 bar	5 bar	6 bar		A	B	C	D	E	F	G <sup>2)</sup>	H	
<b>Single acting Spring, closes acc. to Fk 74.59</b>													
25	20	25	25	791294-0216	455	270	80	62	133	185	342	31	16
40	-	25	25	-0216	455	270	80	75	141	193	363	31	18
40	25	25	25	-1216	635	390	100	75	146	203	373	40	22
50	-	20	25	-0220	455	270	80	83	156	208	385	31	21
50	20	25	25	-1220	635	390	100	83	161	218	395	40	25
80	12	25	25	-1225	635	390	100	107	192	249	451	40	38
80	25	25	25	-2225	890	540	145	107	212	285	496	63	52
100	5	19	22	-1225	635	390	100	122	207	264	481	40	47
100	25	25	25	-2225	890	540	145	122	227	300	517	63	61

1) Valid for actuator and valve in PN 40

2) Incl NAF positioner

# Product code NAF-Ceramic

Example:

	<u>88</u>	<u>8</u>	<u>6</u>	<u>9</u>	<u>8</u>	-	<u>0100</u>	-	<u>2</u>	<u>3</u>
<b>Code</b>	1	2	3	4	5		6		7	8

## Accessories

NAF's pneumatic actuators, see data sheet Fk74.59 can be equipped with a large number of accessories.

The following are included in NAF's standard programme and are suitable for direct mounting to NAF pneumatic actuators.

## Valve positioner

Pneumatic and electro-pneumatic valve positioner, see data sheet Fk41.82. Intelligent valve positioner, see data sheet Fk41.85.

## Solenoid valves

See data sheet Fk79.17.

## Filter regulator

Can be delivered (part no. 79-SMC-AW20K-F02CE-C).

## Electrical position indication

See data sheet Fk79.10.

## Terminal box

The actuator can be equipped with a junction box (part No.

349 20930) of cast aluminium containing terminal blocks for connecting the solenoid valve and position sensors.

### 1. Valve type

**88 Ball valve**

### 2. Material (Body)

**8 1.4408 / CF8M**

### 3. Pressure rating

**6** PN 40 (DN 25 – 100)<sup>1)</sup>  
**7** ANSI Class 300 (Size 1" – 4")

### 4. Stem Seal

**9** O-ring EPDM, max 200°C

### 5. Seals

**8** Internally all lined with Ceramic

### 6. Dimension

DIN	ANSI	DN	Size
0025	25	25	0001 1"
0040	40	40	-
0050	50	50	0002 2"
0080	80	80	0003 3"
0100	100	100	0004 4"

### 7. Seat/lining

**2** Al O<sub>2</sub> Ceramic

### 8. Ball

**3** Zr O<sub>2</sub> Ceramic



# ANDRITZ

All data, information, statements, photographs and graphic illustrations in this leaflet are without any obligation and raise no liabilities to or form part of any sales contracts of ANDRITZ AG or any affiliates for equipment and/or systems referred to herein. © ANDRITZ AG 2024. All rights reserved. No part of this copyrighted work may be reproduced, modified or distributed in any form or by any means, or stored in any database or retrieval system, without the prior written permission of ANDRITZ AG or its affiliates. Any such unauthorized use for any purpose is a violation of the relevant copyright laws. ANDRITZ AG, Stattegger Strasse 18, 8045 Graz, Austria. NAF ProCap Capping Valve Technical bulletin EN 1.0/2024.



JOHANNESBURG  
Tel: 011 397 2833

**South Africa:**  
**0861 103 103**

DURBAN  
Tel: 031 579 2593

E-mail: [sales@valve.co.za](mailto:sales@valve.co.za)  
[www.valve.co.za](http://www.valve.co.za)

