



AUTOMATION AND DIGITALIZATION

# NAF DUBALL DL BALL VALVES

TECHNICAL BULLETIN



**ANDRITZ**

ENGINEERED SUCCESS

# Primary characteristics

The NAF Duball DL valve is a full-bore ball valve which is equally suitable for isolation, on/off and modulating control applications. The NAF Duball DL valve is supplied as standard in stainless steel or carbon steel, but is also available in other materials, such as duplex stainless steel, titanium, etc.

The NAF Duball DL valve is the fourth generation of the Duball valve portfolio, one of the most proven ball valve portfolios in the industry.

The valve has:

- A **spring-loaded stem seal packing** that provides long, maintenance-free and safe operation in automated on/off and control service
- **Direct actuator mounting capabilities** of the NAF Turnex actuator that provide a high-performance, vibration-resistant, compact valve package
- A sturdy, **blowout-proof stem** with a long foot providing a high-torque transmission with a **minimum mechanical backlash**
- A floating ball that provides **bidirectional tightness**
- The **unique Z-trim** option that **minimizes cavitation and noise** and has **excellent control characteristics**
- An **extensive size range**, DN 25 to 400, NPS 1 to 16
- An **easy-to-service arrangement**, due to the off-center joint face of the valve body, which allows for easy replacement of the ball and seals, without the need for removing the stem and actuator
- **Metal seats** with a rigid welded overlay of Alloy 6 or alternatively, **metal encapsulated, reinforced PTFE seats**
- A wide range of **optional versions**, including **fire-safe** tested versions per API 607/ISO 10497
- **CE-marked** according to Pressure Equipment Directive (PED 2014/68/EU) module H, category III. For module H1, category IV, contact Flowserve.

**TABLE 1: TECHNICAL SPECIFICATIONS FOR STANDARD DESIGN**

Options	PN	ASME
<b>Material</b>	Stainless steel, carbon steel	Stainless steel, carbon steel
<b>Size range</b>	DN 25 to 400	NPS 1 to 16
<b>Pressure ratings</b>	PN 10 to 40	ASME Class 150 to 300
<b>Face-to-face lengths</b>	PN 10 to 16: EN558-1 series 12 (SSG 1042) PN 25 to 40: EN558-1 series 4 (SSG 1043)	Class 150: ASME B16.10 Class 150 long Class 300: NPS 1 to 12, ASME B16.10 short NPS 14 to 16, ASME B16.10 long
<b>Valve design</b>	EN 12 516	ASME B16.34
<b>Installation method</b>	Flanges to EN	ASME B16.5
<b>Temperature range</b>	Standard version: -30°C to 250°C (-22°F to 482°F) High-temperature version: available up to 500°C (932°F)	
<b>Test procedure</b>	Body: 1.5 x maximum working pressure Seat: 1.1 x maximum allowed differential pressure Testing medium is water with inhibitor <sup>1</sup>	
<b>Tightness class</b>	Soft seats: EN 12266-1:2012, rate A (ISO 5208, rate A), tested with water <sup>1</sup> Metal seats: EN 60534-4 Class V, ASME FCI 70-2 Class V, tested with water <sup>1</sup>	

<sup>1</sup> Gas test upon request



# Applications

The excellent characteristics of NAF Duball DL valve are particularly beneficial under the most challenging operating conditions in the process industry, where difficult media and demanding pressure conditions make severe demands on the design, materials and performance.

NAF Duball DL valve is recommended for applications in the following industries:

- Chemical and Petrochemical
- Pulp and Paper
- Oil and Gas
- Power Stations
- Metals and Mining
- General Industries

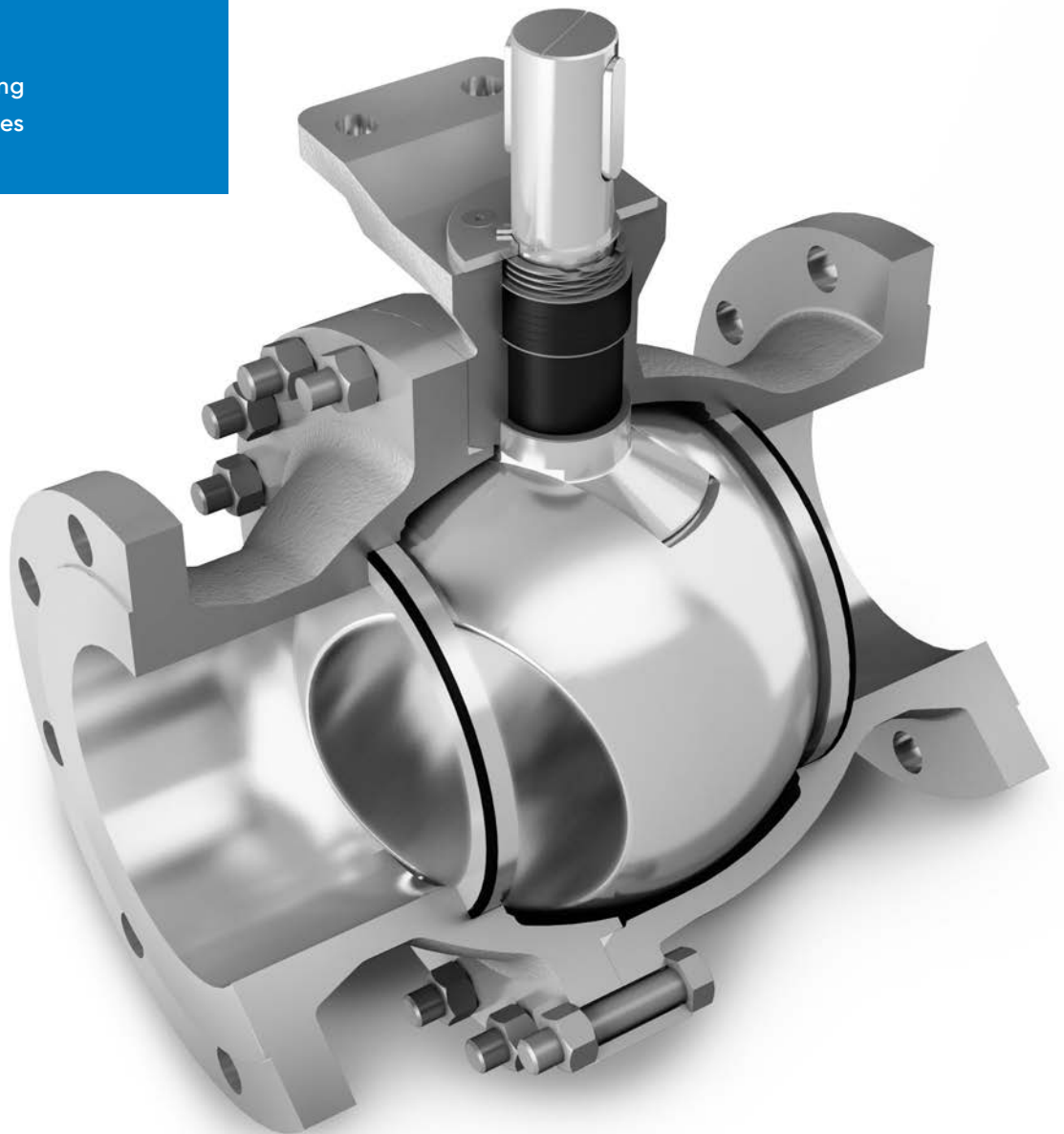

# Materials of construction

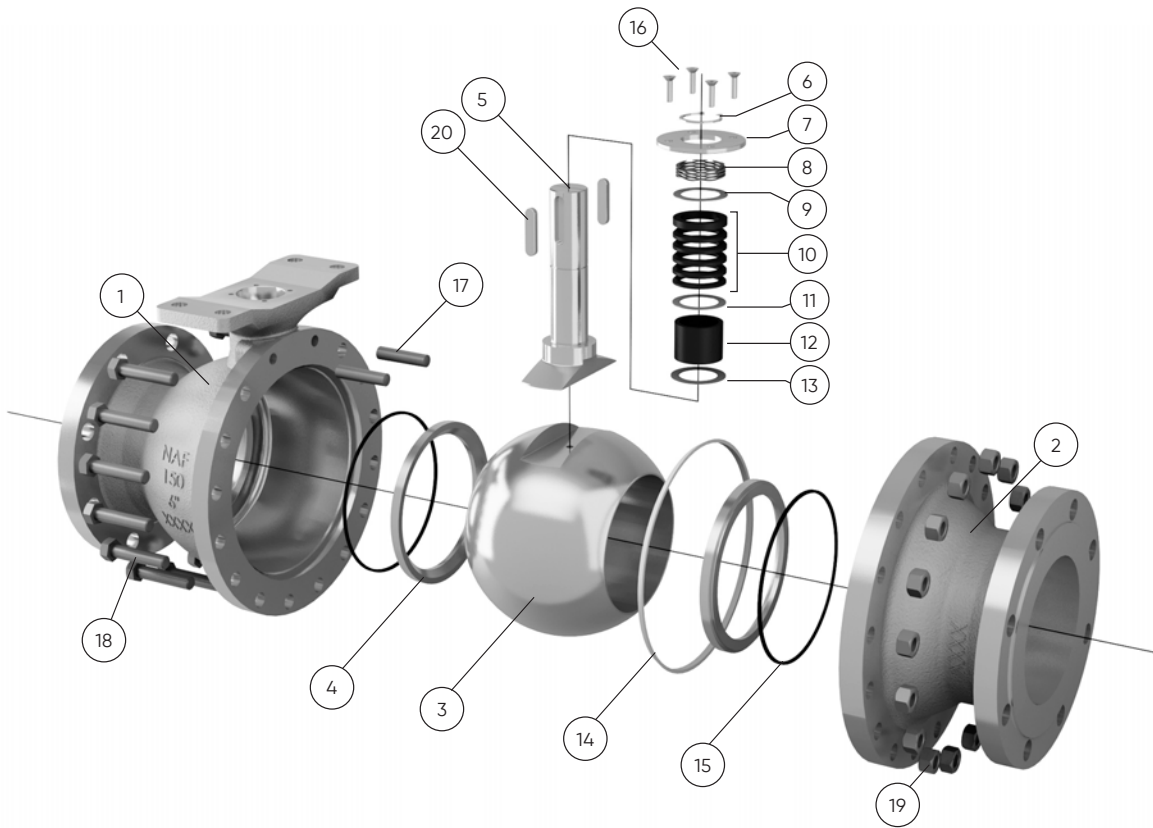

**TABLE 2: MATERIALS<sup>1</sup> (METAL SEATED, STANDARD VERSION)**

Item	Qty.	Part	Stainless steel	Carbon steel
1	1	Body, main	CF8M <sup>4</sup> /1.4408 <sup>5</sup>	WCB <sup>6</sup>
2	1	Body, cover	CF8M/1.4408	WCB
3	1	Ball	CF8M/1.4408 + hard chrome plated	
4 <sup>2</sup>	2	Seat ring	Stainless steel/Alloy 6	
5	1	Stem	EN 1.4460 (Type AISI 329)	
6	1	Circlip	A2	
7	1	Cover	AISI 316L/EN 1.4404	
8	1	Spring	17-7PH	
9	1	Washer	AISI 316L/EN 1.4404	
10 <sup>2</sup>	1	Stem packing	R-PTFE carbon-reinforced	
11 <sup>2</sup>	1	Washer	AISI 316 /EN 1.4404	
12 <sup>2</sup>	1	Bushing	R-PTFE carbon-reinforced	
13 <sup>2</sup>	1	Anti-friction washer	PTFE + stainless steel	
14 <sup>2</sup>	1	Body seal	PTFE	
15 <sup>2</sup>	2	Seat seal	R-PTFE carbon-reinforced	
16	X <sup>3</sup>	Screw	A4	
17	2	Stud	A4/ASTM A193 Grade B8M	ASTM A193 Grade B7M
18	X <sup>3</sup>	Bolt	A4/ASTM A193 Grade B8M	ASTM A193 Grade B7M
19	X <sup>3</sup>	Nut	A4/ASTM A194 Grade 8M	ASTM A194 Grade 2HM
20	2	Key	A4	

<sup>1</sup> Material combinations other than those specified are available to order. Consult your Flowserve NAF valve representative.

<sup>2</sup> Recommended spare parts  
<sup>3</sup> Quantity depends on the size.

<sup>4</sup> CF8M = ASTM A351 Grade CF8M  
<sup>5</sup> 1.4408 = EN 10213-4 1.4408  
<sup>6</sup> WCB = ASTM A216 Grade WCB

# Seats

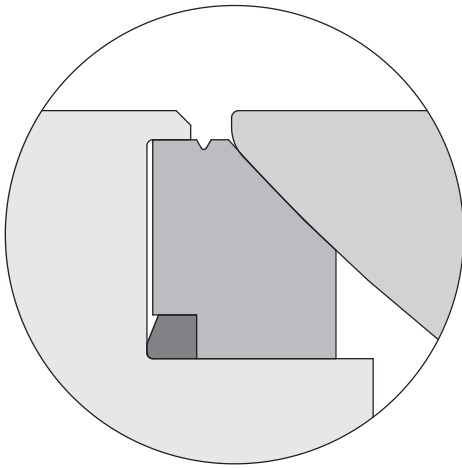

**Metal seat (standard)**

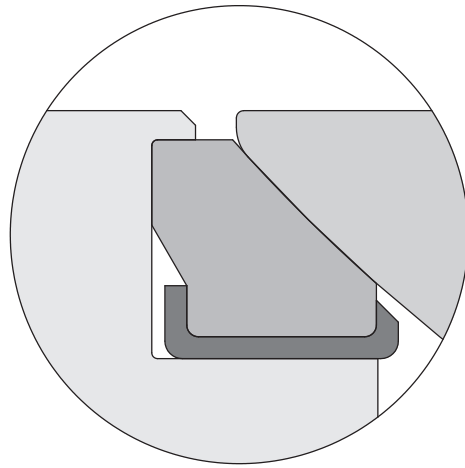

**Soft seat (standard)**

## OPTIONAL SEAT DESIGNS

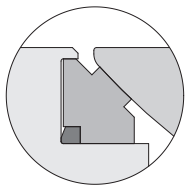

### SCRAPER SEAT

Seat ring with scraper edge.

Option: S (see page 15, section 11)

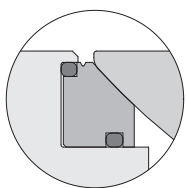

### SEALED SEAT

Seat rings with two O-rings to prevent media penetrating behind seat ring.

Used with media that crystallize.  
(For temperature limitations, please see code 8 in the product code.)

Option: T (see page 15, section 11)

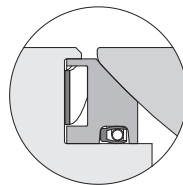

### SPRING-LOADED SEAT

If the differential pressure is low (below 0.5 bar) and a specified tightness must be maintained, O-rings or springs must be fitted behind the seat rings.

Option (see page 15, section 11):

E For temperature limitations, please see code 8 in the product code.

W Wave spring max; 250°C (482°F)

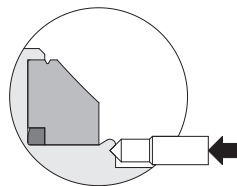

### LOCKED SEAT RINGS

All valves are prepared for locking of the seat rings in the form of peening-over.

Option: L (see page 15, section 11)

# Working pressures and temperatures

## MAXIMUM WORKING PRESSURE PN RATED VALVES

Stainless steel body (CF8M)

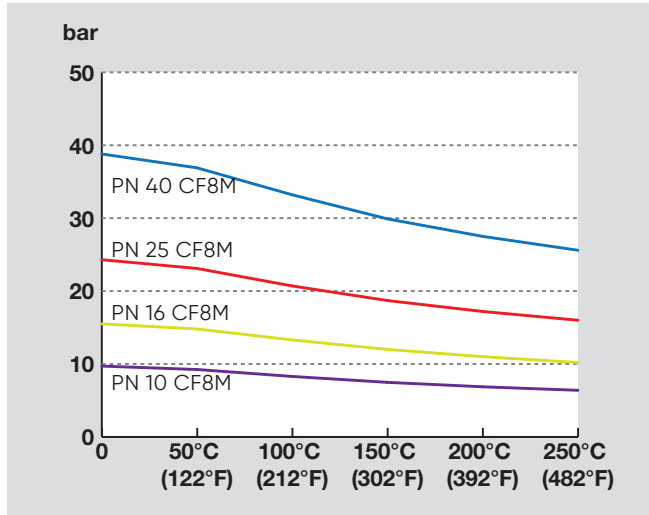

Carbon steel body (WCB)

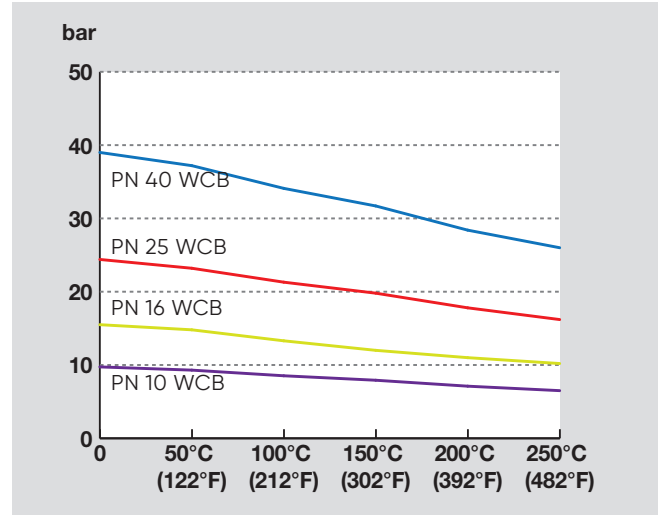

## MAXIMUM WORKING PRESSURE ASME RATED VALVES

Stainless steel body (CF8M)

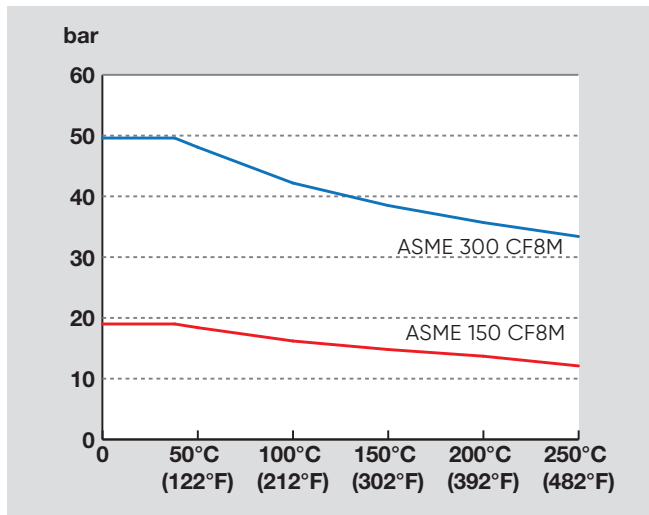

Carbon steel body (WCB)

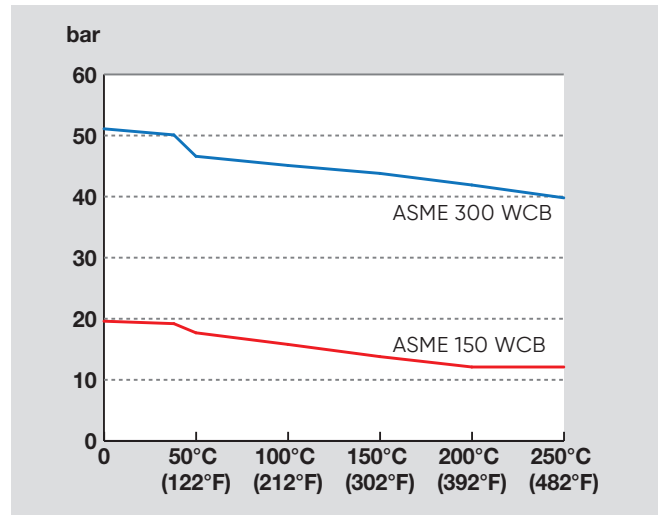

# Differential pressures and temperatures

## MAXIMUM DIFFERENTIAL PRESSURE ALLOY 6 SEAT

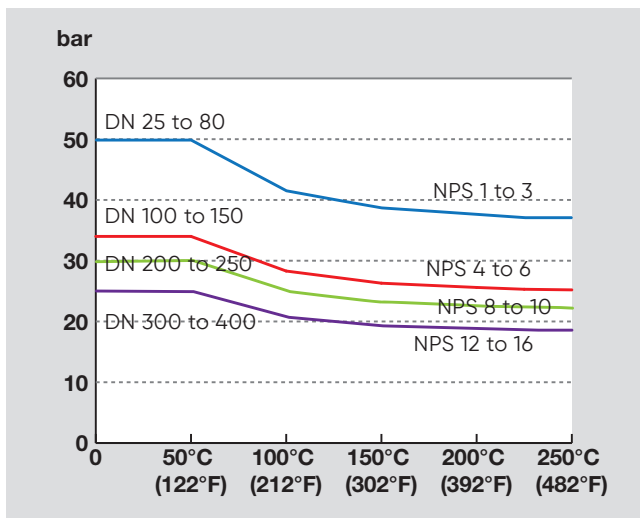

Please note that the maximum allowed differential pressure can be further reduced if the maximum allowed working pressure, based on body material and pressure class of the valve, is lower than the maximum allowed differential pressure.

## MAXIMUM DIFFERENTIAL PRESSURE R-PTFE SEAT

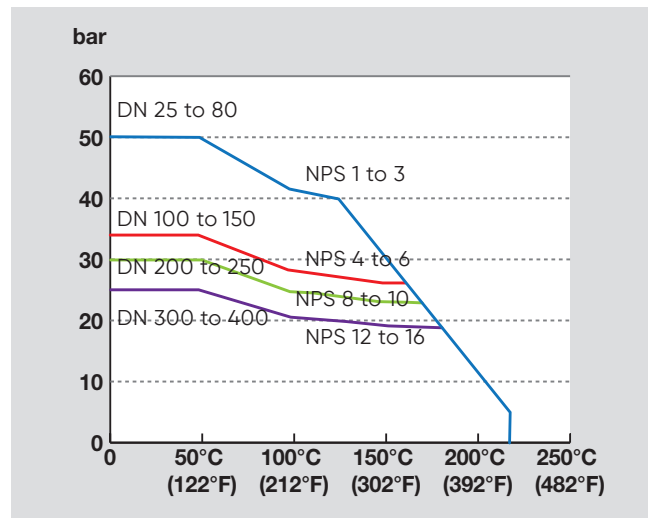

Soft R-PTFE seat ratings are based on differential pressure with the ball in the fully closed position and refer only to the seats. The maximum allowed differential pressure can be further reduced if the maximum allowed working pressure, based on body material and pressure class of the valve, is lower than the maximum allowed differential pressure.

# Operating torques and flow capacities

**TABLE 3: OPERATING TORQUES BY DIFFERENTIAL PRESSURE AND SEAT RING MATERIAL<sup>1</sup>**

Size		Operating torque, Nm																	
DN	NPS	ΔP = 5 bar <sup>(2)</sup>		ΔP = 10 bar		ΔP = 16 bar		ΔP = 20 bar		ΔP = 25 bar		ΔP = 30 bar		ΔP = 35 bar		ΔP = 40 bar		ΔP = 50 bar	
		ring material																	
		PTFE	Alloy 6	PTFE	Alloy 6	PTFE	Alloy 6	PTFE	Alloy 6	PTFE	Alloy 6	PTFE	Alloy 6	PTFE	Alloy 6	PTFE	Alloy 6	PTFE	Alloy 6
25	1	12	15	15	20	19	26	22	30	25	35	28	40	32	45	35	50	41	60
40	1.5	16	20	22	28	29	37	34	43	40	50	46	58	52	65	58	73	70	88
50	2	20	25	30	36	42	50	50	59	60	70	70	81	80	93	90	104	110	126
65	2.5	30	34	57	57	74	85	90	104	110	127	130	151	150	174	170	198	210	245
80	3	55	65	91	109	135	161	164	196	200	240	236	284	273	328	309	371	381	459
100	4	95	115	159	199	235	299	286	366	350	450	414	534	465 <sup>3</sup>	601 <sup>3</sup>	-	-	-	-
125	5	160	210	290	370	446	562	550	690	680	850	810	1,010	940 <sup>3</sup>	1,170 <sup>3</sup>	-	-	-	-
150	6	300	350	500	613	740	928	900	1,138	1,100	1,400	1,300	1,663	1,460 <sup>3</sup>	1,873 <sup>3</sup>	-	-	-	-
200	8	750	930	1,288	1,573	1,933	2,344	2,363	2,858	2,900	3,500	3,438	4,143	-	-	-	-	-	-
250	10	1,500	1,750	2,425	2,938	3,535	4,363	4,275	5,313	5,200	6,500	6,125	7,688	-	-	-	-	-	-
300	12	2,400	3,200	4,050	5,150	6,030	7,490	7,350	9,050	9,000	11,000	-	-	-	-	-	-	-	-
350	14	3,800	4,500	6,475	7,875	9,685	11,925	11,825	14,625	14,500	18,000	-	-	-	-	-	-	-	-
400	16	5,500	7,000	9,625	11,750	14,575	17,450	17,875	21,250	22,000	26,000	-	-	-	-	-	-	-	-

<sup>1</sup> The specified torques in this table are for clean media. When using Alloy 6 seat rings in steam applications, increase the required torque by a factor of 1.5.

If the media is slurry or contains solids, etc., consult Flowserve.

<sup>2</sup> The minimum design differential pressure for selecting the actuator is 5 bar.

<sup>3</sup> Torques given at maximum allowable differential pressure of 34 bar.

**TABLE 4: FLOW CAPACITIES AND CHARACTERISTICS<sup>1</sup>**

Size		Cv <sup>2</sup> at an opening angle of																Z-trim option at 90° opening angle
DN	NPS	15°	20°	25°	30°	35°	40°	45°	50°	55°	60°	65°	70°	75°	80°	85°	90°	
25	1	0	1	2	2	3	4	5	7	9	12	17	24	34	47	61	72	-
40	1.5	0	2	3	5	7	10	14	19	25	33	44	60	86	123	165	191	-
50	2	1	4	5	6	8	14	22	31	39	49	64	89	132	192	255	284	161
65	2.5	1	6	12	14	21	30	41	53	79	92	127	163	242	333	506	575	273
80	3	2	7	16	21	33	49	63	77	101	138	188	247	338	506	768	874	498
100	4	3	11	23	31	55	79	98	123	165	225	295	380	522	800	1,234	1,489	739
125	5	8	18	30	54	80	111	147	194	253	330	436	581	805	1,199	2,025	2,424	1,146
150	6	9	39	63	90	134	182	238	310	348	526	694	933	1,286	1,842	2,509	4,517	1,886
200	8	16	44	84	134	197	270	368	476	628	832	1,082	1,461	2,483	3,311	4,867	9,198	3,246
250	10	70	121	196	277	351	517	676	879	1,150	1,486	1,683	2,569	3,604	5,219	9,259	14,028	6,094
300	12	31	132	245	417	552	714	934	1,196	1,504	1,909	2,491	3,343	5,701	8,567	13,646	23,333	8,620
350	14	120	145	348	536	882	999	1,308	1,696	2,160	2,803	3,690	4,870	7,360	10,341	15,963	30,418	10,633
400	16	198	395	593	791	989	1,347	1,778	2,338	2,989	3,797	4,912	6,563	9,707	13,389	22,913	41,942	16,315

<sup>1</sup> For sizes > DN 400 (NPS 16), see technical bulletin for NAF Trunnball DL valve.

<sup>2</sup> Kv = Cv / 1.16



# Dimensions and weights – valve only

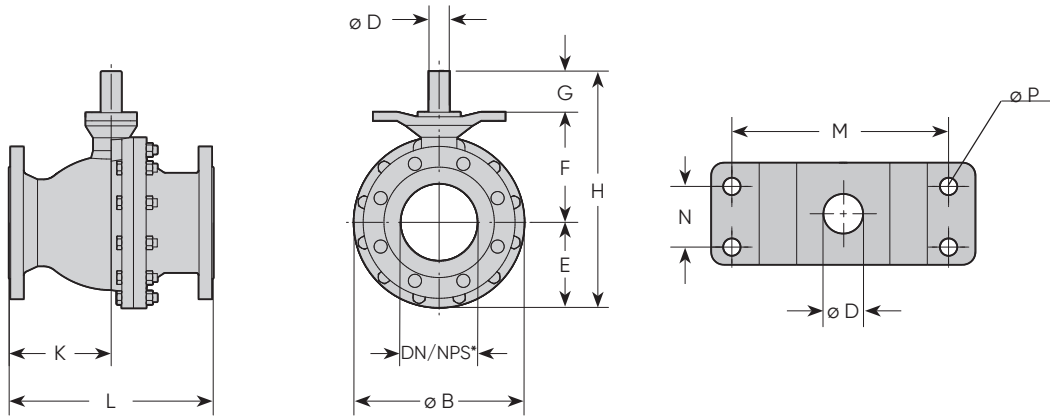

**TABLE 5: COMMON DIMENSIONS – ALL PRESSURE CLASSES**

Size		Dimensions, mm								
DN	NPS	B	D	E	F	G	H	M	N	P
25	1	124	16	62	83	38	183	115	30	11
40	1.5	150	16	75	91	38	204	115	30	11
50	2	165	20	83	106	43	232	115	30	11
65	2.5	190	20	95	115	43	253	115	30	11
80	3	214	25	107	137	50	284	115	30	11
100	4	244	25	122	152	50	324	115	30	11
125	5	310	40	155	203	50	438	214	60	18
150	6	336	40	168	218	80	466	214	60	18
200	8	452	50	226	268	93	587	214	60	18
250	10	528	60	264	321	111	696	214	60	18
300	12	622	70	311	379	131	821	277	115	33
350	14	688	90	344	467	172	983	277	115	33
400	16	767	100	384	518	190	1,092	277	115	33

**TABLE 6: PRESSURE CLASS-RELATED DIMENSIONS AND WEIGHTS**

Size		Dimensions, mm																							
DN	NPS	PN 10			PN 16			PN 25			PN 40			Class 150			Class 300								
		K	L	Weight, kg	K	L	Weight, kg	K	L	Weight, kg	K	L	Weight, kg	K	L	Weight, kg	K	L	Weight, kg						
25	1	Identical to PN 40; choose PN 40									66	165	8	52	127	6	66	165	8						
40	1.5	Identical to PN 40; choose PN 40									95	190	12	60	165	10	95	190	13						
50	2	Identical to PN 40; choose PN 40									108	216	15	74	178	14	108	216	16						
65	2.5	Identical to PN 16; choose PN 16			111	222	19	Identical to PN 40; choose PN 40			111	241	21	Contact Flowserve			Contact Flowserve								
80	3				121	241	26				142	283	31	102	203	27	142	283	33						
100	4				153	305	38				153	305	43	107	229	39	153	305	50						
125	5				178	356	65				178	381	69	Contact Flowserve			Contact Flowserve								
150	6	Identical to PN 16; choose PN 16			197	394	91	Identical to PN 40; choose PN 40			202	403	105	197	394	96	202	403	112						
200	8				229	457	172				229	457	172	251	502	199	251	502	210	229	457	175	210	419	204
250	10				267	533	275				267	533	278	284	568	318	284	568	337	267	533	231	229	457	328
300	12				305	610	412				305	610	420	324	648	429	324	648	525	305	610	430	251	502	501
350	14	343	686	619	343	686	627	381	762	701	381	762	736	343	686	634	381	762	739						
400	16	381	762	838	381	762	848	419	838	944	419	838	1,004	381	762	859	419	838	992						

# Dimensions and weights – valve plus actuation

NAF Duball valves are available with hand levers or pneumatic or electric actuators and accessories.

If other pneumatic or electric actuators are required, consult your Flowserve NAF valve representative.

The maximum differential pressure for selected actuator and valve is based on torque values in Table 3 and is valid for clean media, e.g. water. For steam and other media, please see notes under Table 3.

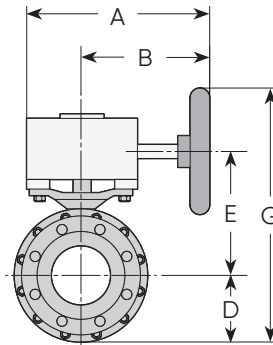
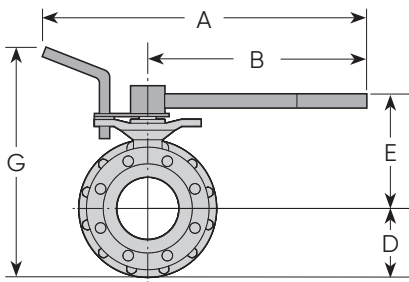

**TABLE 7: NAF DUBALL DL VALVES WITH HAND LEVERS AND WORM GEARS**

Size		Max. Differential Pressure, bar (by seat material)		NAF No.	Dimensions, mm					Weight, kg <sup>1</sup>	
DN	NPS	R-PTFE	Alloy 6		A	B	D	E	G		
<b>Hand lever, as per Fk 70.51</b>											
25	1	25	25	791020-1	500	350	62	121	265	10	
40	1.5	25	25	791020-1	500	350	75	129	286	14	
50	2	25	25	791020-2	500	350	83	144	309	17	
65	2.5	25	25	791020-2	500	350	95	153	330	22	
80	3	15	13	791020-3	500	350	107	185	374	33	
100	4	10	8	791020-3	500	350	107	185	374	45	
<b>Worm gear actuator, as per Fk 70.76<sup>2</sup></b>											
25	1	50	50	791051-11016	249	174	62	117	279	12	
40	1.5	50	50	791051-11016	249	174	75	125	300	16	
50	2	50	50	791051-11020	249	174	83	140	323	19	
65	2.5	50	50	791051-11020	249	174	95	149	344	24	
80	3	50	50	791051-11025	249	174	107	171	378	35	
100	4	30	25	791051-11025	249	174	122	186	408	47	
100	4	50	50	791051-21025	328	243	122	195	467	51	
125	5	50	50	791051-33040	416	291	155	253	608	78	
150	6	50	50	791051-33040	416	291	168	268	636	121	
200	8	16	12	791051-33050	416	291	226	333	759	226	
200	8	30	30	791051-43050	507	337	226	323	799	242	
250	10	18	14	791051-43060	507	337	264	376	890	369	
250	10	30	25	791051-53060	591	421	264	376	840	375	
250	10	30	30	791051-63060	697	487	264	410	974	404	
300	12	17	12	791051-55070	591	421	311	459	970	563	
300	12	25	25	791051-65070	697	487	311	468	1,079	592	
350	14	20	16	791051-65090	697	487	344	591	1,235	803	
350	14	25	23	791051-75090	747	537	344	591	1,235	817	
350	14	25	25	791051-85090	848	593	344	552	1,246	928	
400	16	13	10	791051-65100	697	487	384	657	1,341	1,071	
400	16	17	14	791051-75100	747	537	384	657	1,341	1,085	
400	16	25	25	791051-85100	848	593	384	628	1,362	1,196	

<sup>1</sup> Applies to average weight of a PN 40 valve + lever/gear.

<sup>2</sup> Available with locking device. Please contact Flowserve.



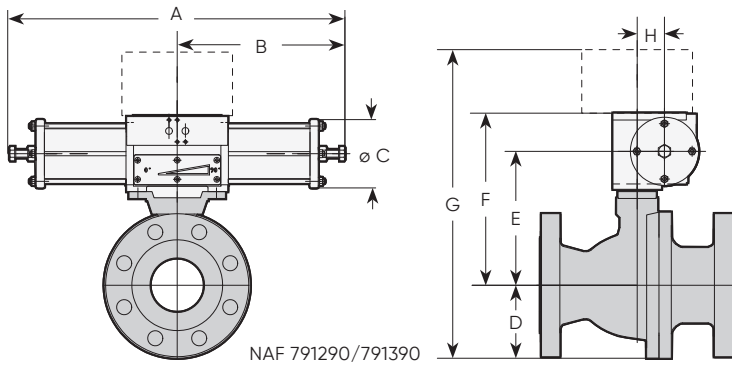

**TABLE 8: NAF DUBALL DL VALVES WITH NAF TURNEX PNEUMATIC ACTUATORS (DOUBLE-ACTING, AS PER FK 74.59)**

Size		Max. Differential Pressure <sup>1</sup> , bar (by supply pressure and seat ring material)						NAF No.	Dimensions, mm								Weight kg <sup>2</sup>
DN	NPS	4 bar		5 bar		6 bar			A	B	C	D	E	F	G <sup>(3)</sup>	H	
		R-PTFE Alloy 6	R-PTFE Alloy 6	R-PTFE Alloy 6	R-PTFE Alloy 6												
25	1	50	50	50	50	50	50	791390-0216	370	185	80	62	134	185	357	31	12
40	1.5	50	45	50	50	50	50	791390-0216	370	185	80	75	142	193	378	31	16
50	2	35	30	45	39	50	48	791390-0220	370	185	80	83	157	208	401	31	19
50	2	50	50	50	50	50	50	791290-1220	490	245	100	83	162	218	411	40	21
65	2.5	19	15	24	20	30	25	791390-0220	370	185	80	95	166	217	422	31	25
65	2.5	29	24	37	31	46	38	791290-1220	490	245	100	95	171	227	432	40	27
65	2.5	50	50	50	50	50	50	791290-2120	700	350	145	95	190	263	468	63	38
80	3	8	6	11	9	14	11	791390-0225	370	185	80	107	188	239	456	31	35
80	3	19	15	24	20	30	24	791290-1225	490	245	100	107	193	249	466	40	37
80	3	41	33	50	43	50	50	791290-2125	700	350	145	107	212	285	502	63	48
80	3	50	50	50	50	50	50	791290-2225	700	350	145	107	212	285	502	63	48
100	4	-	-	5	-	7	5	791390-0225	370	185	80	122	203	254	486	31	47
100	4	10	7	13	9	16	12	791290-1225	490	245	100	122	208	264	496	40	49
100	4	22	17	28	21	35	26	791290-2125	700	350	145	122	227	300	532	63	60
100	4	34	34	34	34	34	34	791290-2225	700	350	145	122	227	300	532	63	60
125	5	9	7	12	9	15	12	791290-2140	700	350	145	155	278	351	616	63	86
125	5	22	17	28	21	34	26	791290-2240	700	350	145	155	278	351	616	63	86
125	5	34	27	34	34	34	34	791290-3140	820	410	200	155	303	395	660	75	98
150	6	5	-	7	5	9	7	791290-2140	700	350	145	168	293	366	644	63	122
150	6	13	10	17	13	21	16	791290-2240	700	350	145	168	293	366	644	63	122
150	6	22	16	28	21	34	25	791290-3140	820	410	200	168	318	410	688	75	134
150	6	34	34	34	34	34	34	791290-3240	820	410	200	168	318	410	688	75	134
200	8	7	5	9	7	11	9	791290-3150	820	410	200	226	368	460	796	75	239
200	8	16	13	20	16	25	20	791290-3250	820	410	200	226	368	460	796	75	239
200	8	30	29	30	30	30	30	791390-4250	1,110	555	260	226	396	499	835	100	255
250	10	8	6	11	8	14	10	791390-4160	1,110	555	260	264	449	552	926	100	382
250	10	19	14	25	19	30	23	791390-4260	1,110	555	260	264	449	552	926	100	382
250	10	30	30	30	30	-	-	791390-4560	1,250	695	395	264	449	552	926	100	447
250	10	30	30	30	30	30	30	791390-5160	1,600	800	395	264	503	651	1,025	150	557
300	12	-	-	5	-	7	-	791390-4170	1,110	555	260	311	543	646	1,067	100	570
300	12	10	7	13	9	16	12	791390-4270	1,110	555	260	311	543	646	1,067	100	570
300	12	20	16	25	21	-	-	791390-4570	1,250	695	395	311	543	646	1,067	100	635
300	12	21	17	25	22	25	25	791390-5170	1,600	800	395	311	561	709	1,130	150	745
300	12	25	25	25	25	25	25	791390-5270	1,600	800	395	311	561	709	1,130	150	745
350	14	12	9	16	12	20	15	791390-5190	1,600	800	395	344	649	797	1,251	150	956
350	14	25	21	25	25	25	25	791390-5290	1,600	800	395	344	649	797	1,251	150	956
400	16	7	5	10	8	12	10	791390-5100	1,600	800	395	384	700	848	1,342	150	1,224
400	16	17	14	22	18	25	22	791390-5200	1,600	800	395	384	700	848	1,342	150	1,224

<sup>1</sup> These differential pressures apply for clean media type water at 20°C (68°F). For other media, contact Flowserve. See also Table 3 notes on page 8.

<sup>2</sup> Applies to average weight of a PN 40 valve + NAF Turnex actuator.

<sup>3</sup> Including all direct mount Flowserve positioners.

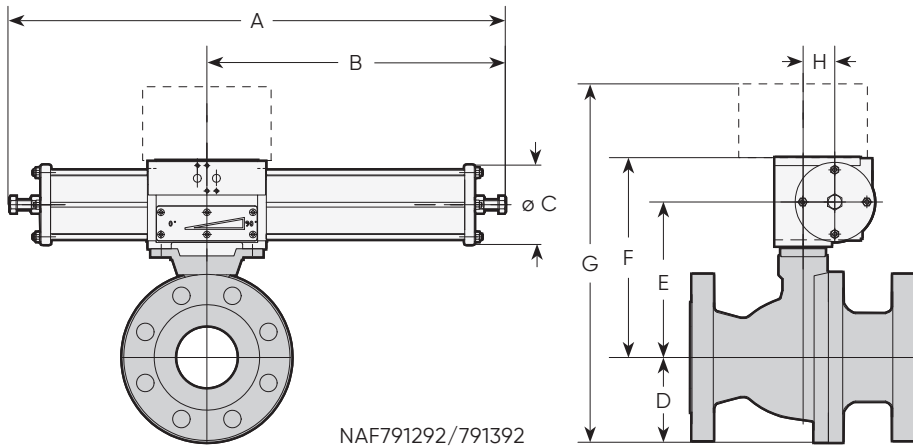

**TABLE 9: NAF DUBALL DL VALVES WITH NAF TURNEX PNEUMATIC ACTUATORS (SINGLE-ACTING, SPRING-TO-CLOSE, AS PER FK 74.59)**

Size		Max. Differential Pressure <sup>1</sup> , bar (by supply pressure and seat ring material)						NAF No.	Dimensions, mm								Weight, kg <sup>2</sup>
DN	NPS	4 bar		5 bar		6 bar			A	B	C	D	E	F	G <sup>(3)</sup>	H	
		R-PTFE Alloy 6	R-PTFE Alloy 6	R-PTFE Alloy 6	R-PTFE Alloy 6	R-PTFE Alloy 6	R-PTFE Alloy 6										
25	1	50	35	50	41	50	41	791392-0216	455	270	80	62	134	185	357	31	13
25	1	50	50	50	50	50	50	791292-1216	635	390	100	62	139	195	367	40	17
40	1.5	29	21	41	26	41	26	791392-0216	455	270	80	75	142	193	378	31	17
40	1.5	50	49	50	50	50	50	791292-1216	635	390	100	75	147	203	388	40	21
50	2	17	13	24	16	24	16	791392-0220	455	270	80	83	157	208	401	31	20
50	2	37	32	50	40	50	40	791292-1220	635	390	100	83	162	218	411	40	24
50	2	50	50	50	50	50	50	791292-2220	890	540	145	83	180	253	446	63	38
65	2.5	8	6	12	10	12	10	791392-0220	455	270	80	95	166	217	422	31	26
65	2.5	13	11	21	17	21	17	791292-1220	635	390	100	95	171	227	432	40	30
65	2.5	50	50	50	50	50	50	791292-2220	890	540	145	95	190	263	468	63	46
80	3	9	7	14	9	14	9	791292-1225	635	390	100	107	193	249	466	40	40
80	3	44	36	50	45	50	45	791292-2225	890	540	145	107	212	285	502	63	54
80	3	50	50	50	50	50	50	791292-3225	1,050	640	200	107	237	329	546	75	74
100	4	-	-	7	-	7	-	791292-1225	635	390	100	122	208	264	496	40	52
100	4	24	18	34	23	34	23	791292-2225	890	540	145	122	227	300	532	63	66
100	4	34	34	34	34	34	34	791292-3225	1,050	640	200	122	252	344	576	75	86
125	5	10	8	16	12	16	12	791292-2240	890	540	145	155	278	351	616	63	94
125	5	34	28	34	34	34	34	791292-3240	1,050	640	200	155	303	395	660	75	112
150	6	6	-	10	5	10	5	791292-2240	890	540	145	168	293	366	644	63	128
150	6	23	17	34	22	34	22	791292-3240	1,050	640	200	168	318	410	688	75	148
150	6	34	34	34	34	34	34	791392-4240	1,520	965	260	168	346	449	727	100	205
200	8	7	5	12	7	12	7	791292-3250	1,050	640	200	226	368	460	796	75	253
200	8	18	14	27	19	28	19	791392-4250	1,520	965	260	226	396	499	835	100	310
200	8	28	19	28	19	28	19	791392-4550	1,665	965	395	226	396	499	835	100	355
250	10	9	6	14	9	14	9	791392-4260	1,520	965	260	264	449	552	926	100	437
250	10	14	9	14	9	14	9	791392-4560	1,665	965	395	264	449	552	926	100	482
250	10	30	30	30	30	30	30	791392-5260	2,210	1,370	395	264	503	651	1,025	150	822
300	12	-	-	7	-	7	-	791392-4270	1,520	965	260	311	543	646	1,067	100	625
300	12	7	-	7	-	7	-	791392-4570	1,665	965	395	311	543	646	1,067	100	670
300	12	22	18	25	24	25	24	791392-5270	2,210	1,370	395	311	561	709	1,130	150	1,010
350	14	13	10	20	13	21	13	791392-5290	2,210	1,370	395	344	649	797	1,251	150	1,221
400	16	8	6	13	8	13	8	791392-5200	2,210	1,370	395	384	700	848	1,342	150	1,489

<sup>1</sup> These differential pressures apply for clean media type water at 20°C (68°F). For other media, contact Flowserve. See also Table 3 notes on page 8.

<sup>2</sup> Applies to average weight of a PN 40 valve + NAF Turnex actuator.

<sup>3</sup> Including all direct mount Flowserve positioners.

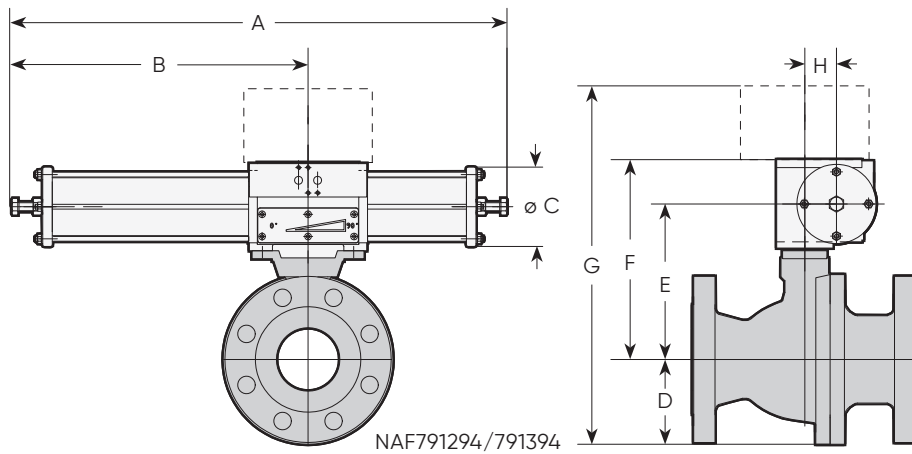

**TABLE 10: NAF DUBALL DL VALVES WITH NAF TURNEX PNEUMATIC ACTUATORS (SINGLE-ACTING, SPRING-TO-OPEN, AS PER FK 74.59)**

Size		Max. Differential Pressure <sup>1</sup> , bar (by supply pressure and seat ring material)						NAF No.	Dimensions, mm								Weight, kg <sup>2</sup>
DN	NPS	4 bar		5 bar		6 bar			A	B	C	D	E	F	G <sup>(3)</sup>	H	
		R-PTFE	Alloy 6	R-PTFE	Alloy 6	R-PTFE	Alloy 6										
25	1	37	18	50	47	50	50	791394-0216	455	270	80	62	134	185	357	31	13
40	1.5	18	10	43	29	43	32	791394-0216	455	270	80	75	142	193	378	31	17
40	1.5	37	22	50	50	50	50	791294-1216	635	390	100	75	147	203	388	40	21
50	2	10	6	25	19	25	21	791394-0220	455	270	80	83	157	208	401	31	20
50	2	21	14	50	40	50	50	791294-1220	635	390	100	83	162	218	411	40	24
65	2.5	5	-	13	10	13	10	791394-0220	455	270	80	95	166	217	422	31	26
65	2.5	8	6	21	17	22	18	791294-1220	635	390	100	95	171	227	432	40	30
65	2.5	50	44	50	50	50	50	791294-2220	890	540	145	95	190	263	468	63	46
80	3	5	-	14	9	14	12	791294-1225	635	390	100	107	193	249	466	40	40
80	3	26	18	50	44	50	50	791294-2225	890	540	145	107	212	285	502	63	54
100	4	-	-	7	-	7	-	791294-1225	635	390	100	122	208	264	496	40	52
100	4	14	8	34	22	34	28	791294-2225	890	540	145	122	227	300	532	63	66
100	4	34	30	34	34	34	34	791294-3225	1,050	640	200	122	252	344	576	75	86
125	5	6	5	15	12	17	13	791294-2240	890	540	145	155	278	351	616	63	94
125	5	24	19	34	34	34	34	791294-3240	1,050	640	200	155	303	395	660	75	112
150	6	-	-	9	5	10	7	791294-2240	890	540	145	168	293	366	644	63	128
150	6	13	8	34	21	34	28	791294-3240	1,050	640	200	168	318	410	688	75	148
150	6	27	17	34	34	34	34	791394-4240	1,520	965	260	168	346	449	727	100	205
150	6	34	34	34	34	34	34	791394-4540	1,665	965	395	168	346	449	727	100	150
200	8	-	-	11	7	12	10	791294-3250	1,050	640	200	226	368	460	796	75	253
200	8	8	5	24	17	29	24	791394-4250	1,520	965	260	226	396	499	835	100	310
200	8	29	24	29	24	29	24	791394-4550	1,665	965	395	226	396	499	835	100	355
250	10	-	-	13	7	15	11	791394-4260	1,520	965	260	264	449	552	926	100	437
250	10	15	11	15	11	15	11	791394-4560	1,665	965	395	264	449	552	926	100	482
250	10	22	14	30	30	30	30	791394-5260	2,210	1,370	395	264	503	651	1,025	150	822
300	12	-	-	6	-	8	5	791394-4270	1,520	965	260	311	543	646	1,067	100	625
300	12	8	5	8	5	8	5	791394-4570	1,665	965	395	311	543	646	1,067	100	670
300	12	11	6	25	21	25	25	791394-5270	2,210	1,370	395	311	561	709	1,130	150	1,010
350	14	6	-	19	12	22	17	791394-5290	2,210	1,370	395	344	649	797	1,251	150	1,221
400	16	-	-	11	7	14	11	791394-5200	2,210	1,370	395	384	700	848	1,342	150	1,489

<sup>1</sup>These differential pressures apply for clean media type water at 20°C (68°F). For other media, contact Flowserve. See also Table 3 notes on page 8.

<sup>2</sup>Applies to average weight of a PN 40 valve + NAF Turnex actuator.

<sup>3</sup>Including all direct mount Flowserve positioners.



# Options

## NAF TURNEX ACTUATOR

A pneumatic NAF Turnex actuator can be directly mounted to the NAF Duball DL valve without any couplings or brackets. Together with the direct mounting capabilities of several of the Flowserve positioners, this provides a high-performance, vibration-resistant and compact valve package suitable for precision control.

Please see data sheet for further information on the NAF Turnex actuator capabilities and all other available accessories.

## VALVE DESIGNS

### DEGREASED

NAF Duball DL valves are available with option D, which needs to be specified for any application where a degreased version is needed. In this version, all components are degreased before assembly and a special grease is used in assembly. (This version is not approved for oxygen service.)

Option: D (see page 15, section 11)

### EXPLOSIVE ATMOSPHERE

When intended for use in an explosive atmosphere, please specify NAF Duball DL valves with option XA. With this option, the valve is certified according to ATEX 94/9/EC  II 2 G/D c.

Option: XA (see page 15, section 11)

### FIRE-SAFE

NAF Duball DL valves are available in fire-safe versions tested according to API 607, 6<sup>th</sup> edition (soft seated versions) and ISO 10497:2010 (soft and metal seated versions). For a list of approved versions, please contact your Flowserve NAF valve representative.

Option: Z (see page 15, section 1, only together with stem seal F in code 9)

### HIGH-TEMPERATURE

Two high-temperature versions of the NAF Duball DL valve are available. The standard high-temperature version is suitable for temperatures up to 350°C (662°F). A special high-temperature version that is suitable for temperatures up to 500°C (932°F) may be ordered on request. This version uses special materials for the bushings, stem packing, washers, seals etc. The stem is extended, allowing actuator mounting at high temperatures. For a detailed specification, please contact your Flowserve NAF valve representative.

# Product code

Example:

**Code**    88   8    4    K    F - 0006 - BAB   A    E    A - L  
                   1    2    3    4    5    6    7    8    9    10   11

## 1. Valve type

- 88** NAF Duball DL
- Z-88 NAF Duball DL with Z-trim option<sup>1</sup>

## 2. Material<sup>2</sup>

- 6** WCB (~EN 1.0619)
- 8** CF8M (~EN 1.4408)

## 3. Pressure rating

- |          |           |                            |
|----------|-----------|----------------------------|
| <b>2</b> | PN 10     | DN 200 to 400 <sup>3</sup> |
| <b>3</b> | PN 16     | DN 80 to 400               |
| <b>4</b> | Class 150 | NPS 1 to 16                |
| <b>5</b> | PN 25     | DN 200 to 400 <sup>3</sup> |
| <b>6</b> | PN 40     | DN 25 to 400               |
| <b>7</b> | Class 300 | NPS 1 to 16                |

## 4. Stem bearing

- K** R-PTFE, carbon-reinforced

## 5. Body type

- F** Flanged

## 6. Size

PN ratings		Class ratings	
	DN		NPS
<b>0025</b>	25	<b>0001</b>	1
<b>0040</b>	40	<b>01.5</b>	1.5
<b>0050</b>	50	<b>0002</b>	2
<b>0065</b>	65	<b>02.5</b>	2.5
<b>0080</b>	80	<b>0003</b>	3
<b>0100</b>	100	<b>0004</b>	4
<b>0125</b>	125	<b>0005</b>	5
<b>0150</b>	150	<b>0006</b>	6
<b>0200</b>	200	<b>0008</b>	8
<b>0250</b>	250	<b>0010</b>	10
<b>0300</b>	300	<b>0012</b>	12
<b>0350</b>	350	<b>0014</b>	14
<b>0400</b>	400	<b>0016</b>	16

## 7. Seat, ball<sup>2</sup> and ball overlay

	Seat	Ball	Overlay
<b>AAA</b>	R-PTFE, carbon-reinforced	CF8M / 316 (~EN 1.4408)	-
<b>BAB</b>	Alloy 6 overlay/SS	CF8M / 316 (~EN 1.4408)	Hard chrome
<b>BAC</b>	Alloy 6 overlay/SS	CF8M / 316 (~EN 1.4408)	Electroless nickel
<b>BAD</b>	Alloy 6 overlay/SS	CF8M / 316 (~EN 1.4408)	Alloy 6
<b>BBA</b>	Alloy 6 overlay/SS	Solid Alloy 6	-

## 8. Seat seal

- A** R-PTFE, carbon-reinforced, max T=250°C
- B** EPDM O-ring (for options E and T), max T=130°C
- C** FPM O-ring (for options E and T), max T=130°C
- E** PFM O-ring (for options E and T), max T=250°C
- H** H-ELAST (same media resistance as EPDM), max T=250°C

## 9. Stem seal

- E** Spring-loaded R-PTFE V-rings, carbon-reinforced
- F** Spring-loaded graphite + R-PTFE V-rings, carbon-reinforced

## 10. Stem material

- A** Duplex EN 1.4460 (~AISI 329)

## 11. Options<sup>4</sup>

- D** Degreased
- E** Spring-loaded seats, O-rings
- L** Locked seats
- S** Scraper seat
- T** Sealed seat
- W** Spring-loaded seats, wave springs
- XA** ATEX certified
- Z** Fire-safe approved design

Versions marked in bold text are the standard versions with shortest lead time.

<sup>1</sup> Sizes DN 50 to 400, NPS 2 to 16

<sup>2</sup> For material CF8, CF3M, CG3M, CG8M, Duplex EN 1.4470, CW-12MW, 904L, M35-01, CK3MCuN, titanium B367 Grade C2, 904L etc., please contact Flowserve.

<sup>3</sup> Sizes 25 to 50 have the same dimensions in PN 10, PN 16, PN 25 and PN 40. Choose PN 40 for these sizes.

Sizes 65 to 150 have the same dimensions in PN 10 and PN 16. Choose PN 16 for these sizes.

Sizes 65 to 150 have the same dimensions in PN 25 and PN 40. Choose PN 40 for these sizes.

<sup>4</sup> If a combination of several options is specified, please add them to a multi-sign code in alphabetic order.





# ANDRITZ

All data, information, statements, photographs and graphic illustrations in this leaflet are without any obligation and raise no liabilities to or form part of any sales contracts of ANDRITZ AG or any affiliates for equipment and/or systems referred to herein. © ANDRITZ AG 2024. All rights reserved. No part of this copyrighted work may be reproduced, modified or distributed in any form or by any means, or stored in any database or retrieval system, without the prior written permission of ANDRITZ AG or its affiliates. Any such unauthorized use for any purpose is a violation of the relevant copyright laws. ANDRITZ AG, Stattegger Strasse 18, 8045 Graz, Austria. NAF ProCap Capping Valve Technical bulletin EN 1.0/2024.



JOHANNESBURG  
Tel: 011 397 2833

**South Africa:**  
**0861 103 103**

DURBAN  
Tel: 031 579 2593

E-mail: [sales@valve.co.za](mailto:sales@valve.co.za)  
[www.valve.co.za](http://www.valve.co.za)

